



TOOLING SYSTEM

2024

2024



HANWOO TOOL CO.,LTD.

Marketing- & Technology
=416, Sambo-techno,122, Jomaru-ro 385beon-gil,
Wonmi-gu, Bucheon-si,
Gyeonggi-do, Republic of Korea
TEL : +82-32-328-3170 FAX : +82-32-678-3175
경기도 부천시 조마루로385번길 122 (춘의동)
삼보테크노타워 4층 416호
(주)대명툴링시스템
TEL : 032-328-3170 FAX : 032-678-3175
Internet : www.kgroup.co.kr
: <https://k-grouptools.com>



ABOUT US



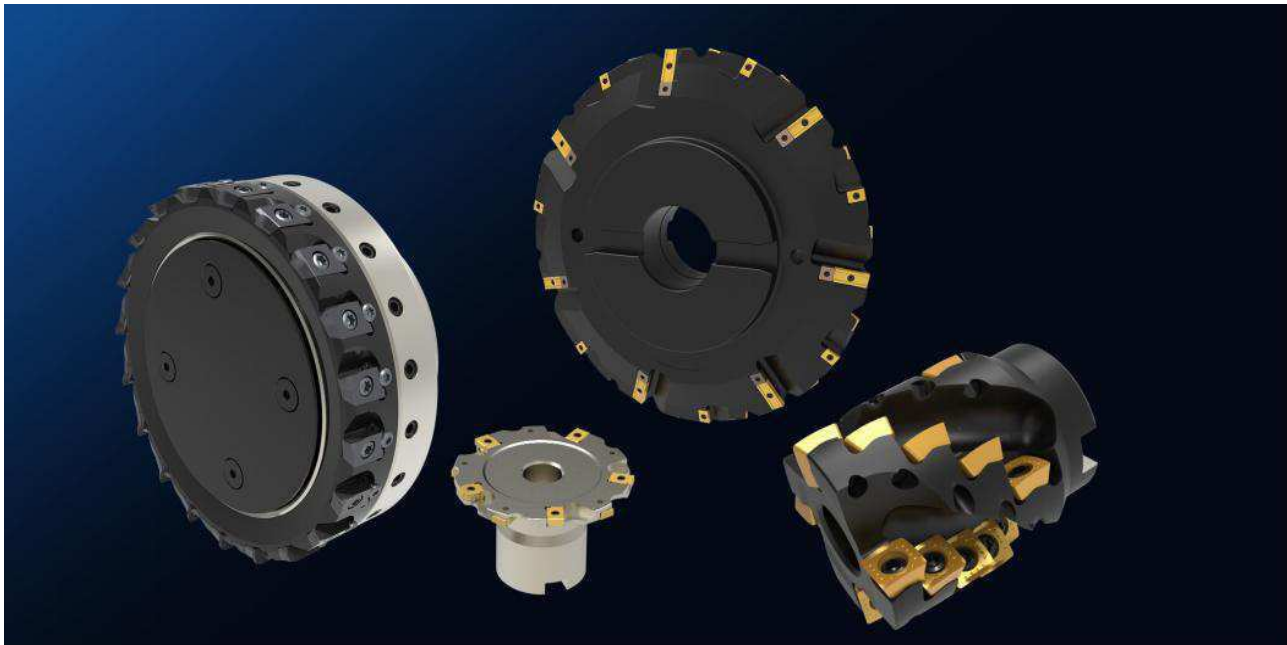

Welcome to Hanwoo !!

Our mission has been to provide market-leading products and services to the worldwide customers in the metalworking industry since the establishment in 2012

Quality focus is our business philosophy.















We have been manufacturing and supplying various kinds of metal cutting tools products, These products offer both productivity and value to our customers.

We will provide innovative and high quality products and services by meeting or exceeding customer requirements for quality, timeliness, and performance. We look forward to seeing you as a part of our growing family of satisfied customers.

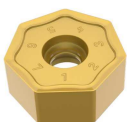
Sincerely, Thank you!

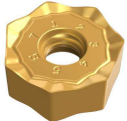













MANULE

ITEM	MODEL/SHAPE	INSERTS	APPLICATION	FEAURES
FACE MILL CUTTER			Kr=42° ap(max)=3mm	<ul style="list-style-type: none"> • Cutter DIA $\phi 50 \sim \phi 125\text{mm}$ • The blade is double-sided 16-edge type, economical good, large rake design of the insert, cutting fast
	 		Kr=43° ap(max)=3mm	<ul style="list-style-type: none"> • Cutter DIA $\phi 63 \sim \phi 160\text{mm}$ • The blade is double-sided 16-edge type, economical good, large rake design of the insert, cutting fast
			Kr=44° ap(max)=6mm	<ul style="list-style-type: none"> • Cutter DIA $\phi 63 \sim \phi 315\text{mm}$ • The blade is double-sided 16-edge type, economical good, large rake design of the insert, cutting fast
			Kr=45° ap(max)=4.0mm	<ul style="list-style-type: none"> • Cutter DIA $\phi 40 \sim \phi 250\text{mm}$ • The blade is double-sided 14-edge type, which is economical • Suitbale for steel, stainless steel, cast iron etc.
			Kr=45° ap(max)=4.0mm	<ul style="list-style-type: none"> • Cutter DIA $\phi 40 \sim \phi 160\text{mm}$ • The blade is double-sided 14-edge type, which is economical • Suitbale for steel, stainless steel, cast iron etc.
	 		Kr=45° ap(max)=5.5mm	<ul style="list-style-type: none"> • Cutter DIA $\phi 63 \sim \phi 250\text{mm}$ • The blade is double-sided 14-edge type, which is economical • Suitbale for steel, stainless steel, cast iron etc.

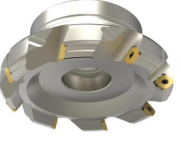
MILLING CUTTER

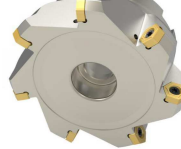

MANULE

ITEM	MODEL/SHAPE	INSERTS	APPLICATION	FEAURES
FACE MILL CUTTER	 new!		Kr=45° ap(max)=5.5mm	<ul style="list-style-type: none"> • Cutter: DIA φ 80~ φ 315mm • The blade is double-sided 14-edge type, which is economical • Suitable for processing steel, stainless steel, cast iron and other materials
			Kr=45° ap(max)=5.5mm	<ul style="list-style-type: none"> • Cutter: DIA φ 50~ φ 315mm • The blade is double-sided and eight-edged type, which is economical, and the blade is designed with a large rake angle for fast cutting. • With the wiper blade to improve surface quality of workpiece.
			Kr=45° ap(max)=7.8mm	<ul style="list-style-type: none"> • Cutter: DIA φ 63~ φ 250mm • The blade is double-sided and eight-edged type, which is economical, and the blade is designed with a large rake angle for fast cutting. • With the wiper blade to improve surface quality.
			Kr=45° ap(max)=6.0mm	<ul style="list-style-type: none"> • Cutter: DIA φ 50~ φ 250mm • Positive large rake angle inserts for faster cutting and wiper inserts to improve the surface quality of the workpiece
			Kr=45° ap(max)=6.1mm	<ul style="list-style-type: none"> • Cutter: DIA φ 63~ φ 250mm • The insert is a double-sided slotting insert with 12 cutting edges, which is economical
			Kr=55° ap(max)=5.0mm	<ul style="list-style-type: none"> • Cutter: DIA φ 50~ φ 160mm • The insert is a double-sided slotting insert with 12 cutting edges, which is economical

MILL CUTTER











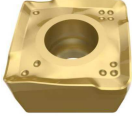

MANULE

ITEM	MODEL/SHAPE	INSERTS	APPLICATION	FEAURES
FACE MILL CUTTER			Kr=75° ap(max)=9.5mm	<ul style="list-style-type: none"> • Cutter: DIA ϕ 50~ϕ 315mm • The blade is double-sided and eight-edged type, which is economical. The large rake angle of the blade is designed for fast cutting. • Design of sparse, dense and super dense teeth
			Kr=88° ap(max)=10.5mm	<ul style="list-style-type: none"> • Cutter: DIA ϕ 50~ϕ 200mm • The blade is double-sided and eight-edged type, which is economical. The large rake angle of the blade is designed for FAST cutting. • Divided into M and ML models.
			Kr=90° ap(max)=10.5mm	<ul style="list-style-type: none"> • Cutter: DIA ϕ 50~ϕ 125mm • The blade is double-sided and eight-edged type, which is economical. The large rake angle of the blade is designed for FAST cutting. • Divided into M and ML models.
			Kr=90° ap(max)=10.5mm	<ul style="list-style-type: none"> • Cutter: DIA ϕ 50~ϕ 160mm • Insert double sided eight edge, very econmical. large positive clearance angle for fast cutting. • Inserts integral wiper design, more suitable for bottom surface finishing • steel, ss steel, cast iron etc.
			Kr=90° ap(max)=9.2mm	<ul style="list-style-type: none"> • Cutter: DIA ϕ 40~ϕ 250mm • Inserts double side 6 edges. • insert large clearance angle, cutting fast • Wiper inserts for better surface processing
			Kr=90° ap(max)=7.5mm	<ul style="list-style-type: none"> • Cutter: DIA ϕ 40~ϕ 160mm • Inserts double side 6 edges. • Wiper inserts for better surface processing

MILL CUTTER





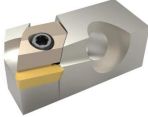







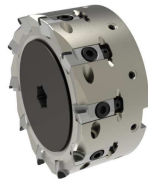
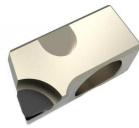



MANULE

ITEM	MODEL/SHAPE	INSERTS	APPLICATION	FEAURES
FACE MILL CUTTER			Kr=90° ap(max)=13mm	<ul style="list-style-type: none"> • Cutter: DIA φ 50~ φ 200mm • 90 degree cutting edge angle, can be used for shoulder milling, ramping milling • Cutting edge length up to 16mm
			Kr=90° ap(max)=10.0mm	<ul style="list-style-type: none"> • Cutter: DIA φ 50~ φ 160mm • Positive 4 edges 0° inserts for fast cutting • AP max cutting depth 5.5-10.0mm • The cutting edge of the blade is in the shape of a large arc.
			Kr=90° ap(max)=16.2mm	<ul style="list-style-type: none"> • Cutter: DIA φ 50~ φ 200mm • 4 righ hand 90° inserts • Design combination of helical cutting edge and large positive rake angle makes cutting easier • P/M/K/S materials with very high metal removal rates
			Kr=90° ap(max)=16.5mm	<ul style="list-style-type: none"> • Cutter: DIA φ 40~ φ 160mm • Flat-mount clamping with 4 cutting edges, large positive rake angle helical cutting edge design, for fast cutting; • For roughing to finishing of steel, stainless steel, superalloy and cast iron.
			Kr=88°	<ul style="list-style-type: none"> • Cutter: DIA φ 80~ φ 250mm • with micro-adjust unit for better adjust, suitable for fine finishing • workpiece excellent surface finish
			Kr=90°	<ul style="list-style-type: none"> • Cutter: DIA φ 125~ φ 500mm • Changable tool holder with various main declination angles and various shapes of blades can be used. • Equipped with a micro-adjust unit, easy to adjust, suitable for fine finishing.

MILL CUTTER















MANULE

ITEM	MODEL/SHAPE	INSERTS	APPLICATION	FEAURES
ALUM CUTTER			Kr=90° ap(max)=4mm	<ul style="list-style-type: none"> • Cutter: DIA ϕ 63~ ϕ 400mm • Aluminum cutter head, dynamic balance treatment, high-speed machining applications Equipped with a fine-tuning mechanism, easy to adjust, suitable for finishing
	 		Kr=90° ap(max)=11mm	<ul style="list-style-type: none"> • Cutter: DIA ϕ 40~ ϕ 63mm • Aluminum cutter head, dynamic balance treatment, high-speed machining applications Equipped with a fine-tuning mechanism, easy to adjust, suitable for finishing
	 		Kr=90° ap(max)=11mm	<ul style="list-style-type: none"> • Cutter: DIA ϕ 80~ ϕ 250mm • Steel cutter ring and aluminum alloy back cutter body, cutter head is dynamically balanced, suitable for high-speed machining applications
HIGH FEED MILL CUTTER			ap(max)=1.5mm	<ul style="list-style-type: none"> • Cutter: DIA ϕ 32~ ϕ 125mm • Inserts are double-sided slotting inserts • Effectively decompose the radial cutting force to realize high feed cutting
			ap(max)=2mm	<ul style="list-style-type: none"> • Cutter: DIA ϕ 50~ ϕ 100mm • Effectively decompose radial cutting force to achieve high feed cutting • Used for machine tools with long overhang and low power, used for roughing molds and removing allowances
	 		ap(max)=2mm	<ul style="list-style-type: none"> • Cutter: DIA ϕ 42~ ϕ 100mm • Effectively decompose radial cutting force to achieve high feed cutting • Used for machine tools with long overhang and low power, used for roughing molds and removing allowances

MILL CUTTER













MANULE

ITEM	MODEL/SHAPE	INSERTS	APPLICATION	FEAURES
HIGH FEED MILL CUTTER			$ap(max)=2.0mm$	<ul style="list-style-type: none"> • Blade turning diameter $\phi 16 \sim \phi 40mm$ • Inserts are double-sided slotting inserts • Effectively decompose the radial cutting force to achieve largefeed cutting • cavity milling face milling
			$ap(max)=2.0mm$	<ul style="list-style-type: none"> • Blade turning diameter $\phi 30 \sim \phi 42mm$ • Inserts are double-sided slotting inserts • Effectively decompose the radial cutting force to achieve largefeed cutting • cavity milling face milling
END MILL SHANK			$Kr=90^\circ$ $ap(max)=13mm$	<ul style="list-style-type: none"> • Blade turning diameter $\phi 25 \sim \phi 40mm$ • 90 degree for clearance angle, for shoulder milling, ramp milling
			$Kr=90^\circ$ $ap(max)=4.0mm$	<ul style="list-style-type: none"> • Blade turning diameter $\phi 20 \sim \phi 32mm$ • Common inserts for face milling and vertical milling
			$Kr=90^\circ$ $ap(max)=4.0mm$	<ul style="list-style-type: none"> • Blade turning diameter $\phi 20 \sim \phi 32mm$ • threaded connection
			$Kr=90^\circ$ $ap(max)=13mm$	<ul style="list-style-type: none"> • Blade turning diameter $\phi 20 \sim \phi 40mm$ • Vertical 4-edged blade • Common inserts for face milling, vertical milling and corn milling

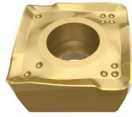
MILL CUTTER

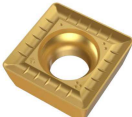

MANULE

ITEM	MODEL/SHAPE	INSERTS	APPLICATION	FEAURES
END MILL SHANK			Kr=90° ap(max)=16.5mm	<ul style="list-style-type: none"> • Blade turning diameter φ20~ φ40mm • Flat-mount clamping with 4 cutting edges, large positive rake angle helical cutting edge design, light cutting; • For roughing to finishing of steel, stainless steel, high temperature alloy and cast iron
			Kr=90° ap(max)=16.5mm	<ul style="list-style-type: none"> • Blade turning diameter φ20~ φ40mm • Flat-mount clamping with 4 cutting edges, large positive rake angle helical cutting edge design, light cutting; • For roughing to finishing of steel, stainless steel, high temperature alloy and cast iron
			Kr=90° ap(max)=10.0mm	<ul style="list-style-type: none"> • SHANK DIA φ40~ φ63mm • Positive 4-flute 90° insert, cutting lightly AP maximum cutting depth 5.5-10.0mm The cutting edge of the blade is in a large arc shape to avoid the occurrence of tool marks in the layered milling of square shoulder
Chamfe ring Mill Holder			Kr=30° Kr=45° Kr=60°	<ul style="list-style-type: none"> • Applicable to all kinds of holes, edge chamfering
			Kr=45°	<ul style="list-style-type: none"> • Blade turning diameter φ23mm • Suitable for small hole chamfering • Machining holes larger than D6 diameter
			Kr=30° Kr=45° Kr=60°	<ul style="list-style-type: none"> • Chamfering knife with long edge • Minimum machining hole diameter: φ5mm • Suitable for all kinds of holes and edge chamfering

MILL CUTTER











MANULE

ITEM	MODEL/SHAPE	INSERTS	APPLICATION	FEAURES
CORN MILL CUTTER			Kr=90° ap(max)=44mm	<ul style="list-style-type: none"> • Corn milling cutter. HOLDER • Blade turning diameter $\phi 32 \sim \phi 40\text{mm}$
			Kr=90°	<ul style="list-style-type: none"> • Blade turning diameter $\phi 25 \sim \phi 40\text{mm}$ • Has four right-hand 90° cutting edges • The design combination of helical cutting edge and large positive rake angle makes cutting easier and faster can be used to process P/M/K/S type material
			Kr=90° ap(max)=76mm	<ul style="list-style-type: none"> • Corn milling cutter. HOLDER • Blade turning diameter $\phi 25 \sim \phi 50\text{mm}$
			Kr=90° ap(max)=88mm	<ul style="list-style-type: none"> • Corn milling cutter. HOLDER • Blade turning diameter $\phi 50 \sim \phi 100\text{mm}$
			Kr=90°	<ul style="list-style-type: none"> • Blade turning diameter $\phi 50 \sim \phi 100\text{mm}$ • The insert has 4 right-hand 90° cutting edges, a combination of helical cutting edges and a large positive rake angle, making cutting easier.
			Kr=90°	<ul style="list-style-type: none"> • Blade turning diameter $\phi 40 \sim \phi 80\text{mm}$ The insert has 4 right-hand 90° cutting edges, a combination of helical cutting edges and a large positive rake angle, making cutting easier.

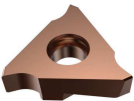
MILL CUTTER

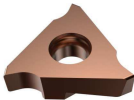
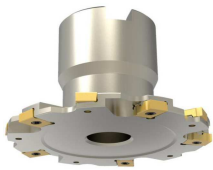
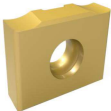





MANULE

ITEM	MODEL/SHAPE	INSERTS	APPLICATION	FEAURES
CORN MILL CUTTER			Kr=90°	<ul style="list-style-type: none"> Stacked corn mill. CUTTER Blade turning diameter $\phi 50 \sim \phi 100\text{mm}$ The interchangeable head structure is economical
Three-sided mill cutter			<ul style="list-style-type: none"> Cut width: 1.1~4.8mm Maximum depth of cut: 5.0mm 	<ul style="list-style-type: none"> Shallow groove milling cutter shank Blade turning diameter $\phi 25 \sim \phi 44\text{mm}$ Wide range of blade widths, suitable for all kinds of shallow grooves and spring grooves
			<ul style="list-style-type: none"> Cut width: 1.1~4.8mm Maximum depth of cut: 5.0mm 	<ul style="list-style-type: none"> Shallow groove milling cutter Cutter DIA $\phi 63 \sim \phi 125\text{mm}$ Wide range of blade widths, suitable for all kinds of shallow grooves and spring grooves
			<ul style="list-style-type: none"> Cut width: 4~14mm Maximum depth of cut: 42mm 	<ul style="list-style-type: none"> Cutter DIA $\phi 80 \sim \phi 160\text{mm}$ Flange type three-sided milling cutter The strength of the vertical blade is good, which makes the tool safer Suitable for all kinds of slot milling
			<ul style="list-style-type: none"> Cut width: 4~14mm Maximum depth of cut: 89mm 	<ul style="list-style-type: none"> Cutter DIA $\phi 63 \sim \phi 250\text{mm}$ Single-piece three-sided milling cutter head The strength of the vertical blade is good, which makes the tool safer Suitable for all kinds of slot milling
			<ul style="list-style-type: none"> Cutting width: 15~25mm 	<ul style="list-style-type: none"> Cutter DIA $\phi 63 \sim \phi 250\text{mm}$ Single-piece three-sided milling cutter head The strength of the vertical blade is good, which makes the tool safer

MILLING CUTTER



MANULE

ITEM	MODEL/SHAPE	INSERTS	APPLICATION	FEAURES
THREAD MILL CUTTER			$Kr=90^\circ$ $ap(max)=40mm$	<ul style="list-style-type: none"> • Single teeth • insert turing dia. $\phi 9.5 \sim \phi 48mm$
Gear Mill cutter	 new!			<ul style="list-style-type: none"> • can design inserts accordingly • Rough milling and fine milling 2-station or 4-station cutter head can be designed according to customer needs

DRILL CUTTER







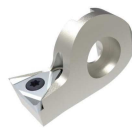

MANULE

ITEM	MODEL/SHAPE	INSERTS	APPLICATIONS	FEATURES
SHALLOW DRILL CUTTER	 C02 . p	 XOMX C01 . p	<ul style="list-style-type: none"> • 2~5 X DIA 	<ul style="list-style-type: none"> • Indexable drill shank • Drilling diameter. $\phi 14 \sim 50$mm • Double inner cooling design
	 C19 . p	 SPMG C01 . p	<ul style="list-style-type: none"> • 2.5~3.5 X DIA 	<ul style="list-style-type: none"> • Large diameter drill • With tool holder, diameter adjustable • Indexable cartridge drill shank • Drilling diameter. $\phi 51 \sim 80$mm • Internal cooling design
	 C23 . p	 XCMT C24 . p	<ul style="list-style-type: none"> • 3 X DIA 	<ul style="list-style-type: none"> • Multifunctional drill • Single tooth design • Suitable for drilling, boring and turning • Drilling diameter. $\phi 12 \sim 32$mm • Internal cooling design
Solid carbide drill	 C26 . p		<ul style="list-style-type: none"> • 3~5 X DIA 	<ul style="list-style-type: none"> • Solid carbide twist drill • Drilling diameter. $\phi 3.3 \sim 16.0$mm
CROWN DIAMOND DRILL	 C56 . p	 CDH C52 . p	<ul style="list-style-type: none"> • 1~10 X DIA 	<ul style="list-style-type: none"> • High-precision drill tip design • Pull-out design after tip installation Strong and sharp drill tip with good chipping performance The overhang diameter can reach 10 times the diameter, with good rigidity

BORING CUTTER

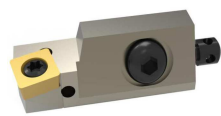

MANULE

ITEM	MODEL/SHAPE	FOCUS	APPLICATIONS	FEATURES
Modular Boring Tool and holder			Kr=92° Kr=95°	<ul style="list-style-type: none"> • Fine boring main body • CK CONNECT • Standard cutter head with internal coolant
			Kr=90° Kr=95°	<ul style="list-style-type: none"> • Fine adjustment tool holder • Fine-tuning precision radius 0.005/div • The maximum radial adjustment is 1mm in diameter, and the axial adjustment is 1mm
		 CC/TC/TP	Kr=90°	<ul style="list-style-type: none"> • Fine boring unit • Two installation methods: angle installation and right angle installation • Adjusting the precision radius 0.01/div
			Kr=90°	<ul style="list-style-type: none"> • CK CONNCTOR • Standard cutter head with internal coolant
			Kr=45° Kr=75° Kr=90°	<ul style="list-style-type: none"> • Ordinary boring holder

BORING CUTTER













MANULE

ITEM	MODEL/SHAPE	FOCUS	APPLICATIONS	FEATURES
BRIDGE BORING TOOL			Kr=90°	<ul style="list-style-type: none"> Standard Steel Bridge Rough Boring Tool (Large Bore), Machining Range $\phi 150 - \phi 850$
			Kr=90°	<ul style="list-style-type: none"> Lightweight aluminum bridge type rough boring tool (large bore), processing range $\phi 150 - \phi 850$
			Kr=90°	<ul style="list-style-type: none"> Standard steel bridge type fine boring tool (large diameter), processing range $\phi 150 - \phi 850$
			Kr=90°	<ul style="list-style-type: none"> Lightweight aluminum bridge type fine boring tool (large bore), processing range $\phi 150 - \phi 850$
SMALL DIA BORING CUTTER				<ul style="list-style-type: none"> Fine boring and fine-tuning mechanism CK6 standard interface Optional adapter sleeve, clamping D8-D16 rod diameter
				<ul style="list-style-type: none"> steel boring bars Processing range D6-D50 Precise boring on the assembly fine-tuning mechanism

BORING CUTTER













MANULE

ITEM	MODEL/SHAPE	FEAUTRES	ITEM	MODEL/SHAPE	FEATURES
SMALL DIA BORING CUTTER		<ul style="list-style-type: none"> • Solid hard anti-vibration boring bar • Adapted to CN fine boring head • Precise boring on the assembly fine-tuning mechanism 	borin g cutte r holde r	BT-CK 	<ul style="list-style-type: none"> • Boring tool holder • Specification BT40 ~BT50 • Interface type CK1 ~CK7
		<ul style="list-style-type: none"> • Solid hard anti-vibration boring bar • Adapted to CN fine boring head • Precise boring on the assembly fine-tuning mechanism 			<ul style="list-style-type: none"> • Boring tool holder • Specification SK40 ~SK50 • Interface type CK1 ~CK7
	<ul style="list-style-type: none"> • Chamfering ring 	HSK A-CK 		<ul style="list-style-type: none"> • Boring tool holder • Specification HSK63 ~HSK100 • Interface type CK1 ~CK7 	
	<ul style="list-style-type: none"> • Super hard solid tungsten carbide boring bar • Interface type CK1 ~CK3 			<ul style="list-style-type: none"> • Equal diameter extension handle • Interface type CK1 ~CK7 • Reducer extension adaptor • Interface type CK1 ~CK6 	
	<ul style="list-style-type: none"> • Straight shank boring bar • Interface type CK1 ~CK6 	D35. P			
				CT 	<ul style="list-style-type: none"> • Bridge boring tool holder • BT/SK/HSK bridge boring holder
			D37. P		

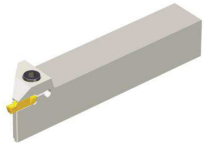
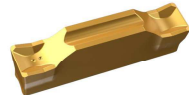
TURNING CUTTER



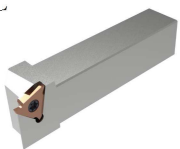
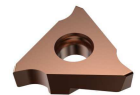

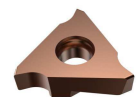







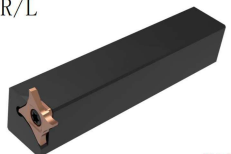

MANULE

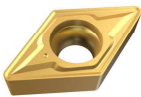
ITEM	MODEL/SHAPE	INSERT	APPLICATION	FEATURES
	TTER/L  E05Page	 E02Page	<ul style="list-style-type: none"> • Cut width: 2~6mm • Maximum depth of cut: 32mm 	<ul style="list-style-type: none"> • External grooving tool holder
	TTFR/L-RN  E07Page	TDGU/X/C  E02Page	<ul style="list-style-type: none"> • Cut width: 3~6mm • Maximum depth of cut: 25mm 	<ul style="list-style-type: none"> • External face grooving holder
	TGFR/L  E09Page	 E02Page	<ul style="list-style-type: none"> • Cut width: 2~4mm • Maximum depth of cut: 8.5mm 	<ul style="list-style-type: none"> • Outer face shallow groove grooving tool holder
	TGIFR/L  E10Page	 E02Page	<ul style="list-style-type: none"> • Cut width: 3~6mm • Maximum depth of cut: 5.5mm 	<ul style="list-style-type: none"> • Face Bore Shallow Groove and Face Turning Toolholders
	TTIR/L  E11Page	 E02Page	<ul style="list-style-type: none"> • Cut width: 2~4mm • Maximum depth of cut: 8.5mm 	<ul style="list-style-type: none"> • Internal grooving tool holder
	CQCR/L  E12Page	 E14Page	<ul style="list-style-type: none"> • Cut width: 1.1~4.8mm 	<ul style="list-style-type: none"> • External Shallow Grooving Toolholder
	SQCR/L  E13Page	 E14Page	<ul style="list-style-type: none"> • Cut width: 2~4mm • Maximum depth of cut: 8.5mm 	<ul style="list-style-type: none"> • internal hole shallow grooving turning tool holder

TURNING CUTTER

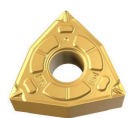

MANULE

ITEM	MODEL/SHAPE	INSERT	APPLICATION	FEATURES
GROOVING CUTTER	4CHR/L  E16Page	 E17Page	<ul style="list-style-type: none"> • Cut width: 2.0~3.5mm • Depth of cut: 4.5-6.5mm 	<ul style="list-style-type: none"> • Shallow groove turning tool holder
	4CHPR/L  E16Page	 E17Page	<ul style="list-style-type: none"> • Cut width: 2.0~3.5mm • Depth of cut: 4.5-6.5mm 	<ul style="list-style-type: none"> • Shallow groove turning tool holder
TURNING INSERTS	 E23Page			<ul style="list-style-type: none"> • Various types of turning blades
EXTERNAL TURNING CUTTER HOLDER	 E38Page			<ul style="list-style-type: none"> • External turning tool holder • Positive blade • S. type screw compression method There are many types of toolholders, suitable for all kinds of turning blades
	 E45Page			<ul style="list-style-type: none"> • external turning tool holder • Negative blade • T-type platen compression method There are many types of toolholders, suitable for all kinds of turning blades
Inner hole turning tool holder	 E53Page			<ul style="list-style-type: none"> • Inner hole turning tool holder • Positive blade • S. type screw compression method There are many types of toolholders
	 E62Page			<ul style="list-style-type: none"> • Inner hole turning tool holder • Negative blade • T-type platen compression method There are many types of toolholders, suitable for all kinds of turning blades

TOOLING SYSTEM











MANULE

ITEM	MODEL/SHAPE	ITEM	MODEL/SHAPE	ITEM	MODEL/SHAPE
Elastic collet holder	BT-ER Elastic collet holder  F02PAGE	FACE MILL CUTTER HOLDER	BT-FMB face mill holder  F13PAGE	Side Mill holder	BT-XS Side Mill Holder  F25PAGE
	SK-ER Elastic collet holder  F04PAGE		SK-FMB face mill holder  F15PAGE		SK-XS Side Mill Holder  F27PAGE
	HSK-ER Elastic collet holder  F06PAGE		HSK-FMB face mill holder  F17PAGE	BT-C. Powerful mill holder  F29PAGE	
HIGH SPEED HOLDER	BT-GSK High-speed HOLDER  F09PAGE	Side mount holder	BT-SLN side mount holder  F19PAGE	Powerful mill holder	SK-C. Powerful mill holder  F30PAGE
	SK-GSK HIGH SPEED HOLDER  F11PAGE		SK-SLN side mount holder  F21PAGE		HSK-C. Powerful holder  F31PAGE
	HSK-GSK HIGH SPEED HOLDER  F12PAGE		HSK-SLN side mount holder  F21PAGE		

TOOLING SYSTEM



MANULE

ITEM	MODEL/SHAPE	ITEM	MODEL/SHAPE	ITEM	MODEL/SHAPE
hydraulic holder	BT-CY hydraulic tool.  F33PAGE	heat shrink shank	BT-RS heat shrink shank  F39PAGE	Micro compensation tool holder	BT-VER Micro tapping body  F46PAGE
	SK-CY hydraulic tool.  F35PAGE		SK-RS heat shrink shank  F42PAGE		C-VER Micro tapping body  F47PAGE
	HSK-CY hydraulic tool.  F37PAGE		HSK-RS heat shrink shank  F43PAGE		HSK-VER Micro tapping body  F48PAGE

TOOLING SYSTEM



MANULE

ITEM	MODEL/SHAPE	ITEM	MODEL/SHAPE	ITEM	MODEL/SHAPE
collet	ER collet  F49PAGE	collet	ODHC OD. COLLECT  F59PAGE	nut	ER NUT  F62PAGE
	ERWater. stop collet  F51PAGE		BT-1982 Rivet  F60PAGE		GSK NUT  F62PAGE
	ETP-ER Rigid Tapping Collet  F54PAGE	RIVET	DIN 69872-SK RIVET  F60PAGE	WRENCH	ER. WRENCH  F63PAGE
	GSK Precision collet  F56PAGE		ISO7388 RIVET  F61PAGE		GSK WRENCH  F63PAGE
	SC強力筒夹  F57PAGE		ISO RIVET  F61PAGE		MLC. WRENCH  F63PAGE
	DHC D MODEL  F58PAGE				

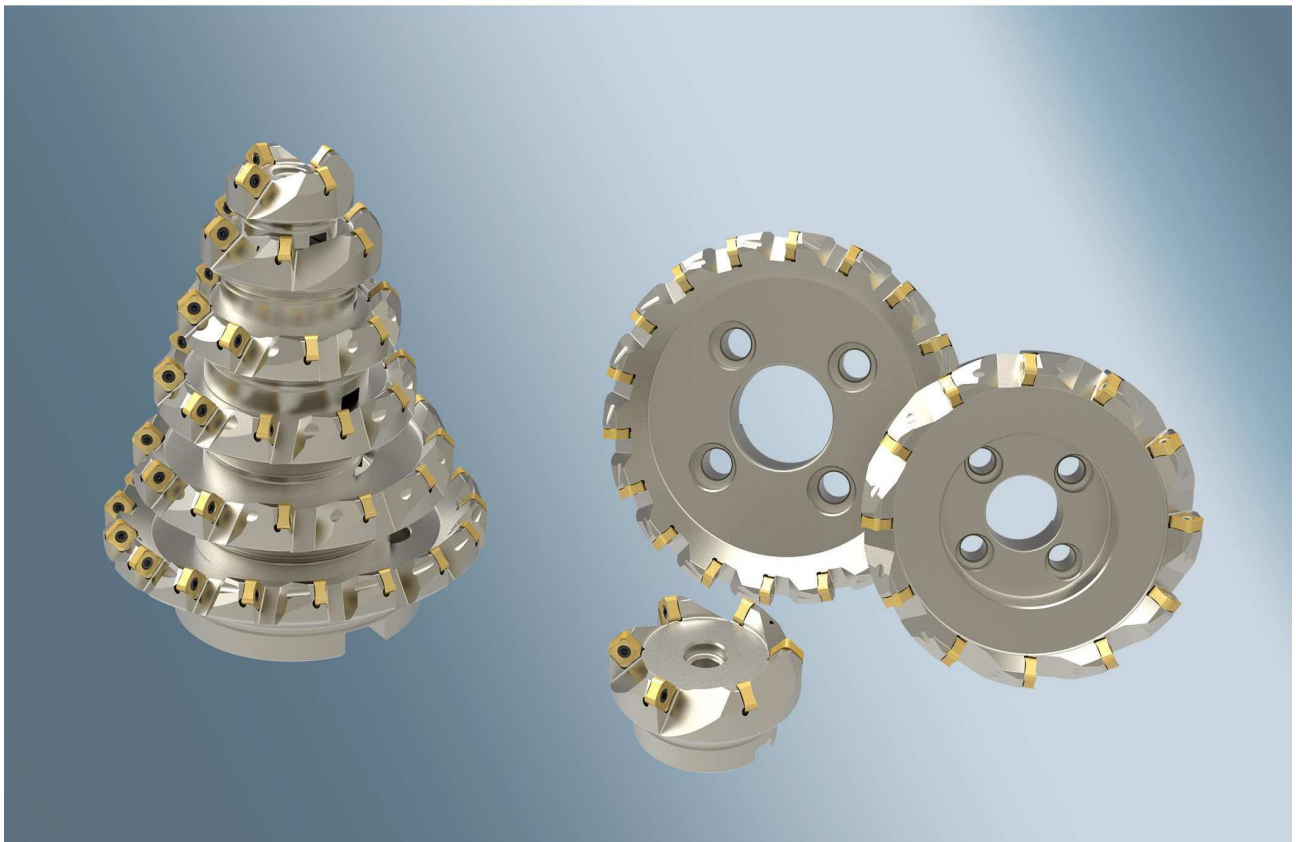
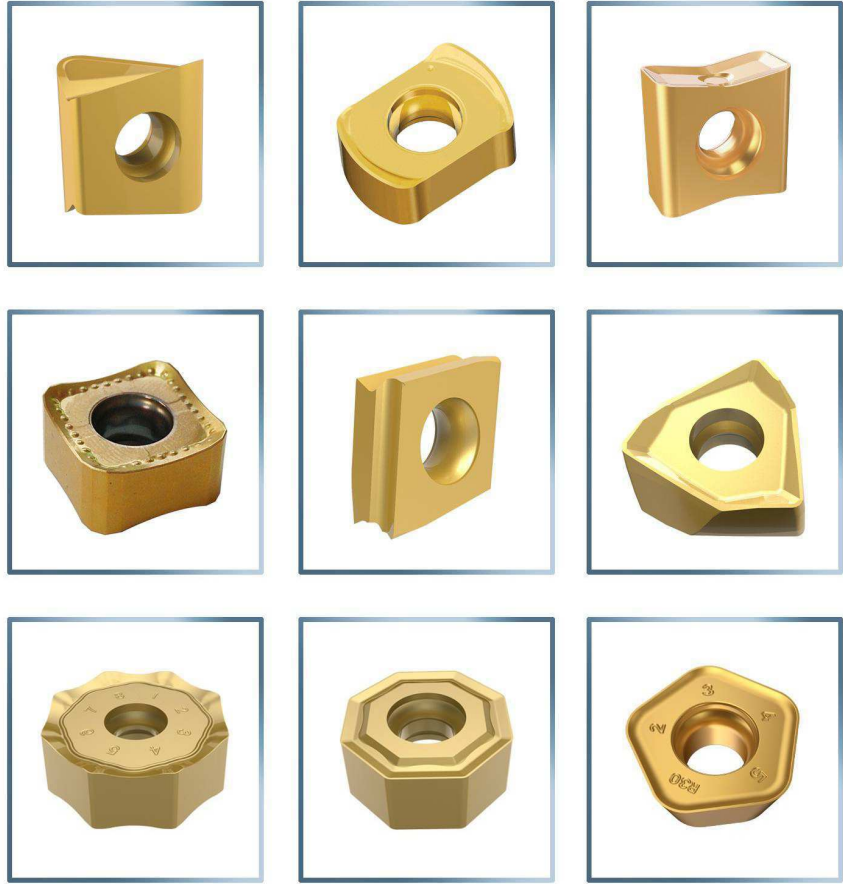

GRADE



CHART

Insert grades and recommended materials						
workpiece	Steel	SS	CAST IRON	nonferrous metal	Alloy	Hard Material
	P	M	K	N	S	H
HW A7				●		
HW8034	●	●	●			●
HW0632	●	●				
HW0622	●	●				
HW1804			●			
HW1814			●			
HW8330		●				
HW8420		●			●	
HW7519	●					

GRADE	WORK PIECE	Directions				
HW A7	N	<ul style="list-style-type: none"> ◇ Uncoated ◇ Mainly suitable for finishing and medium processing of non-ferrous metals 				
HW 8034	<table border="1" style="display: inline-table; vertical-align: middle;"> <tr> <td>P</td> <td>M</td> </tr> <tr> <td>K</td> <td>H</td> </tr> </table>	P	M	K	H	<ul style="list-style-type: none"> ◇ Cermet ◇ Suitable for machining steel, stainless steel, cast iron and hardened steel
P	M					
K	H					
HW 0632 HW 0622	<table border="1" style="display: inline-table; vertical-align: middle;"> <tr> <td>P</td> <td>M</td> </tr> </table>	P	M	<ul style="list-style-type: none"> ◇ With coating ◇ Mainly used for medium machining and rough machining of steel and stainless steel ◇ Nanoscale TiAlN+TiN coating ◇ Has high wear resistance and toughness 		
P	M					
HW 1804 HW 1814	K	<ul style="list-style-type: none"> ◇ With coating ◇ Mainly used for general machining of cast iron 				
HW 8330 HW 8420	<table border="1" style="display: inline-table; vertical-align: middle;"> <tr> <td>P</td> </tr> <tr> <td>M</td> </tr> <tr> <td>S</td> </tr> </table>	P	M	S	<ul style="list-style-type: none"> ◇ With coating ◇ Mainly used for medium processing of stainless steel ◇ Medium machining of heat-resistant alloys 	
P						
M						
S						
HW 7519	<table border="1" style="display: inline-table; vertical-align: middle;"> <tr> <td>P</td> </tr> <tr> <td>K</td> </tr> </table>	P	K	<ul style="list-style-type: none"> ◇ With coating ◇ Mainly used for general machining of steel ◇ Wear-resistant and resistance 		
P						
K						



ON SERIES: HWM 42E-05



FACE MILL CUTTER; $Kr=42^\circ$

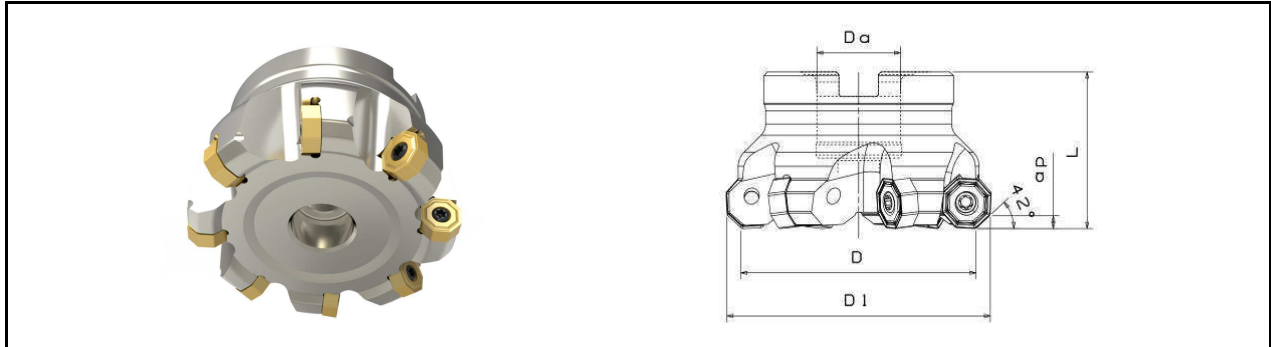

MODEL		DIMENSION					CONNECTOR		INSERT
		D	D1	L	ap	Da			
HWM 42E-A22R50-4	4	50	56.2	40	3	22	A	0.5	ONMU 0504
HWM 42E-A22R50-5	5	50	56.2	40	3	22	A	0.5	
HWM 42E-A22R50-6	6	50	56.2	40	3	22	A	0.5	
HWM 42E-A22R63-6	6	63	69.2	40	3	22	A	0.6	
HWM 42E-A22R63-8	8	63	69.2	40	3	22	A	0.6	
HWM 42E-A27R80-6	6	80	86.2	50	3	27	A	1.1	
HWM 42E-A27R80-8	8	80	86.2	50	3	27	A	1.1	
HWM 42E-A27R80-9	9	80	86.2	50	3	27	A	1.1	
HWM 42E-A32R100-7	7	100	106.2	50	3	32	B	1.8	
HWM 42E-A32R100-9	9	100	106.2	50	3	32	B	1.8	
HWM 42E-A32R100-11	11	100	106.2	50	3	32	B	1.8	
HWM 42E-A40R125-7	7	125	131.2	63	3	40	B	3.0	
HWM 42E-A40R125-9	9	125	131.2	63	3	40	B	3.0	
HWM 42E-A40R125-12	12	125	131.2	63	3	40	B	3.0	

©Standard cutter head without internal coolant; inserts to be ordered separately

INSERT	SHAPE						INTRODUCTION				
							<ul style="list-style-type: none"> • Flat mount INSERT • Double-sided 16 blades • Large front angle design -W geometry inserts are wiper inserts 				
INSERT MODEL	DIMENSION MM						GRADE				SCREW/WRENCH
	D	L	S	ap	R	b	HW0632	HW1814	HW8320	HW A7	
ONMU 050408-M	12.7	4	4.0	3	0.8	/	●	●	●		
ONMU 050408-ML						/	●	●	●	●	
ONMU 050408-MW						1.6	●	●	●		
ONMU 050408-MLW						1.6	●	●	●	●	
ONMU 050408-MK						/	●	●	●		
ONMU 050408-MS						/	●	●	●		

ON SERIES: HWM 43E-07



FACE MILL CUTTER; Kr=43°

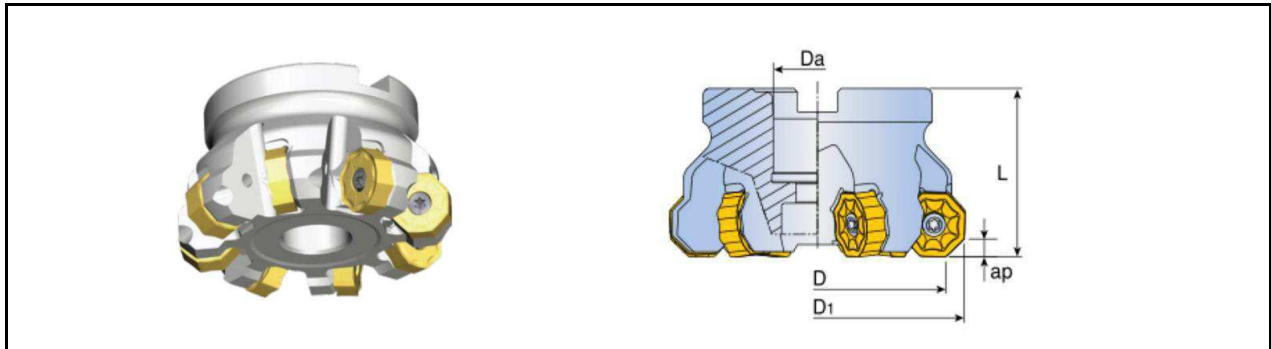

MODEL		DIMENSION					CONNE CTOR	Kg	INSERT
		D	D1	L	ap	Da			
HWM 43E-A22R63-5	5	63	75.2	50	4	22	A	0.8	ONMX 0706
HWM 43E-A27R80-6	6	80	92.2	50	4	27	A	1.2	
HWM 43E-A27R80-7	7	80	92.2	50	4	27	A	1.2	
HWM 43E-A32R100-7	7	100	112.2	60	4	32	B	2.5	
HWM 43E-A32R100-8	8	100	112.2	60	4	32	B	2.5	
HWM 43E-A40R125-8	8	125	137.2	63	4	40	B	3.0	
HWM 43E-A40R125-10	10	125	137.2	63	4	40	B	3.1	
HWM 43E-A40R160-10	10	160	172.2	63	4	40	C	5.2	
HWM 43E-A40R160-12	12	160	172.2	63	4	40	C	5.4	

©Standard cutter head without internal coolant

©INSERT to be ordered separately

INSERT MODEL	EDGE LONG	KR (°)	DIMENSION						GRADE			
			D	L	S	ap	R	b	HW0632	HW1814	HW8330	HW8420
ONMX 070608N-M	07	43	19.05	7.9	7	4	0.8	1.1	●	●	●	●

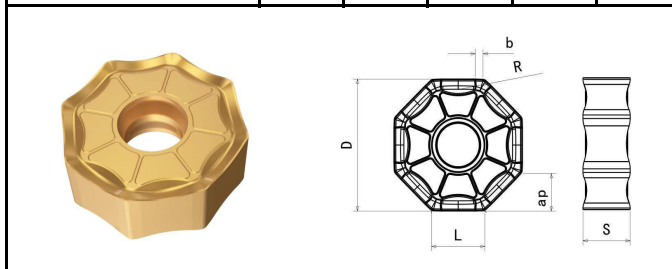

ACCESSORY

MODEL	SCREW	WRENCH
	HWM 43E-07	M5016

ON SERIES: HWM 44E-09



FACE MILL CUTTER; Kr=44°

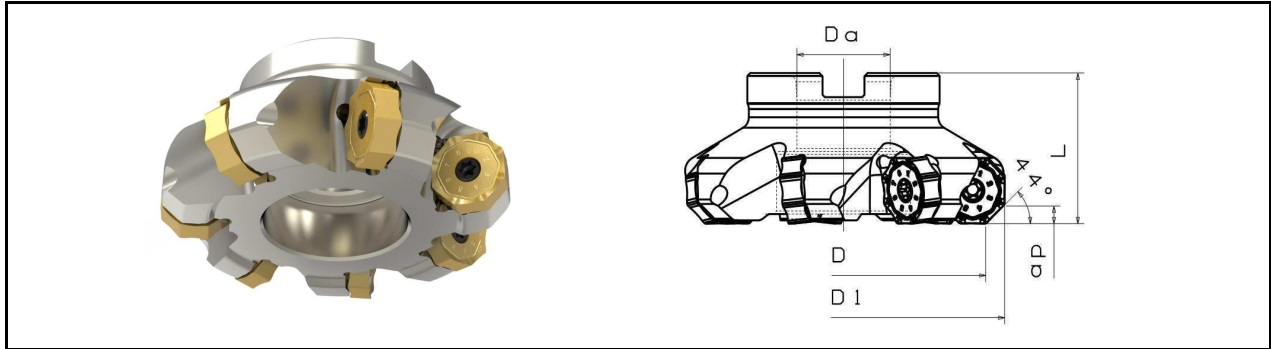

MODEL		DIMENSION					CONNECTOR		INSERT
		D	D1	L	ap	Da			
HWM 44E-A22R63-5	5	63	78	40	5.0	22	A	0.6	ONGU 0905
HWM 44E-A22R63-6	6	63	78	40	5.0	22	A	0.6	
HWM 44E-A27R80-6	6	80	95	50	5.0	27	A	1.1	
HWM 44E-A27R80-7	7	80	95	50	5.0	27	A	1.1	
HWM 44E-A32R100-7	7	100	115	50	5.0	32	B	1.8	
HWM 44E-A32R100-8	8	100	115	50	5.0	32	B	1.8	
HWM 44E-A40R125-8	8	125	140	63	5.0	40	B	3.0	
HWM 44E-A40R125-10	10	125	140	63	5.0	40	B	3.0	
HWM 44E-A40R160-10	10	160	175	63	5.0	40	C	4.4	
HWM 44E-A40R160-12	12	160	175	63	5.0	40	C	4.4	
HWM 44E-A60R200-12	12	200	215	63	5.0	60	C	6.2	
HWM 44E-A60R200-16	16	250	265	63	5.0	60	C	13.5	
HWM 44E-A60R200-20	20	315	330	80	5.0	60	D	27.8	

©Standard cutter head without internal coolant; inserts to be ordered separately

MODEL	EDGE LONG	DIMENSION MM				GRADE							
		L	S	ap	r	HW0632	HW0622	HW1804	HW1814	HW8320	HW8330	HW8420	
ONGU 090506-ML	09	21.85	7.62	5.0	0.6	●				●		●	
ONGU 090506-MLW					1.0	●				●		●	
ONGU 090510-ML					2.0	●					●		●
ONGU 090510-MLW													
ONGU 090520-ML													

- MLW groove inserts are wiper inserts

ACCESSORY

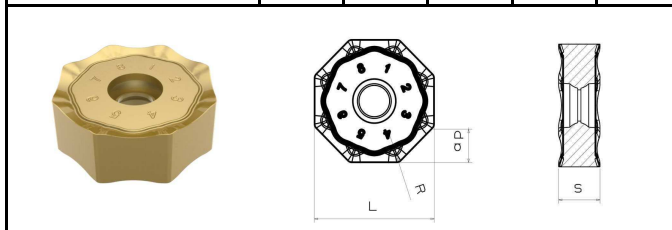

MODEL	SCREW	WRENCH
	HWM 44E-09	M 5016

SN SERIES: HWM 45SN



FACE MILL CUTTER, $Kr=45^\circ$

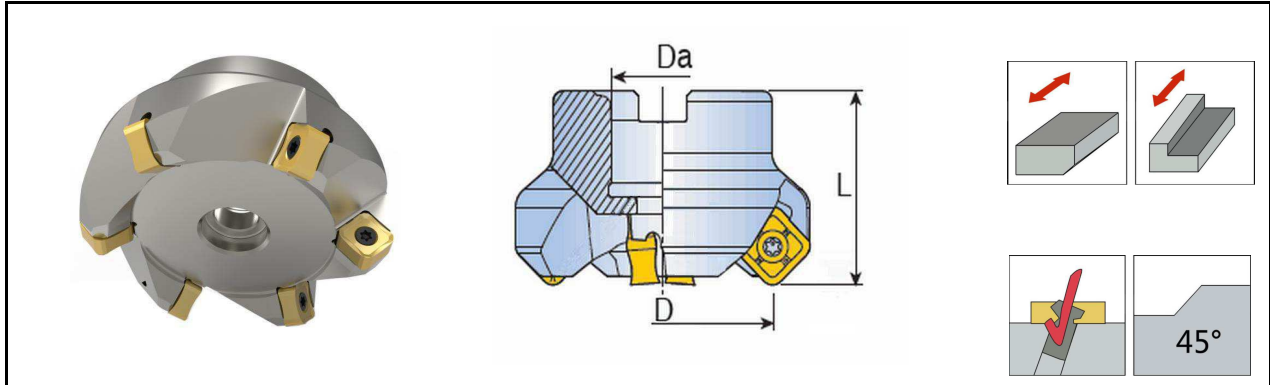

MODEL		DIMENSION MM			MAX DEPTH	CONNECTOR		SUITABLE INSERT
		D	Da	L				
HWM45SN-A22R-50-3	3	50	22	40	6.0	A	0.3	SNGX 1206
HWM45SN-A22R-50-4	4	50	22	40		A	0.3	
HWM45SN-A22R-50-5	5	50	22	40		A	0.3	
HWM45SN-A22R-63-4	4	63	22	40		A	0.5	
HWM45SN-A22R-63-5	5	63	22	40		A	0.5	
HWM45SN-A22R-63-6	6	63	22	40		A	0.5	
HWM45SN-A27R-80-5	5	80	27	50		A	1.2	
HWM45SN-A27R-80-6	6	80	27	50		A	1.2	
HWM45SN-A27R-80-10	10	80	27	50		A	1.2	
HWM45SN-A32R-100-6	6	100	32	50		B	1.8	
HWM45SN-A32R-100-8	8	100	32	50		B	1.8	
HWM45SN-A32R-100-12	12	100	32	50		B	1.8	
HWM45SN-A40R-125-7	7	125	40	63		B	3.0	
HWM45SN-A40R-125-10	10	125	40	63		B	3.0	
HWM45SN-A40R-125-16	16	125	40	63		B	3.0	
HWM45SN-A40R-160-8	8	160	40	63		C	4.6	
HWM45SN-A40R-160-12	12	160	40	63		C	4.6	
HWM45SN-A40R-160-20	20	160	40	63		C	4.6	
HWM45SN-A60R-200-10	10	200	60	63		C	6.5	
HWM45SN-A60R-200-18	18	200	60	63		C	6.5	
HWM45SN-A60R-200-22	22	200	60	63		C	6.5	

©Standard cutter head without internal coolant

©Inserts to be ordered separately

SNGX



INSERTS

SNGX INSERTS

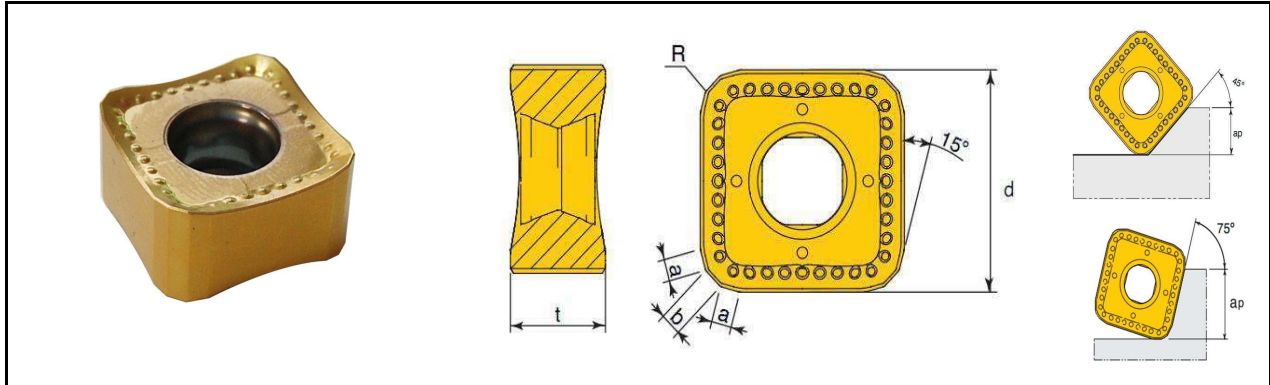

INSERT MODEL	EDGE LONG	DIMENSION					GRADE				
		d	t	a	b	r	HW0632	HW1804	HW8330	HW7519	HW A7
SNGX 1206XTN	12	12.7	6.35	1.25	1.3	0.4	●	●	●	●	
SNGX 1206XTN-ML							●	●	●	●	
SNGX 1206XTN-AL											●

SNGX-W WIPER INSERT

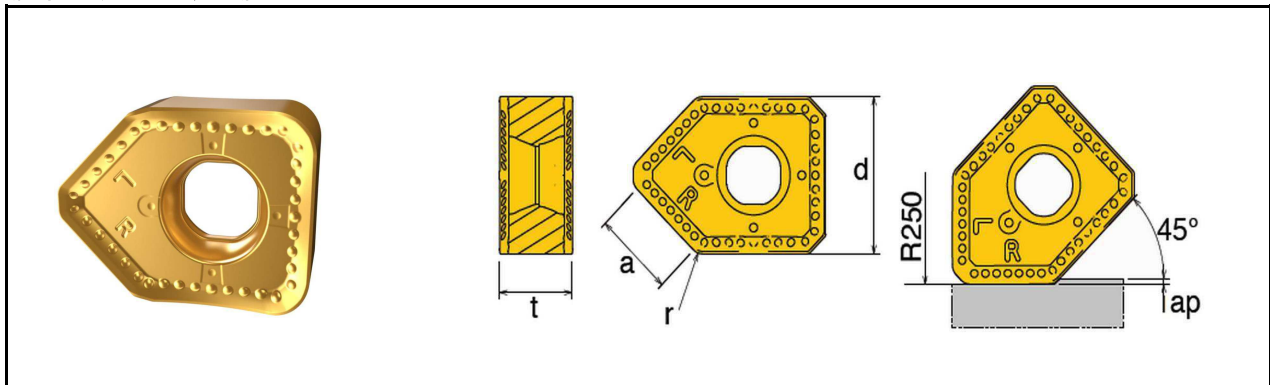

MODEL	DIMENSION				COATING		
	d	t	a	R	HW0632	HW1804	HW7519
SNGX 1206ANSN-W	12.7	6.45	6.9	0.4		●	

SE SERIES: CFM45SE



FACE MILL CUTTER, $Kr=45^\circ$

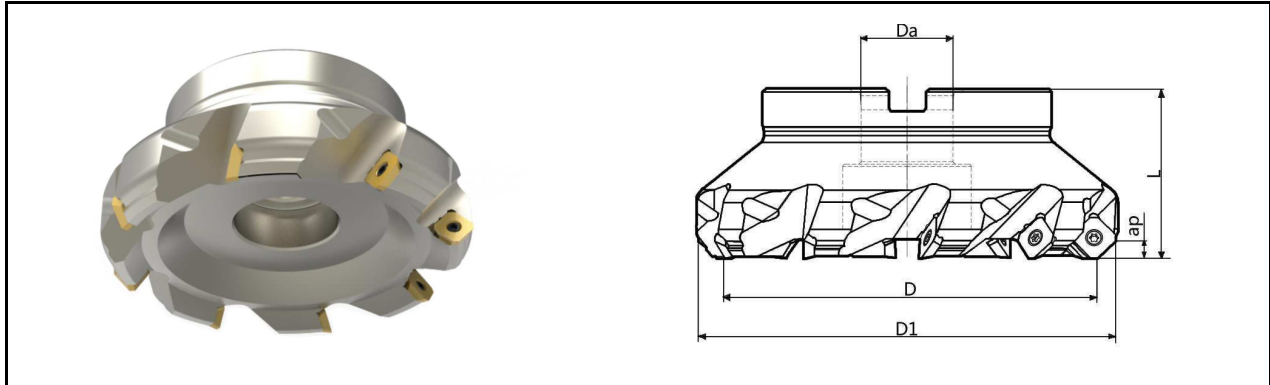

MODEL		DIMENSION MM					CONNE CTOR		FOR INSERT
		D	D1	Da	L	ap			
HWM45SE-A22R-50-4	4	50	62	22	40	6	A	0.3	SEKT. 12T3
HWM45SE-A22R-63-5	5	63	75	22	40	6	A	0.5	
HWM45SE-A27R-80-6	6	80	92	27	50	6	A	1.2	
HWM45SE-A32R-100-7	7	100	112	32	50	6	B	1.2	
HWM45SE-A40R-125-8	8	125	137	40	63	6	B	2.6	
HWM45SE-A40R-160-10	10	160	172	40	63	6	C	4.3	
HWM45SE-A60R-200-12	12	200	212	60	63	6	C	7.6	
HWM45SE-A60R-250-14	14	250	262	60	63	6	C	13.5	

©Standard cutter head without internal coolant

©Blades to be ordered separately

ACCESSORY

MODEL	SCREW	WRENCH
HWM45SE	M 3580	G 15W

SEKT



INSERTS

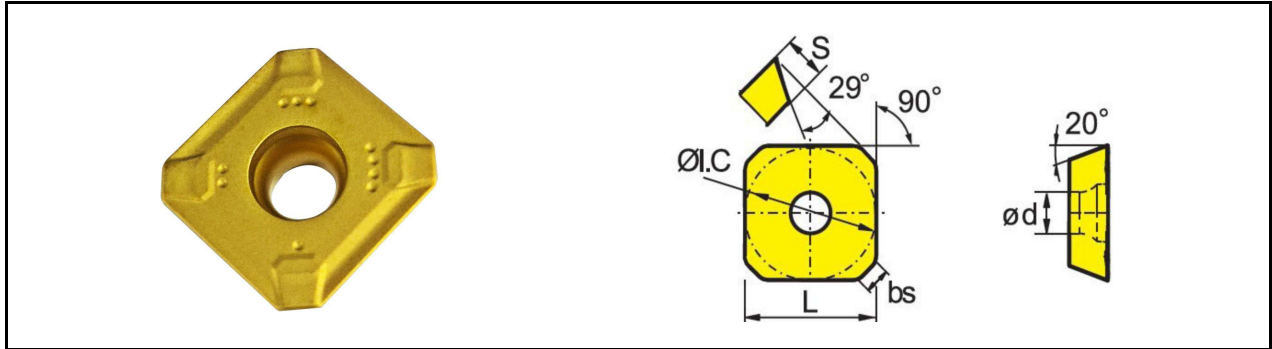

MODEL	EDGE LENGTH	DIMENSION MM						GRADE			
		L	Ø I. C	S	Ø d	bs	R	HW0632	HW1814	HW8420	HW8240
SEKT 12T3M-PM	12	13.4	13.4	3.97	4.1	2.55	—	●	●	●	●



HN SERIES: HWM45HNX



FACE MILL CUTTER, $Kr=45^\circ$

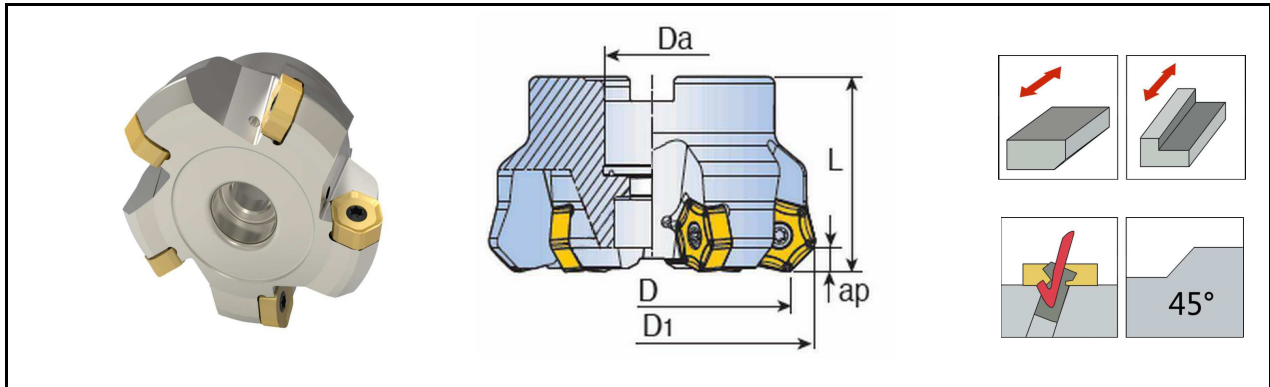

MODEL		DIMENSION (mm)					CONNE CTOR	Kg	FOR INSERT
		D	D1	Da	L	ap			
HWM45HNX-A22R-63-5	5	63	77	22	50	6.1	A	0.8	HNGX 1006
HWM45HNX-A22R-63-6	6	63	77	22	50	6.1	A	0.9	
HWM45HNX-A27R-80-6	6	80	94	27	55	6.1	A	1.6	
HWM45HNX-A27R-80-7	7	80	94	27	55	6.1	A	1.6	
HWM45HNX-A32R-100-7	7	100	114	32	63	6.1	B	2.7	
HWM45HNX-A32R-100-9	9	100	114	32	63	6.1	B	2.8	
HWM45HNX-A40R-125-8	8	125	139	40	63	6.1	B	3.4	
HWM45HNX-A40R-125-10	10	125	139	40	63	6.1	B	3.4	
HWM45HNX-A40R-125-12	12	125	139	40	63	6.1	B	3.4	
HWM45HNX-A40R-160-10	10	160	174	40	63	6.1	C	4.8	
HWM45HNX-A40R-160-12	12	160	174	40	63	6.1	C	4.8	
HWM45HNX-A40R-160-14	14	160	174	40	63	6.1	C	4.9	
HWM45HNX-A60R-200-12	12	200	214	60	63	6.1	C	6.9	
HWM45HNX-A60R-200-16	16	200	214	60	63	6.1	C	7.0	
HWM45HNX-A60R-250-16	16	250	264	60	63	6.1	C	11.8	
HWM45HNX-A60R-250-20	20	250	264	60	63	6.1	C	12.0	

©Standard cutter head with

©Blades to be ordered separately



ACCESSORY



MODEL	SCREW	WRENCH
HNGX45HNX	M 5016	G 20W

HN series: HWM55AHNX

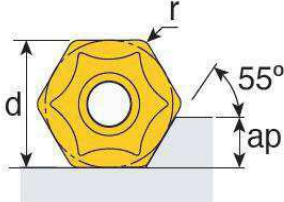

face mill cutter, Kr=55°

insert	shape					introduction					
			Flat. mount blade								
MODEL	EDGE LONG	DIMENSION MM				feed		GRADE			
		d	t	ap	r	(mm/teeth)		HW0632	HW0622	HW1804	HW1814
HNGX 050410N-MM	05	12.7	5.0	5.0	1.0	0.05	0.2	●	●	●	●

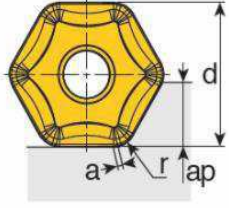
INSERTS	shape					introduction					
			Flat. mount blade								
MODEL	EDGE LONG	DIMENSION MM				Feed		GRADE			
		d	t	ap	r	(mm/TEETH)		HW0632	HW0622	HW1804	HW1814
HNGX 1006ANTN-M	10	19.05	6.35	6.1	1.0	0.1	0.2	●	●	●	●

SNGX



INSERTS

SNGX INSERT

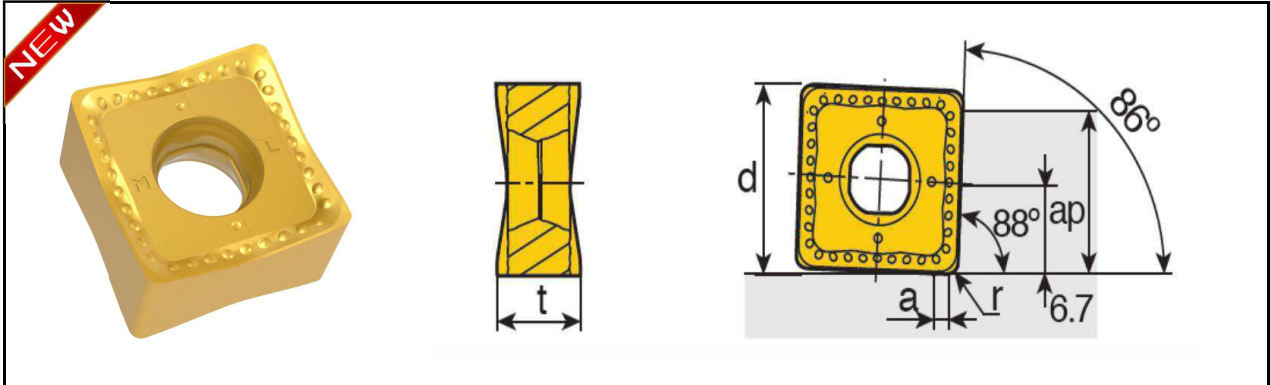

MODEL	EDGE LONG	KR (°)	DIMENSION MM				GRADE				
			d	a	r	ap	HW0632	HW1804	HW8320	HW8330	HW A7
SNGX 1306ZN-M	13	88	13.5	2.2	0.8	2-10	●	●	●		
SNGX 1306ZN-ML	13	88	13.5	2.2	0.8	2-10	●	●	●	●	

©SNGX1306ZN-M/ML grooving cutter can match 88° Kr cutter

SNGX insert

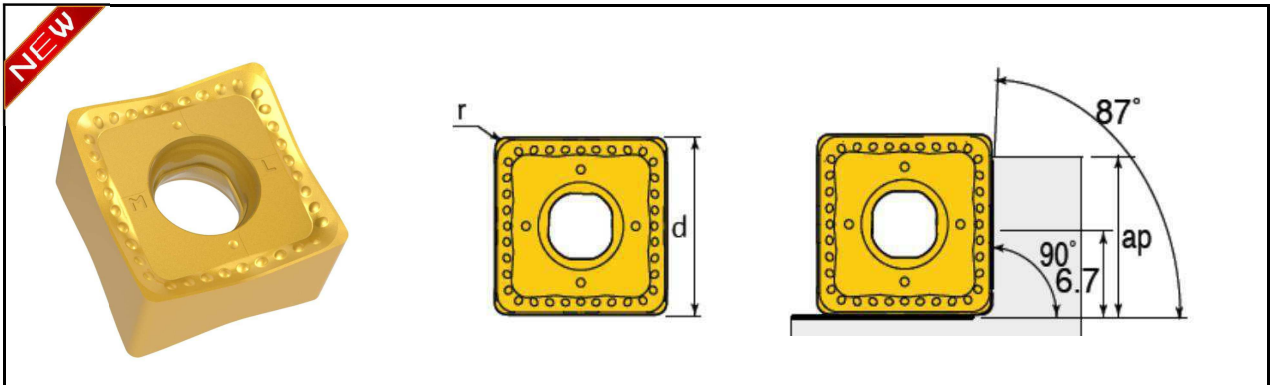

MODEL	EDGE LONG	KR (°)	DIMENSION MM				GRADE				
			d	a	r	ap	HW0632	HW1804	HW8320	HW8520	HW A7
SNGX 130608-M	13	90	13.5	2.2	0.8	2-10	●	●	●		
SNGX 130608-ML						2-10	●	●	●	●	
SNGX 130608-AL						2-10					

©SNGX130608-M/ML/AL grooving inserts can match KR 90° CUTTER

SNHX SERIES: HWM90SN



FACE MILL CUTTER, $Kr=90^\circ$

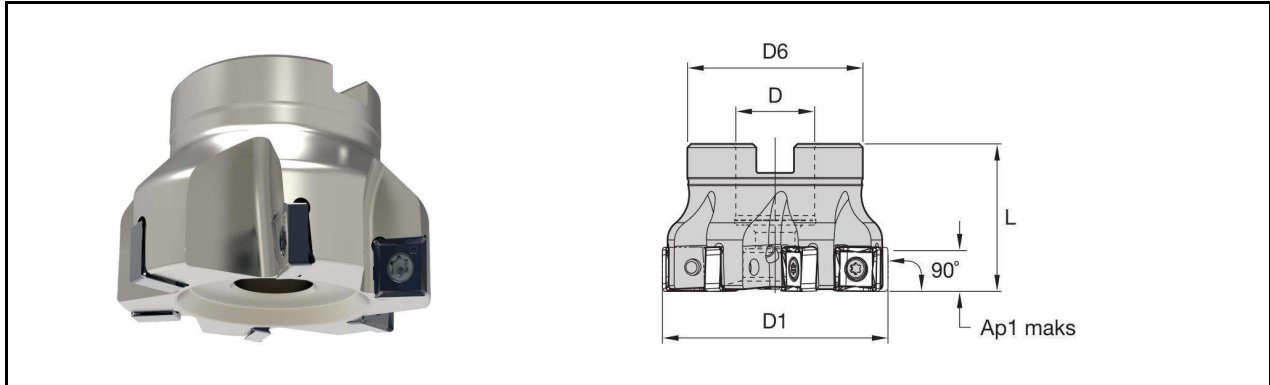

MODEL		DIMENSION MM					CONNE CTOR		SUITABLE INSERT
		D	Da	L	ap	d6			
HWM90SN-A22R-50-4	4	50	22	40	10	47	A	0.32	SNGX 1205
HWM90SN-A22R-50-5	5	50	22	40	10	47	A	0.32	
HWM90SN-A22R-63-5	5	63	22	40	10	47	A	0.48	
HWM90SN-A22R-63-7	7	63	22	40	10	47	A	0.45	
HWM90SN-A27R-80-5	5	80	27	50	10	58	A	0.96	
HWM90SN-A27R-80-7	7	80	27	50	10	58	A	1.03	
HWM90SN-A32R-100-6	6	100	32	50	10	70	B	1.69	
HWM90SN-A32R-100-8	8	100	32	50	10	70	B	1.58	
HWM90SN-A40R-125-7	7	125	40	63	10	85	B	2.79	
HWM90SN-A40R-125-10	10	125	40	63	10	85	B	2.98	
HWM90SN-A40R-160-8	8	160	40	63	10	110	C	4.10	
HWM90SN-A40R-160-12	12	160	40	63	10	110	C	4.15	

©STANDARD. CUTTER WITHOUT. COOLANT, . INSERTS. TO BE ORDERED

INSERTS	SHAPE					introduction				
						Positive large rake angle inserts Blade Integral Wiper Design				
MODEL	DIMENSION					GRADE			SCREW	WRENCH
	L1	D	S	Bs	R	HW0622	HW1814	HW8420		
SNGX 120508-M	12.7	12.7	4.6	1.34	0.8	●	●	●	M 4013-P	G 15W-P

XN SERIES: HWM90XN



FACE MILL CUTTER, $Kr=90^\circ$

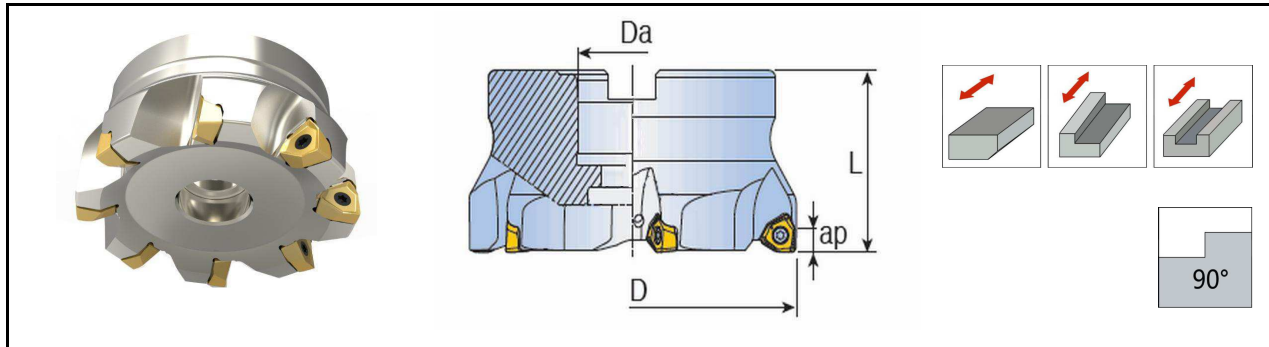

MODEL		DIMENSION)				CONNE CTOR	Kg	SUITABLE INSERTS
		D	Da	L	ap			
HWM90XN-A16R-40-4	4	40	16	40	6.2	A	0.3	XNKU 0604
HWM90XN-A22R-50-4	4	50	22	40	6.2	A	0.4	
HWM90XN-A22R-50-6	6	50	22	40	6.2	A	0.4	
HWM90XN-A22R-63-4	4	63	22	40	6.2	A	0.5	
HWM90XN-A22R-63-6	6	63	22	40	6.2	A	0.5	
HWM90XN-A22R-63-7	7	63	22	40	6.2	A	0.5	
HWM90XN-A27R-80-5	5	80	27	50	6.2	A	1.0	
HWM90XN-A27R-80-7	7	80	27	50	6.2	A	1.0	
HWM90XN-A27R-80-9	9	80	27	50	6.2	A	1.0	
HWM90XN-A32R-100-6	6	100	32	50	6.2	B	1.9	
HWM90XN-A32R-100-8	8	100	32	50	6.2	B	1.9	
HWM90XN-A32R-100-11	11	100	32	50	6.2	B	1.9	
HWM90XN-A40R-125-7	7	125	40	63	6.2	B	3.2	
HWM90XN-A40R-125-11	11	125	40	63	6.2	B	3.2	
HWM90XN-A40R-125-14	14	125	40	63	6.2	B	3.2	

©Standard cutter head without internal coolant; inserts to be ordered

INSERT MODEL	DIMENSION)						GRADE			
	d	t	ap	a	r	FEED (mm/TEETH)	CT5320	CT5420	CT7320	CT7420
XNKU 060408-M	9.26	4.76	6.2	1.96	0.8	0.08-0.15	●	●	●	●
XNKU 090508-M	13.05	6.70	9.2	2.0	0.8	0.10-0.20		●		●
XNKU 090508-ML	13.05	6.70	9.2	2.0	0.8	0.05-0.10		●		●
XNMU 090508R-M	13.05	6.70	9.2	2.0	0.8	0.05-0.10		●		●

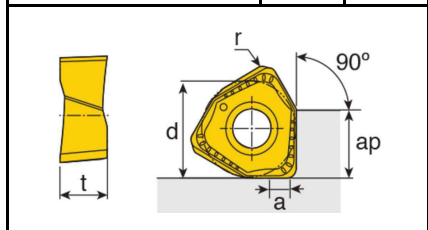

MODEL	SCREW	WRENCH
	HWM90XN-06	M 3080
HWM90XN-09	M 4010	G 15W

WN SERIES: HWM90WN



FACE MILL CUTTER, $Kr=90^\circ$

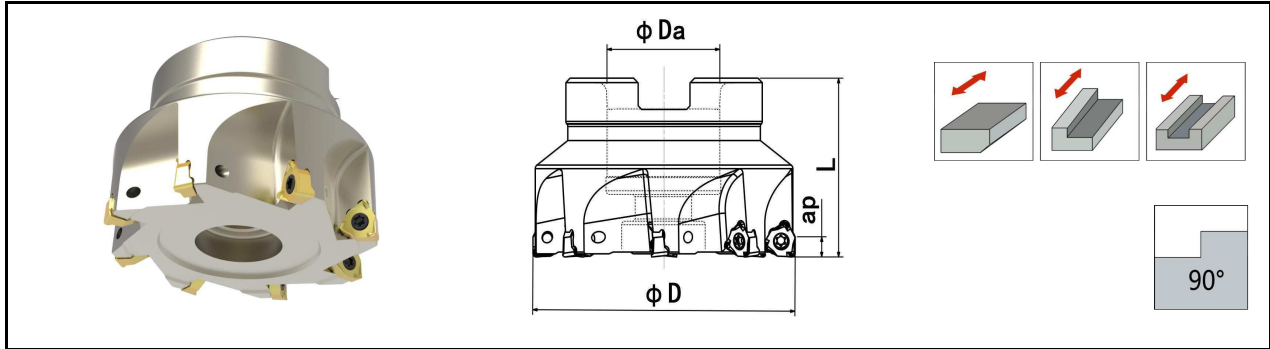

MODEL		DIMENSION)				CONNE CTOR		SUITABLE INSERTS
		D	Da	L	ap			
HWM90WN-A16R-40-6	6	40	16	40	4.0	A	0.2	WNGX 0403
HWM90WN-A16R-40-7	7	40	16	40	4.0	A	0.2	
HWM90WN-A22R-50-8	8	50	22	40	4.0	A	0.4	
HWM90WN-A22R-50-9	9	50	22	40	4.0	A	0.4	
HWM90WN-A22R-63-9	9	63	22	40	4.0	A	0.7	
HWM90WN-A22R-63-10	10	63	22	40	4.0	A	0.7	
HWM90WN-A22R-50-4	4	50	22	40	7.5	A	0.3	WNGX 0806
HWM90WN-A22R-50-5	5	50	22	40	7.5	A	0.3	
HWM90WN-A22R-63-4	4	63	22	40	7.5	A	0.4	
HWM90WN-A22R-63-6	6	63	22	40	7.5	A	0.4	
HWM90WN-A22R-63-7	7	63	22	40	7.5	A	0.4	
HWM90WN-A22R-63-6	6	63	27	40	7.5	A	0.4	
HWM90WN-A22R-63-7	7	63	27	40	7.5	A	0.4	
HWM90WN-A27R-80-5	5	80	27	50	7.5	A	1.0	
HWM90WN-A27R-80-7	7	80	27	50	7.5	A	1.0	
HWM90WN-A27R-80-9	9	80	27	50	7.5	A	1.0	
HWM90WN-A32R-100-100	6	100	32	50	7.5	B	1.5	
HWM90WN-A32R-100-8	8	100	32	50	7.5	B	1.5	
HWM90WN-A32R-100-11	11	100	32	50	7.5	B	1.5	
HWM90WN-A40R-125-7	7	125	40	63	7.5	B	2.8	
HWM90WN-A40R-125-11	11	125	40	63	7.5	B	2.8	
HWM90WN-A40R-125-14	14	125	40	63	7.5	B	2.8	
HWM90WN-A40R-160-12	12	160	40	63	7.5	C	4.8	
HWM90WN-A40R-160-16	16	160	40	63	7.5	C	4.8	

©Standard cutter head without internal coolant; inserts to be ordered separately

WN



INSERTS

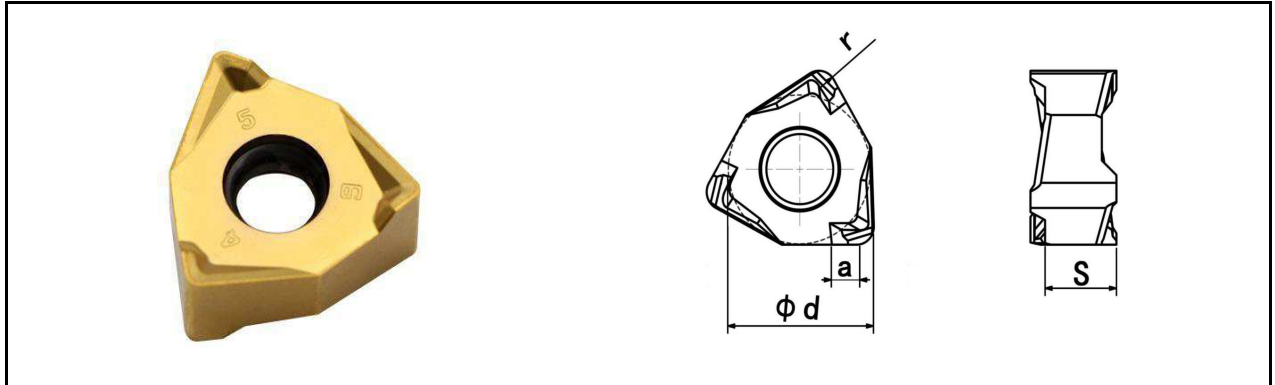

MODEL	EDGE LONG	DIMENSION)				GRADE		COMPATIBLE SCREW/WRENCH
		d	r	S	a	HW0632	HW1814	
WNGX 040308-ML	04	7.64	0.8	3.29	1.1	●	●	M 2565-P/G. 08W-P
WNGX 080608-ML	08	12.48	0.8	6.35	1.2 2.0	●	●	M 4013-P
WNGX 080608-TR	08	12.48	0.8	6.35	1.2~2.0	●		G 15W-P



AP17 SERIES: TFM90AP



FACE MILL CUTTER, $Kr=90^\circ$

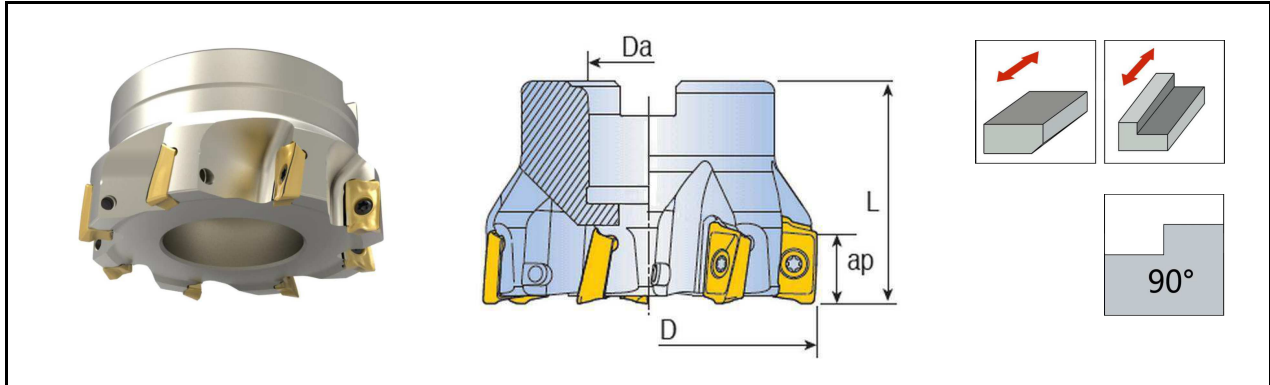

MODEL		DIMENSION				CONNECTOR		SUITABLE INSERT
		D	Da	L	ap			
HWM90AP-A22R-50-3	3	50	22	40	16.1	A	0.4	APKT. 1705
HWM90AP-A22R-50-4	4	50	22	40	16.1	A	0.3	
HWM90AP-A22R-50-5	5	50	22	40	16.1	A	0.4	
HWM90AP-A22R-63-4	4	63	22	40	16.1	A	0.5	
HWM90AP-A22R-63-6	6	63	22	40	16.1	A	0.5	
HWM90AP-A27R-80-4	4	80	27	50	16.1	A	0.8	
HWM90AP-A27R-80-6	6	80	27	50	16.1	A	0.9	
HWM90AP-A27R-80-7	7	80	27	50	16.1	A	0.9	
HWM90AP-A32R-100-6	6	100	32	50	16.1	B	1.3	
HWM90AP-A32R-100-8	8	100	32	50	16.1	B	1.5	
HWM90AP-A40R-125-7	7	125	40	63	16.1	B	2.9	
HWM90AP-A40R-125-8	8	125	40	63	16.1	B	3.0	
HWM90AP-A40R-125-9	9	125	40	63	16.1	B	3.1	
HWM90AP-A40R-160-8	8	160	40	63	16.1	C	4.1	
HWM90AP-A40R-160-10	10	160	40	63	16.1	C	4.2	
HWM90AP-A60R-200-12	12	200	60	63	16.1	C	6.1	

©Standard cutter head without internal coolant, inserts to be ordered separately

©B. TYPE is unequal teeth.

ACCESSORY

MODEL	SCREW	WRENCH
HWM90AP	M 4090	G. 15W

APKT 17



INSERTS

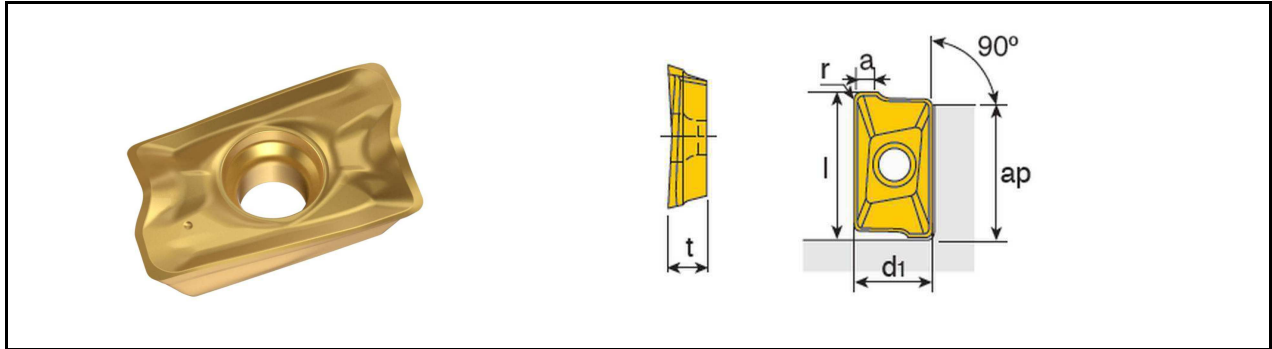

MODEL	EDGE LONG	DIMENSION						GRADE			
		d	ap	L	t	a	r	HW0632	HW1814	HW8320	HW7519
APKT 1705PER-EM	17	10.7	16.1	18.5	5.56	3.0	0.8	●	●		

SD14 SERIES: HWM90SD



FACE MILL CUTTER, $K_r=90^\circ$

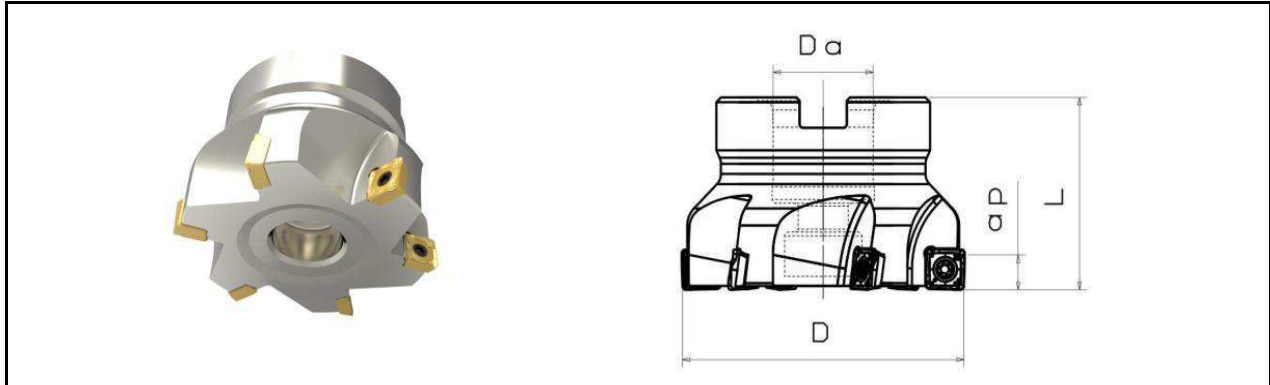

MODEL		DIMENSION				CONNECTOR		SUITABLE INSERT
		D	L	ap	Da			
HWM90SD-A22R-50-5	5	50	40	10	22	A	0.7	SDKT. 1404
HWM90SD-A22R-63-6	6	63	40	10	22	A	0.7	
HWM90SD-A27R-80-6	6	80	50	10	27	A	1.2	
HWM90SD-A27R-80-8	8	80	50	10	27	A	1.1	
HWM90SD-A32R-100-8	8	100	50	10	32	B	1.1	
HWM90SD-A32R-100-10	10	100	50	10	32	B	1.9	
HWM90SD-A40R-125-10	10	125	63	10	40	B	1.8	
HWM90SD-A40R-125-12	12	125	63	10	40	B	1.7	
HWM90SD-A40R-160-15	15	160	63	10	40	C	3.2	

©STANDARD CUTTER WITHOUT INTERNAL COOLANT

©INSERTS TO BE ORDERED SEPERATELY

INSERTS MODEL	EDGE LONG	DIMENSION					GRADE			
		d	S	bs	La	R	HW0622	HW1814	HW8240	HW8420
SDKT 140408	14	13.8	3.9	2.0	10.3	0.8	●	●	●	●

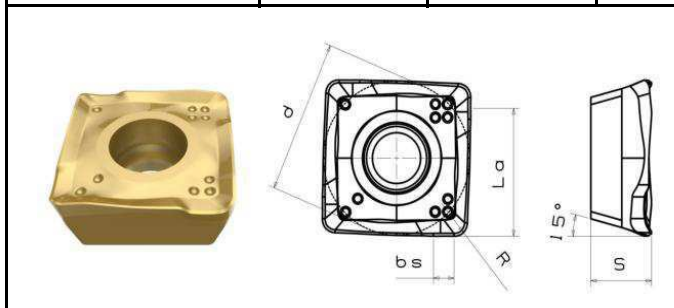

ACCESSORY

MODEL	SCREW	WRENCH
HWM90SD-14	M 3585-P	G. 10W-P

LN SERIES: HWM490LN



FACE MILL CUTTER, $K_r=90^\circ$

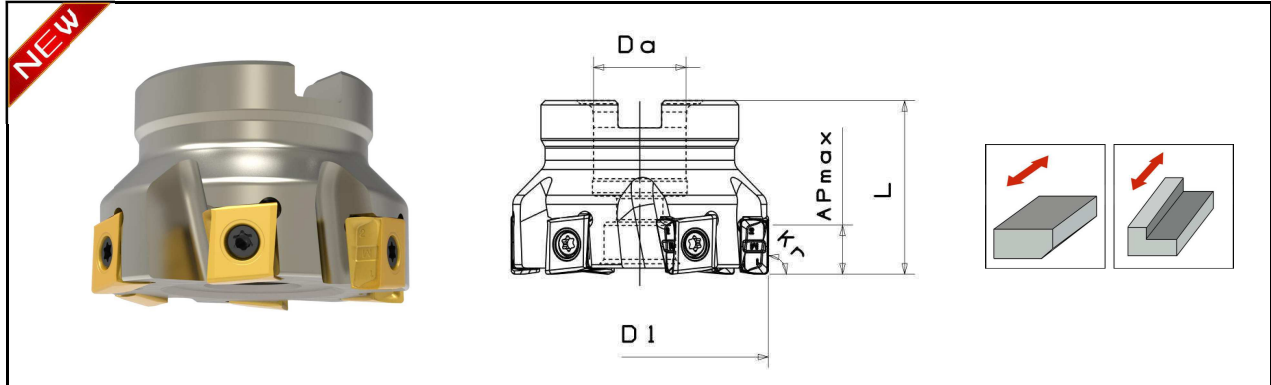

MODEL	kr		DIMENSION				CONNE CTOR	 Kg	SUITABLE INSERT
			D1	Da	L	APmax			
HWM490LN-A22R-50-5	90°	5	50	22	40	8.5	A	0.3	LNMU 0904
HWM490LN-A22R-50-7		7	50	22	40		A	0.4	
HWM490LN-A22R-63-6		6	63	22	40		A	0.5	
HWM490LN-A22R-63-10		10	63	22	40		A	0.5	
HWM490LN-A22R-50-4		4	50	22	40	11.5	A	0.3	LNMU 1206
HWM490LN-A22R-50-6		6	50	22	40		A	0.3	
HWM490LN-A22R-63-6		6	63	22	40		A	0.5	
HWM490LN-A22R-63-8		8	63	22	40		A	0.5	
HWM490LN-A27R-80-7		7	80	27	50		A	1.0	
HWM490LN-A27R-80-10		10	80	27	50		A	1.2	
HWM490LN-A32R-100-8		8	100	32	50		B	2.0	
HWM490LN-A32R-100-12		12	100	32	50		B	2.1	
HWM490LN-A40R-125-10		10	125	40	63	15.0	B	3.1	LNMU 1608
HWM490LN-A40R-125-14		14	125	40	63		B	3.4	
HWM490LN-A40R-160-11		11	160	40	63		C	4.1	
HWM490LN-A40R-160-14		14	160	40	63		C	4.3	
HWM490LN-A60R-200-12		12	200	60	63	15.0	C	5.7	LNMU 1608
HWM490LN-A60R-200-16		16	200	60	63		C	5.8	

©STANDARD. CUTTER WITHOUT. INTERNAL. COOLANT, INSERTS. TO BE ORDERED. SEPERATELY.

ACCESSORY

MODEL	SCREW	WRENCH
HWM490LN-09	M 3010	G 08W
HWM490LN-12	M 4013-P	G 15W-P
HWM490LN-16	M 5016	G 20W

LN SERIES: HWM490LN



FACE MILL CUTTER, $Kr=90^\circ$

LNHU INSERT

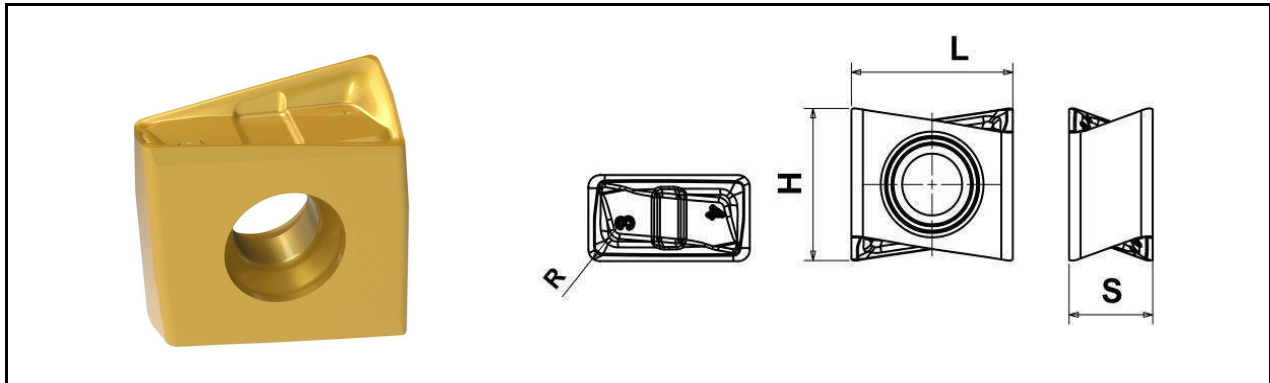

MODEL	EDGE LONG	KR (°)	DIMENSION					GRADE			
			L	H	S	R	APmax	HW0632	HW1804	HW8320	HW A7
LNMU 090404-M	09	90	9.02	8.55	4.48	0.4	8.5	●	●	●	
LNMU 120608-M	12		12.7	13.0	6.75	0.8	11.5	●	●	●	
LNMU 120612-M	12		12.7	13.0	6.75	1.2	11.5	●	●	●	
LNMU 120608-AL	12		12.7	13.0	6.75	0.8	11.5				●
LNMU 160808-M	16		16.4	16.2	8.0	0.8	15.0	●	●	●	

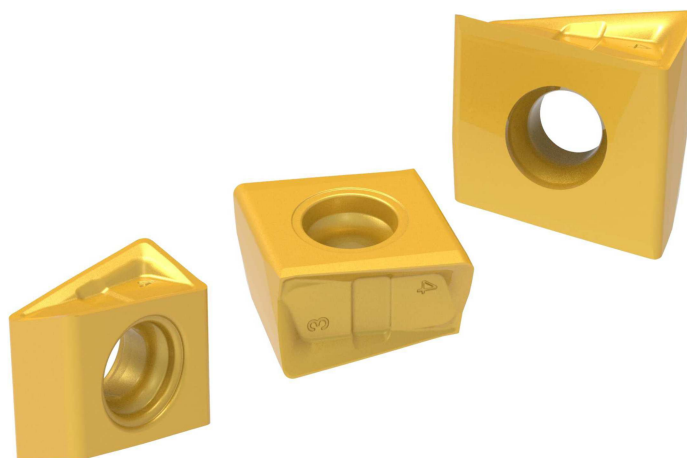

AN SERIES: HWM90AN



FACE MILL CUTTER, $Kr=90^\circ$

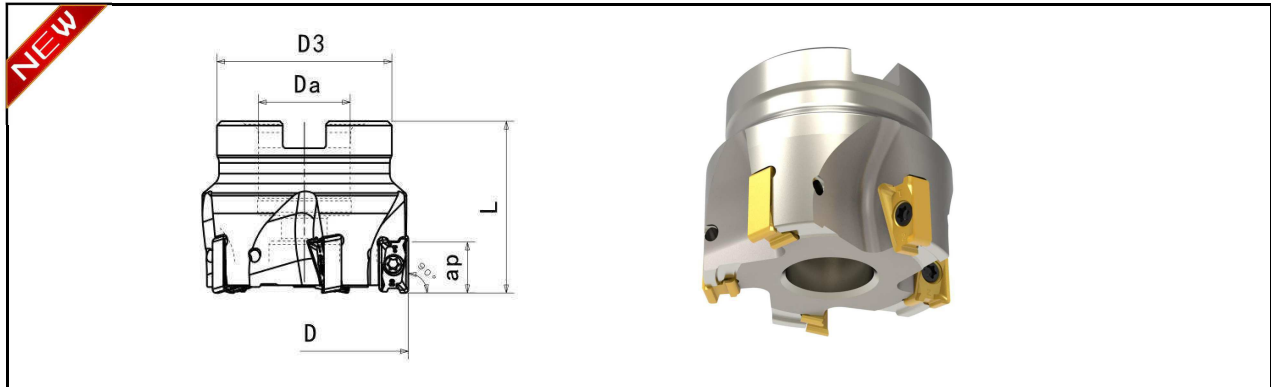

MODEL	KR		DIMENSION						SUITABLE INSERT	
			D	Da	D3	L	ap			
HWM90AN-A16R-40-4	90°		4	40	16	37	40	11.5	0.23	ANMU 1204
HWM90AN-A16R-40-6			6	40	16	37	40	11.5	0.22	
HWM90AN-A16R-40-7			7	40	16	37	40	11.5	0.23	
HWM90AN-A22R-50-5			5	50	22	42	40	11.5	0.31	
HWM90AN-A22R-50-7			7	50	22	42	40	11.5	0.32	
HWM90AN-A22R-50-9			9	50	22	42	40	11.5	0.32	
HWM90AN-A22R-63-6			6	63	22	50	40	11.5	0.56	
HWM90AN-A22R-63-9			9	63	22	50	40	11.5	0.56	
HWM90AN-A27R-80-8			8	80	27	60	50	11.5	1.12	
HWM90AN-A27R-80-10			10	80	27	60	50	11.5	1.11	

©STANDARD CUTTER WITHOUT INTERNAL COOLANT.

©INSERTS TO BE ORDERED SEPERATELY.

ACCESSORY

MODEL	SCREW	WRENCH
HWM90AN-**-12	M 3080	G. 10W

AN SERIES: HWM90AN



FACE MILL CUTTER, $K_r=90^\circ$

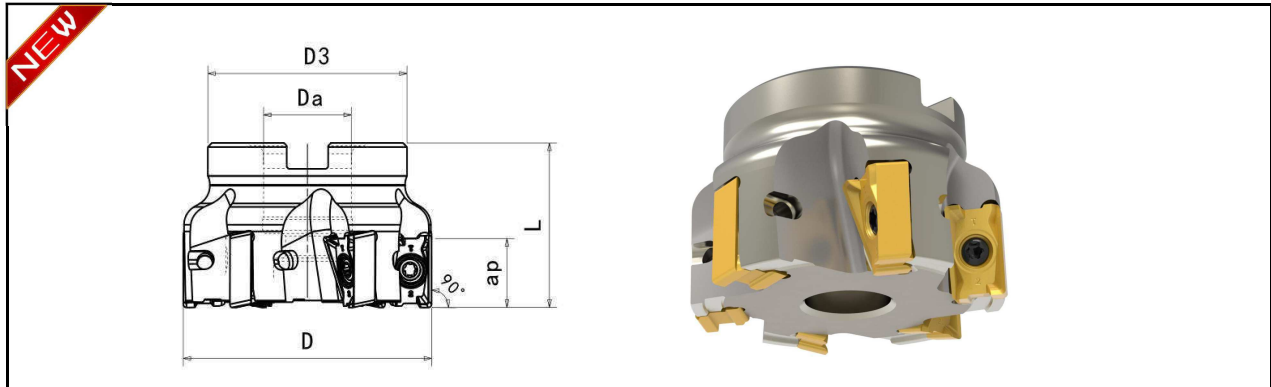

MODEL	KR		DIMENSION						SUITABLE INSERT
			D	Da	D3	L	ap		
HWM90AN-A16R-40-4	90°	4	40	16	38	40	16.5	0.20	ANMU 17T6 ANMU 17T6
HWM90AN-A16R-40-5		5	40	16	38	40	16.5	0.19	
HWM90AN-A22R-50-4		4	50	22	45	40	16.5	0.28	
HWM90AN-A22R-50-5		5	50	22	45	40	16.5	0.28	
HWM90AN-A22R-50-6		6	50	22	45	40	16.5	0.27	
HWM90AN-A22R-63-5		5	63	22	47	40	16.5	0.50	
HWM90AN-A22R-63-6		6	63	22	47	40	16.5	0.49	
HWM90AN-A22R-63-7		7	63	22	47	40	16.5	0.50	
HWM90AN-A27R-80-5		5	80	27	58	50	16.5	1.03	
HWM90AN-A27R-80-7		7	80	27	58	50	16.5	1.02	
HWM90AN-A27R-80-9		9	80	27	58	50	16.5	1.04	
HWM90AN-A32R-100-6		6	100	32	85	50	16.5	1.58	
HWM90AN-A32R-100-8		8	100	32	85	50	16.5	1.57	
HWM90AN-A32R-100-11		11	100	32	85	50	16.5	1.64	
HWM90AN-A40R-125-7		7	125	40	85	63	16.5	2.93	
HWM90AN-A40R-125-9		9	125	40	85	63	16.5	2.98	
HWM90AN-A40R-125-12		12	125	40	85	63	16.5	3.00	
HWM90AN-A40R-160-8		8	160	40	110	63	16.5	4.67	
HWM90AN-A40R-160-12		12	160	40	110	63	16.5	4.78	
HWM90AN-A40R-160-16		16	160	40	110	63	16.5	4.75	

©STANDARD CUTTER WITHOUT INTERNAL COOLANT; INSERTS TO BE ORDERED SEPERATELY.

ACCESSORY

MODEL	SCREW	WRENCH
	HWM90AN-**-17	M 4013

AN



INSERTS

AN INSERTS

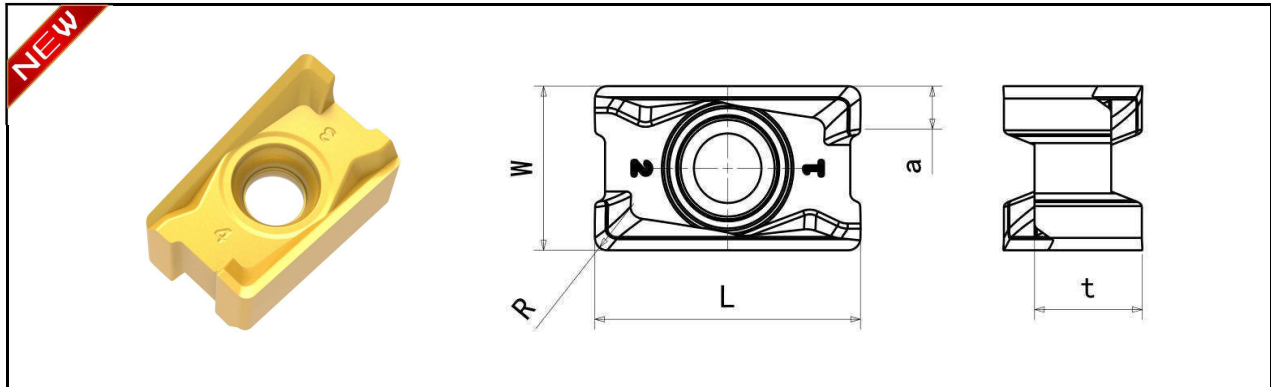

MODEL	EDGE LONG	kr	DIMENSION					GRADE				
			L	W	t	a	R	HW0632	HW0622	HW1804	HW8320	HW7519
ANMU 120404M	12	90°	12.55	7.0	4.84	1.7	0.4	●		●	●	
ANMU 120404M							0.4					
ANMU 120408M							0.8					
ANMU 120408MM							0.8					
ANMU 120412M							1.2					
ANMU 17T608M	17	90°	17.3	10.4	7.03	2.7	0.8	●		●	●	
ANMU 17T608MM							0.8					
ANMU 17T608MM							0.8					
ANMU 17T608M							0.8					
ANMU 17T608SM							0.8					
ANMU 17T616M							1.6					

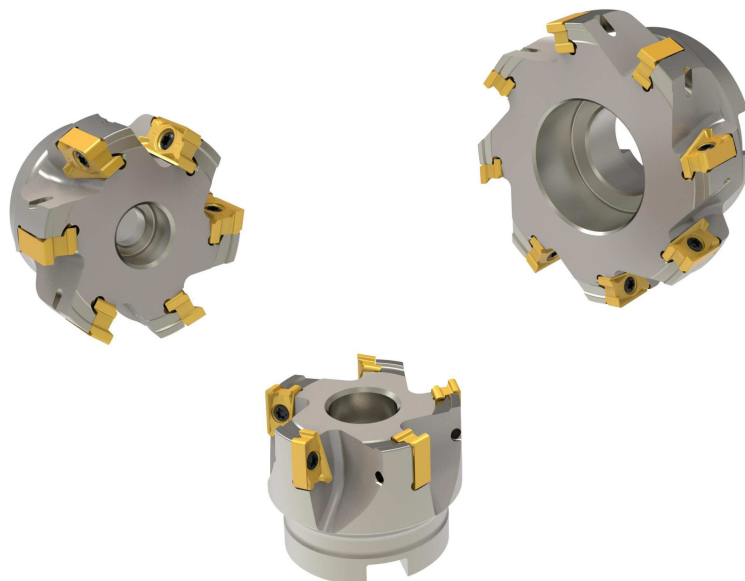

HWM88LN



FINE FINISHING FACE MILL CUTTER

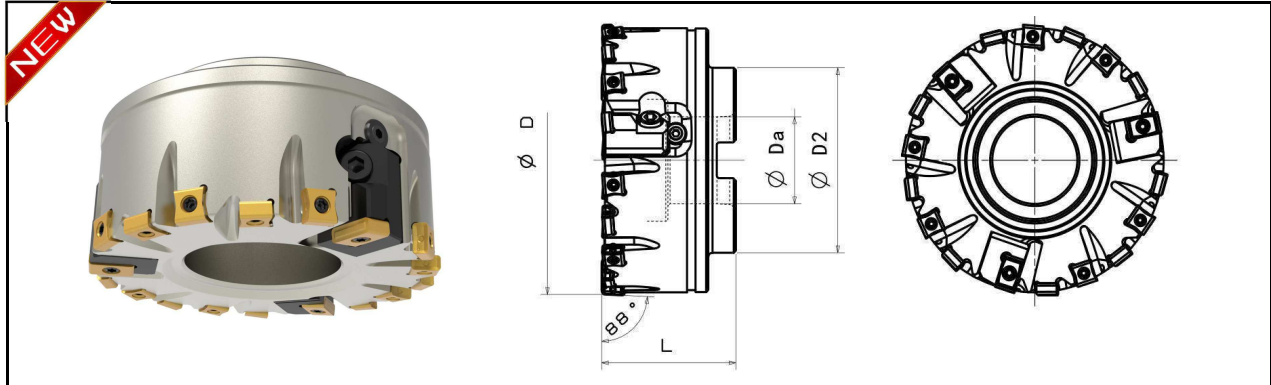

MODEL		DIMENSION				CONNE CTOR		SUITABLE INSERT
		D	Da	D2	L			
HWM88LN-A27R-80-10	2+8	80	27	58	50	A	2.0	LNMX 1005 LNMX 1504
HWM88LN-A32R-100-12	2+10	100	32	70	50	A	2.5	
HWM88LN-A40R-125-18	3+15	125	40	85	63	B	4.0	
HWM88LN-A40R-160-21	3+18	160	40	110	63	C	6.0	
HWM88LN-A60R-200-27	3+24	200	60	130	70	C	9.0	
HWM88LN-A60R-250-32	4+28	250	60	160	70	C	16.3	

©STANDARD. CUTTER WITHOUT INTERNAL COOLANT; INSERTS. TO BE ORDERED SEPERATELY; WITH CLAMP.

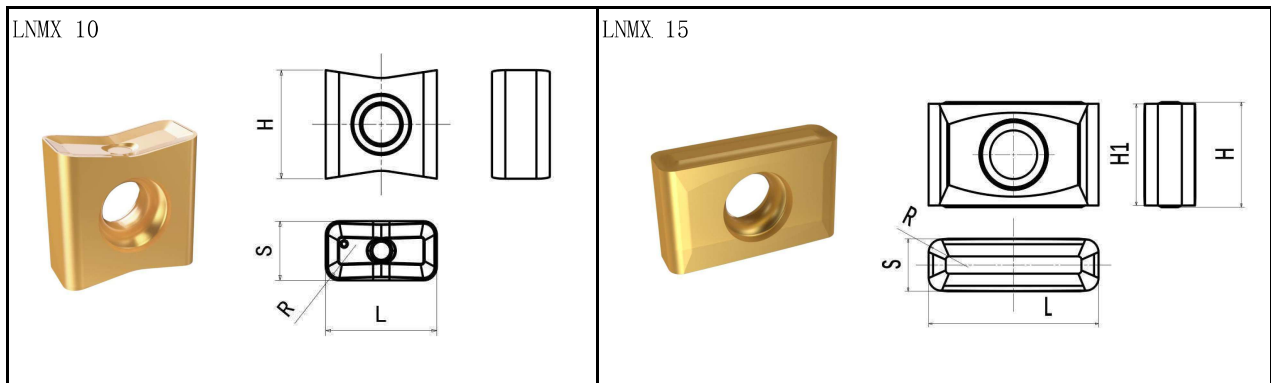

MODEL	EDGE LONG	DIMENSION					GRADE		ACCESSORY	
		L	H	H1	S	R	HW0632	HW1814	SCREW	WRENCH
LNMX 100512M	10	10.0	9.53	—	5.2	1.2	●		M 3080	G 10W
LNMX 1504R1.2M	15	15.87	9.37	9.52	4.76	1.2	●	●	M 4090	G 15W

MHW



MILLING CUTTER CLAMP SYSTEM

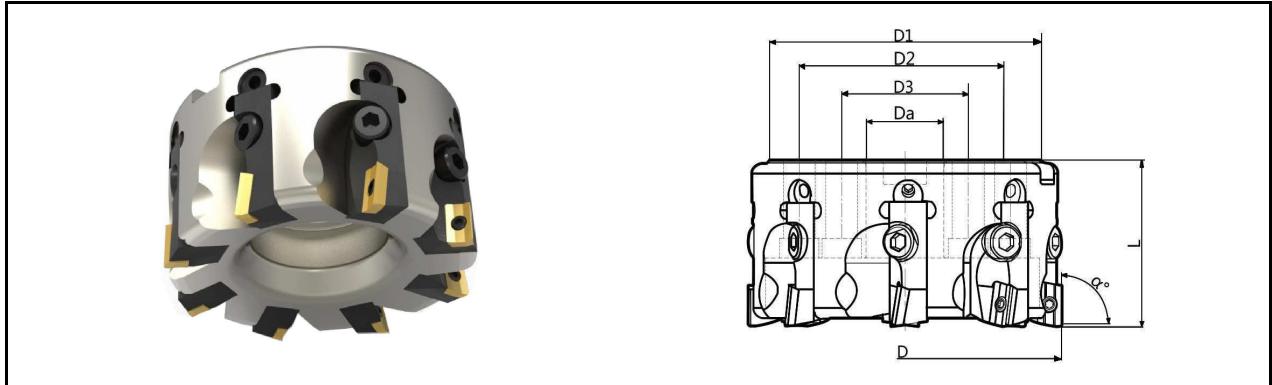

MODEL		DIMENSION						CONNE CTOR	 Kg	CLAMP MODEL
		D	Da	D3	D2	D1	L			
MHW-A40R-125-6	6	125	40	—	—	108	68	B	3.83	MHW-MA
MHW-A40R-125-8	8	125	40	—	—	108	68	B	3.54	
MHW-A40R-160-8	8	160	40	66.7	—	137	63	C	5.78	
MHW-A40R-160-12	12	160	40	66.7	—	137	63	C	5.20	
MHW-A60R-200-10	10	200	60	101.6	—	178	63	C	8.80	
MHW-A60R-200-14	14	200	60	101.6	—	178	80	C	12.57	
MHW-A60R-250-12	12	250	60	101.6	—	228	63	C	14.78	
MHW-A60R-250-18	18	250	60	101.6	—	228	63	C	13.93	
MHW-A60R-315-16	16	315	60	101.6	177.8	293	80	D	30.74	
MHW-A60R-315-22	22	315	60	101.6	177.8	293	80	D	25.42	
MHW-A60R-400-26	26	400	60	101.6	177.8	300	80	D	—	
MHW-A60R-500-40	40	500	60	101.6	177.8	300	80	D	—	

◎STANDARD CUTTER WITHOUT 1

◎CLAMP TO BE ORDERED SEPERATELY,

ACCESSORY

MODEL	CLAMP	WEDGE	WEDGE SCREW	MOUNT SCREW	WRENCH	WRENCH
MHW	 MHW-MA	 CYC12Y	 CLD0602010	 M 08025125	 CBL30	 G 15W

MHW-MA



MILL CUTTER CLAMP, COMPATIBLE WITH CZH SERIES

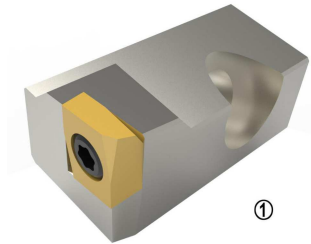

①

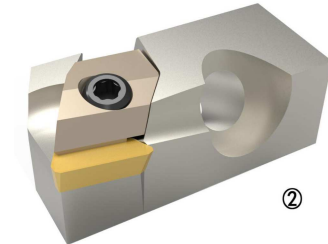

②

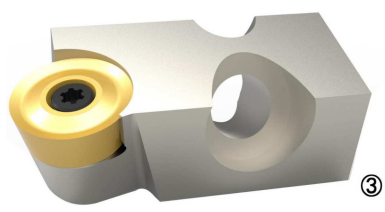

③

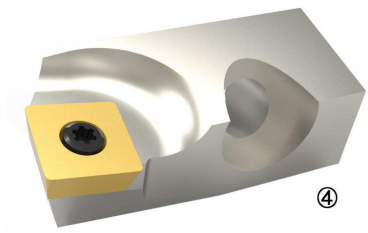

④

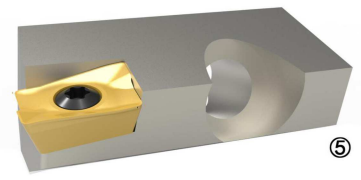

⑤



⑥

NO.	MODEL	INSERT
1	MHW-MDHX10CA	MDHX...10
2	MHW-TP1603CA	TP...1603
3	MHW-RP1605CA	RP...1605
4	MHW-SD1204CA	SD...1204
5	MHW-AD1505CA	AD...1505
6	MHW-LN1206CA	LN...1206

© INSERTS. TO. BE. ORDERED. SEPERATELY



- Roughing and finishing with one tool
- Quick tool holder fixing function
- Easy to adjust tool runout value
- Easy to change cartridges with different insert types and entering angles

ALUMINUM MILL CUTTER: HWM90PCD-L



ALUMINUM MILL CUTTER

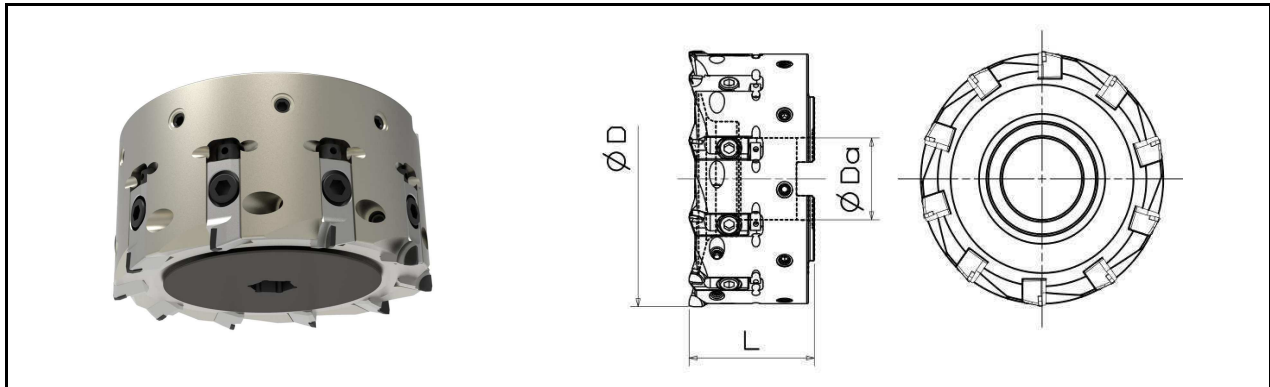

MODEL		DIMENSION					COMPATIBLE CLAMP
		D	Da	L	T _{max}		
HWM90PCD-A22R-63-4	4	63	22	48	4	0.80	WD-PCD-AL
HWM90PCD-A27R-80-6	6	80	27	50	4	0.75	
HWM90PCD-A32R-100-8	8	100	32	50	4	1.20	
HWM90PCD-A40R-125-10	10	125	40	63	4	2.20	
HWM90PCD-A40R-160-12	12	160	40	63	4	2.15	
HWM90PCD-A40R-180-14	14	180	40	63	4	2.60	
HWM90PCD-A60R-200-16	16	200	60	63	4	4.40	
HWM90PCD-A60R-250-18	18	250	60	63	4	7.00	
HWM90PCD-A60R-315-20	20	315	60	80	4	14.10	
HWM90PCD-A60R-400-22	22	400	60	80	4	22.10	

©STANDARD CUTTER WITH INNER COOLANT

©CLAMP TO BE ORDERED SEPERATLY, . STANDARD CUTTER NOT INCLUDING CLAMP.

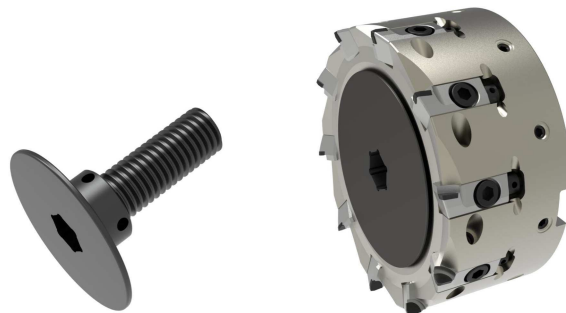

ACCESSORY

MODEL	CLAMP	CLAMP SCREW	WRENCH	CLAMP Dynamic balance adjustment screw
HWM90PCD-L	WD-PCD-AL	M 0601210	G 50/CBL30	M 0600610

ALUMINUM MILL CUTTER: HWM90AE



ALUMINUM MILL CUTTER

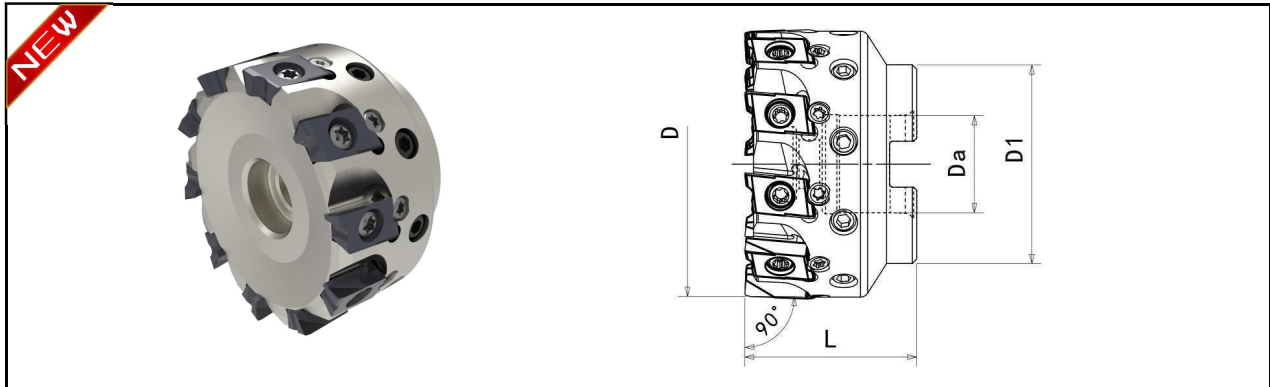

MODEL		DIMENSION					Kg	MATERIAL	INSERT
		D	Da	D1	L	APmax			
HWM90AE-A16R-40-6	6	40	16	36	40	11	0.36	STEEL	AEMT. 1504
HWM90AE-A22R-50-8	8	50	22	45	40	11	0.55		
HWM90AE-A22R-63-10	10	63	22	45	40	11	0.75		

©STANDARD. CUTTER WITH INTERNAL COOLANT

©INSERTS TO BE ORDERED SEPERATELY

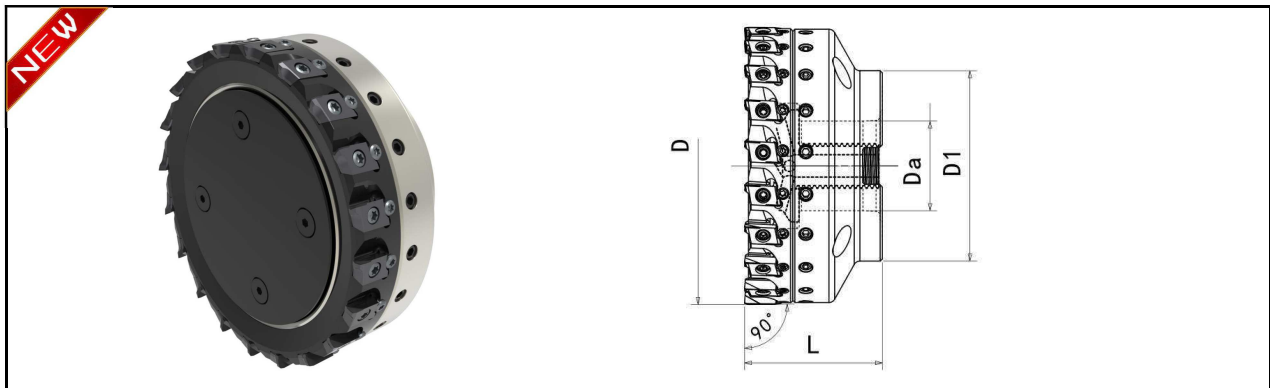

MODEL		DIMENSION					Kg	MATERIAL	INSERT
		D	Da	D1	L	APmax			
HWM90AE-A27R-80-12	12	80	27	50	50	11	0.96	STEEL. RIGHT + ALU. ALLOY BODY	AEMT. 1504
HWM90AE-A32R-100-16	16	100	32	70	50	11	1.45		
HWM90AE-A40R-125-20	20	125	40	90	63	11	2.40		
HWM90AE-A40R-160-24	24	160	40	115	63	11	3.00		
HWM90AE-A60R-200-30	30	200	60	150	63	11	4.25		
HWM90AE-A60R-250-36	36	250	60	200	63	11	6.50		

©STANDARD. CUTTER WITH INTERNAL COOLANT

©INSERTS TO BE ORDERED SEPERATELY

ALUMINUM MILL CUTTER: HWM90AE



ALUMINUM MILL CUTTER



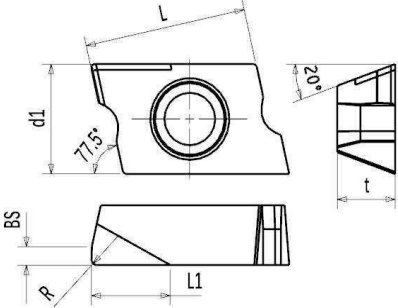

MODEL	EDGE LENGTH	WIPER	KR	DIMENSION						EDGE MATERIAL
				L	d1	t	R	L1	BS	
AEMT 1504XPCD	15	YES	90	14.0	9.2	5.0	0.4	6.8	1.54	PCD

CUTTER DIA	COVER BOLT	RING SCREW	WRENCH
40-63	M 10	—	—
80	M 12	Z 0510	G 25
100	M 16	Z 0610	G 30
125	M 20	Z 0810	G 40
160	M 24	Z 0810	G 40
200	M 28	Z 0810	G 40
250	M 32	Z 0810	G 40



ACCESSORY

MODEL	DIA	INSERT SCR.	Mir-adj. sc.	WRENCH	balance s.	WRENCH	steel wire
HWM90AE	40-63	M 4013-P	M 3011-P	G 15W-P	Z 0600610	T 30	—
	80-250						C060

FAST FEED SERIES : HWMBL



FAST FEED MILL CUTTER



MODEL		DIMENSION				CONNE CTOR	Kg	INSERT
		D	da	L	ap			
HWMMBL-A16R-32-4	4	32	16	40	1.0	A	0.1	BLMP. 0603
HWMMBL-A16R-32-5	5	32	16	40	1.0	A	0.1	
HWMMBL-A16R-40-6	6	40	16	40	1.0	A	0.2	
HWMMBL-A16R-40-6	6	40	22	40	1.0	A	0.2	
HWMMBL-A22R-50-6	6	50	22	50	1.0	A	0.4	
HWMMBL-A22R-50-7	7	50	22	50	1.0	A	0.4	
HWMMBL-A22R-50-8	8	50	22	50	1.0	A	0.4	
HWMMBL-A22R-52-7	7	52	22	40	1.0	A	0.4	
HWMMBL-A22R-52-8	8	52	22	40	1.0	A	0.4	
HWMMBL-A22R-63-7	7	63	22	50	1.0	A	0.6	
HWMMBL-A22R-63-8	8	63	22	50	1.0	A	0.6	
HWMMBL-A22R-63-9	9	63	22	50	1.0	A	0.6	
HWMMBL-A27R-66-9	9	66	27	50	1.0	A	0.7	
HWMMBL-A16R-40-4	4	40	16	40	1.5	A	0.2	BLMP. 0904
HWMMBL-A16R-40-5	5	40	16	40	1.5	A	0.2	
HWMMBL-A22R-50-5	5	50	22	50	1.5	A	0.4	
HWMMBL-A22R-50-6	6	50	22	50	1.5	A	0.4	
HWMMBL-A22R-50-7	7	50	22	50	1.5	A	0.4	
HWMMBL-A22R-52-6	6	52	22	40	1.5	A	0.4	
HWMMBL-A22R-52-7	7	52	22	40	1.5	A	0.4	
HWMMBL-A22R-63-6	6	63	22	50	1.5	A	0.4	
HWMMBL-A22R-63-7	7	63	22	50	1.5	A	0.4	

©STANDARD CUTTER WITHOUT 1

©INSERTS TO BE ORDERED SEPARATELY

FAST FEED SERIES: TFMBL



FAST FEED MILL CUTTER



MODEL		DIMENSION				CONNE CTOR		INSERT
		D	da	L	ap			
HWMMBL-A22R-63-8	8	63	22	50	1.5	A	0.6	BLMP. 0904
HWMMBL-A27R-66-7	7	66	27	50	1.5	A	0.7	
HWMMBL-A27R-66-8	8	66	27	50	1.5	A	0.8	
HWMMBL-A27R-80-7	7	80	27	50	1.5	A	1.2	
HWMMBL-A27R-80-8	8	80	27	50	1.5	A	1.2	
HWMMBL-A27R-80-9	9	80	27	50	1.5	A	1.2	
HWMMBL-A27R-80-10	10	80	27	50	1.5	A	1.2	
HWMMBL-A32R-100-8	8	100	32	60	1.5	A	2.3	
HWMMBL-A32R-100-9	9	100	32	60	1.5	A	2.3	
HWMMBL-A32R-100-10	10	100	32	60	1.5	A	2.3	
HWMMBL-A32R-100-11	11	100	32	60	1.5	A	2.3	
HWMMBL-A32R-100-12	12	100	32	60	1.5	A	2.3	
HWMMBL-A40R-125-12	12	125	40	60	1.5	A	2.7	
HWMMBL-A40R-125-14	14	125	40	60	1.5	A	2.7	

©STANDARD CUTTER WITHOUT 1

©INSERTS TO BE ORDERED SEPARATELY

ACCESSORY

MODEL	SCREW	WRENCH
BL-06	M 2560	G 08W
BL-09	M 3581	G 15W

FAST FEED SERIES: HWMBL



FAST FEED MILL CUTTER

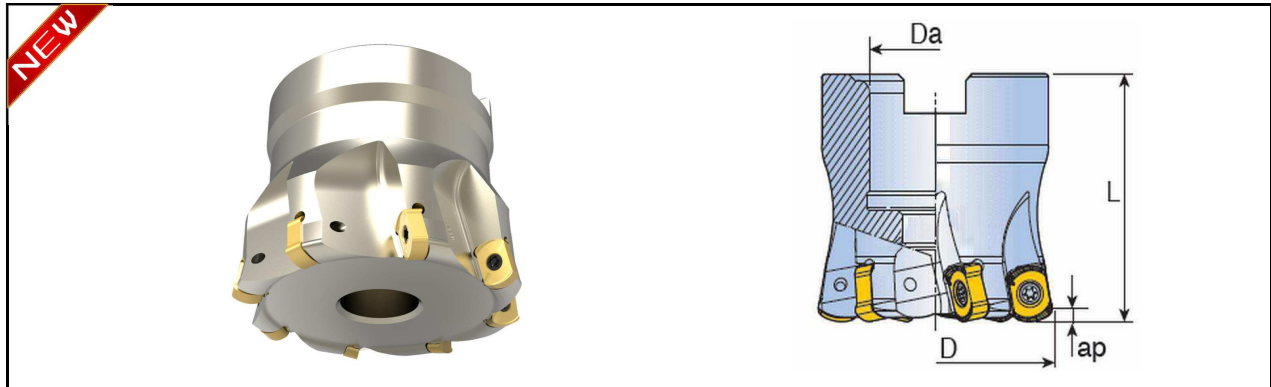

MODEL		DIMENSION				CONNE CTOR		INSERT
		D	da	L	ap			
HWMMBL-A16R-40-4	4	40	16	40	2.0	A	0.2	BLMP. 1105
HWMMBL-A22R-50-4	4	50	22	40	2.0	A	0.3	
HWMMBL-A22R-50-5	5	50	22	40	2.0	A	0.3	
HWMMBL-A22R-52-5	5	52	22	40	2.0	A	0.3	
HWMMBL-A22R-63-5	5	63	22	50	2.0	A	0.7	
HWMMBL-A22R-63-6	6	63	22	50	2.0	A	0.7	
HWMMBL-A27R-66-6	6	66	22	50	2.0	A	0.83	
HWMMBL-A27R-80-6	6	80	27	60	2.0	A	1.4	
HWMMBL-A27R-80-7	7	80	27	60	2.0	A	1.4	
HWMMBL-A32R-100-6	6	100	32	60	2.0	B	2.2	
HWMMBL-A32R-100-7	7	100	32	60	2.0	B	2.2	

©STANDARD. CUTTER WITHOUT]

©INSERTS. TO BE ORDERED. SEPARATELY

ACCESSORY

MODEL	SCREW	WRENCH
BL-11	M 5012	G. 20W

FAST FEED SERIES: TFMBL

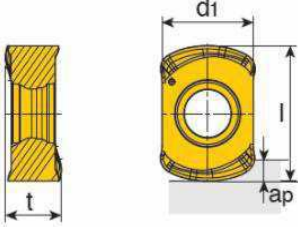

FAST FEED MILL CUTTER

INSERT	SHAPE		INTRODUCTION							
			FAST FEED INSERT							
MODEL	EDGE LONG	DIMENSION						GRADE		
		l	d1	t	ap	FEED mm/TEETH	CUT DEP.	HW0632	HW0622	HW9183
BLMP 0603R-M	06	9.0	6.39	3.73	1.0	0.3-2.5	0.1-1.0	●	●	●
BLMP 0603R-MM	06	9.0	6.39	3.73	1.0	0.3-2.5	0.1-1.0	●	●	●
BLMP 0904R-M	09	11.9	9.18	4.80	1.5	0.3-3.5	0.1-1.5	●	●	●
BLMP 0904R-MM	09	11.9	9.18	4.80	1.5	0.3-3.5	0.1-1.5	●	●	●
BLMP 1105R-ML	11	14.6	11.2	6.54	2.0	0.3-4.0	0.3-2.0	●	●	●
BLMP 1105R-M	11	14.6	11.2	6.54	2.0	0.3-4.0	0.3-2.0	●	●	●

PD SERIES: HWM19PD



FAST FEED MILL CUTTER, $K_r=19^\circ$

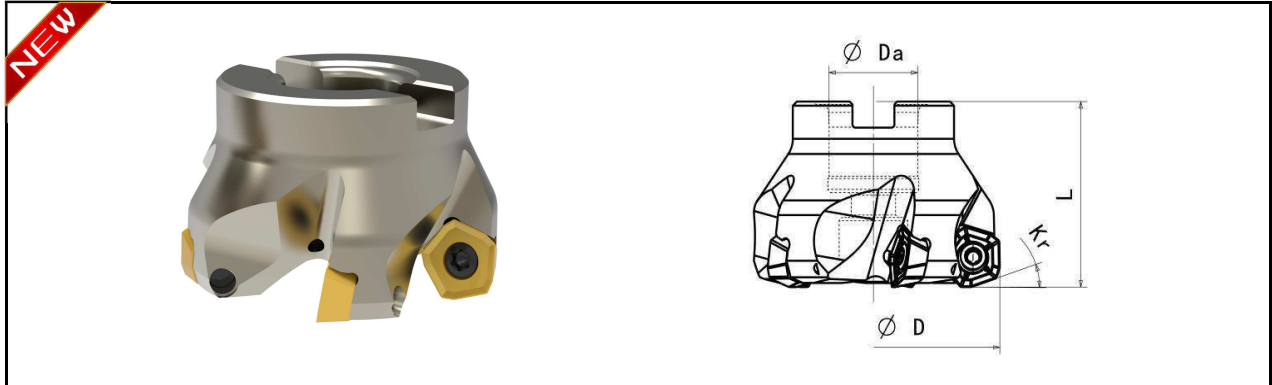

MODEL		DIMENSION				CONNE CTOR	Kg	INSERT
		D	Da	L	K_r°			
HWM19PD-A16R-42-3	3	42	16	40	19	A	0.18	PDGT. 0905
HWM19PD-A22R-50-4	4	50	22	40			0.23	
HWM19PD-A22R-52-4	4	52	22	40			0.24	
HWM19PD-A22R-63-5	5	63	22	40			0.31	
HWM19PD-A27R-66-6	6	66	22	40			0.32	
HWM19PD-A27R-80-5	5	80	27	50			0.83	
HWM19PD-A32R-100-6	6	100	32	50		B	1.40	
HWM19PD-A32R-100-8	8	100	32	50			1.38	

©STANDARD. CUTTER WITHOUT. INTERNAL. COOLANT

©INSERTS. TO. BE. ORDERED. SEPARATELY

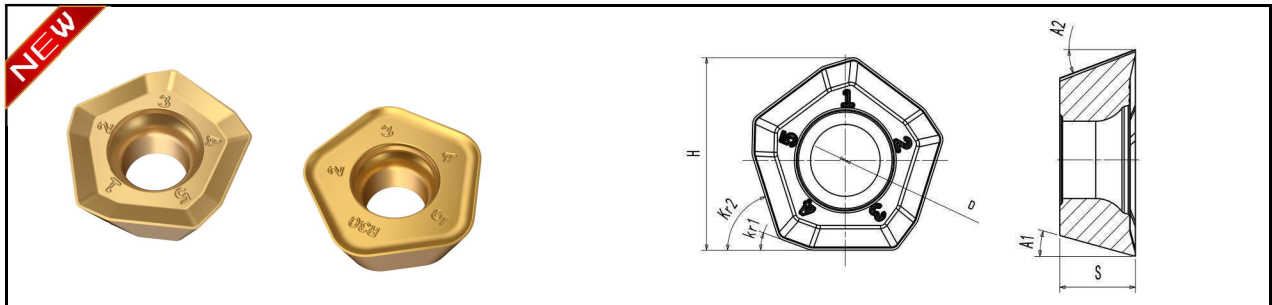

MODEL	DIMENSION							GRADE			SCREW/WRENCH
	D	H	S	K_r1°	K_r2°	$A1^\circ$	$A2^\circ$	HW0622	HW1804	HW8320	
PDGT 090508M	13.5	14.46	5.45	19	72	15	20	●			M 5012 G. 20W
PDGT 090508M	13.5	14.46	5.45	19	72	15	20	●			
PDGT 090530M	13.5	14.46	5.45		72	15	20	●			

FAST FEED SERIES: HMBL



Fast feed end mill shank

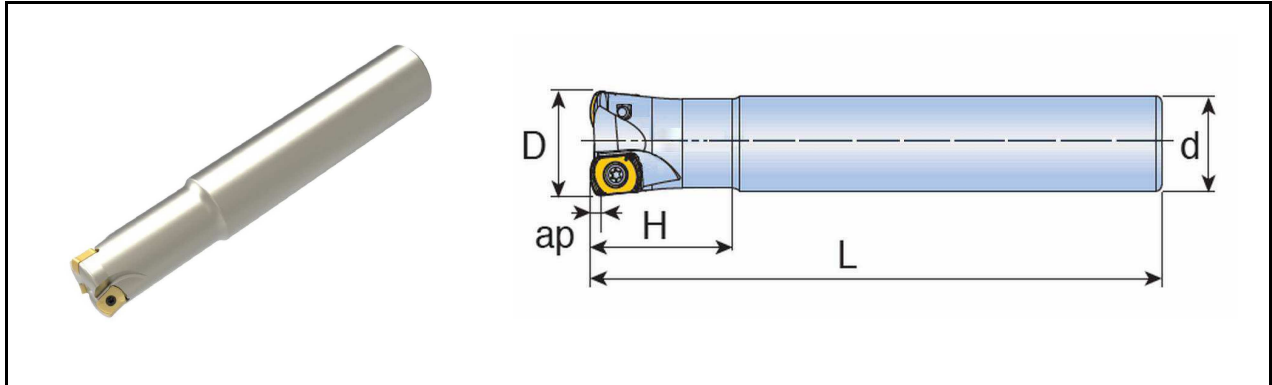

MODEL		DIMENSION						INSERT	
		D	d	L	H	ap			
HMBL 216-15-06-L150	2	16	15	150	40	0.7			BLMP. 0603
HMBL 216-16-06	2	16	16	150	40	0.7			
HMBL 216-16-06-S	2	16	16	100	30	0.7			
HMBL 217-16-06-S	2	17	16	100	30	0.7			
HMBL 217-16-06	2	17	16	150	40	0.7			
HMBL 217-16-06-L200	2	17	16	200	20	0.7			
HMBL 218-16-06	2	18	16	150	25	0.7			
HMBL 220-20-06-L200	2	20	20	200	80	1.0			
HMBL 320-19-06-L180	3	20	19	180	80	1.0			
HMBL 320-20-06-S	3	20	20	130	50	1.0			
HMBL 320-20-06	3	20	20	160	80	1.0			
HMBL 321-20-06-S	3	21	20	150	20	1.0			
HMBL 321-20-06-L200	3	21	20	200	20	1.0			
HMBL 325-25-06-L220	3	25	25	220	50	1.0			
HMBL 425-24-06-L180	4	25	24	180	60	1.0			
HMBL 425-25-06-S	4	25	25	140	60	1.0			
HMBL 425-25-06	4	25	25	180	60	1.0			
HMBL 425-25-06-L250	4	25	25	250	40	1.0			
HMBL 326-25-06-L200	3	26	25	200	30	1.0			
HMBL 326-25-06-L250	3	26	25	250	30	1.0			
HMBL 426-25-06-S	4	26	25	150	30	1.0			
HMBL 426-25-06-L200	4	26	25	200	30	1.0			
HMBL 426-25-06-L250	4	26	25	250	30	1.0			
HMBL 530-32-06-S	5	30	32	150	70	1.0			

©STANDARD SHANK WITHOUT INTERNAL COOLAN

©INSERTS TO BE ORDERED SEPARATELY

FAST FEED SERIES: HMBL



Fast feed end mill shank

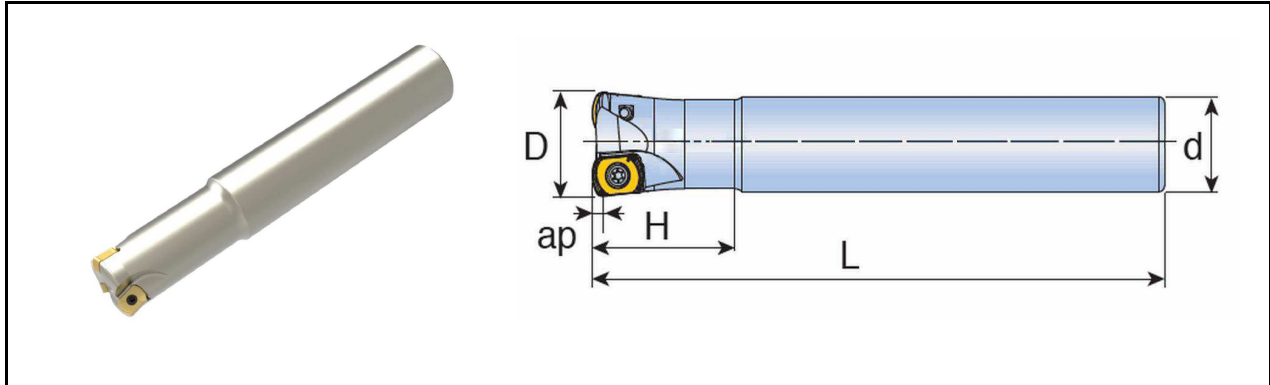

MODEL		DIMENSION							INSERT
		D	d	L	H	ap			
HMBL 430-32-06-S	4	30	32	150	70	1.0			BLMP. 0603
HMBL 430-32-06-L200	4	30	32	200	120	1.0			
HMBL 530-32-06-L200	5	30	32	200	120	1.0			
HMBL 432-32-06-S	4	32	32	150	70	1.0			
HMBL 532-32-06-S	5	32	32	150	70	1.0			
HMBL 532-32-06-L200	5	32	32	200	120	1.0			
HMBL 433-32-06-L220	4	33	32	220	40	1.0			
HMBL 433-32-06-L300	4	33	32	300	50	1.0			
HMBL 533-32-06-S	5	33	32	150	30	1.0			
HMBL 533-32-06-L200	5	33	32	200	40	1.0			
HMBL 533-32-06-L250	5	33	32	250	40	1.0			
HMBL 435-32-06-L200	4	35	32	200	50	1.0			
HMBL 435-32-06-L300	4	35	32	300	50	1.0			
HMBL 535-32-06-L200	5	35	32	200	50	1.0			
HMBL 535-32-06-L300	5	35	32	300	50	1.0			
HMBL 540-32-06-L220	5	40	32	220	40	1.0			
HMBL 640-32-06-S	6	40	32	150	40	1.0			
HMBL 640-32-06-L220	6	40	32	220	40	1.0			

©STANDARD. SHANK WITHOUT. INTERNAL. COOLANT

©INSERTS. TO. BE. ORDERED. SEPARATELY

FAST FEED SERIES: HWBL



Fast feed end mill shank

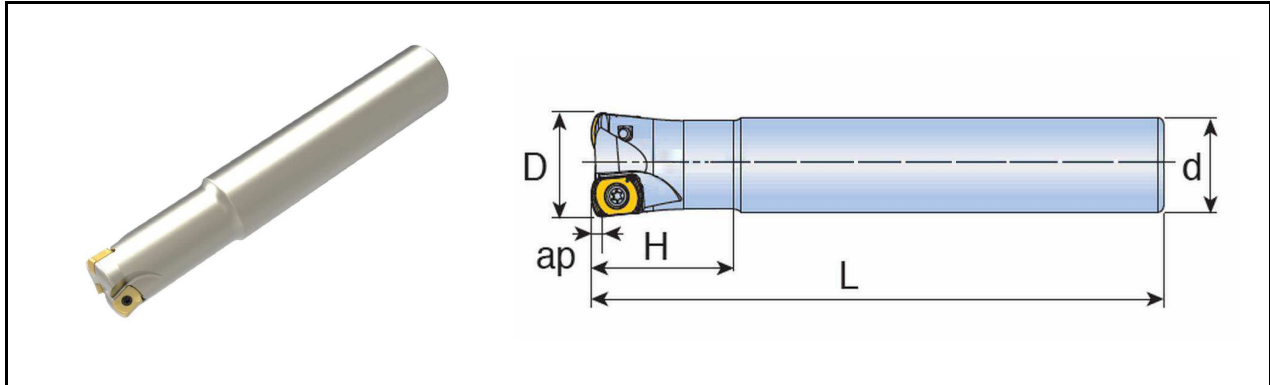

MODEL		DIMENSION							INSERT
		D	d	L	H	ap			
HMBL 225-25-09-L150	2	25	25	150	70	1.5			BLMP. 0904
HMBL 225-25-09-L200	2	25	25	200	100	1.5			
HMBL 325-25-09-L150	3	25	25	150	70	1.5			
HMBL 325-25-09-L200	3	25	25	200	110	1.5			
HMBL 326-25-09-L150	3	26	25	150	30	1.5			
HMBL 326-25-09-L220	3	26	25	220	30	1.5			
HMBL 330-32-09-L160	3	30	32	160	70	1.5			
HMBL 330-32-09-L220	3	30	32	220	120	1.5			
HMBL 332-32-09-L160	3	32	32	160	70	1.5			
HMBL 332-32-09-L220	3	32	32	220	120	1.5			
HMBL 432-32-09-L160	4	32	32	160	70	1.5			
HMBL 432-32-09-L220	4	32	32	220	120	1.5			
HMBL 433-32-09-L180	4	33	32	180	30	1.5			
HMBL 433-32-09-L250	4	33	32	250	30	1.5			
HMBL 440-32-09-L180	4	40	32	180	40	1.5			
HMBL 440-32-09-L250	4	40	32	250	40	1.5			
HMBL 540-32-09-L180	5	40	32	180	40	1.5			
HMBL 540-32-09-L250	5	40	32	250	40	1.5			

©STANDARD. SHANK WITHOUT. INTERNAL COOLANT; INSE . T . B . O . S

ACCESSORY

MODEL	SCREW	WRENCH
HWBL-06	M 2560	G. 08W
HWBL-09	M 3581	G. 15W

FAST FEED SERIES: HWMBL



Fast feed milling cutter thread head

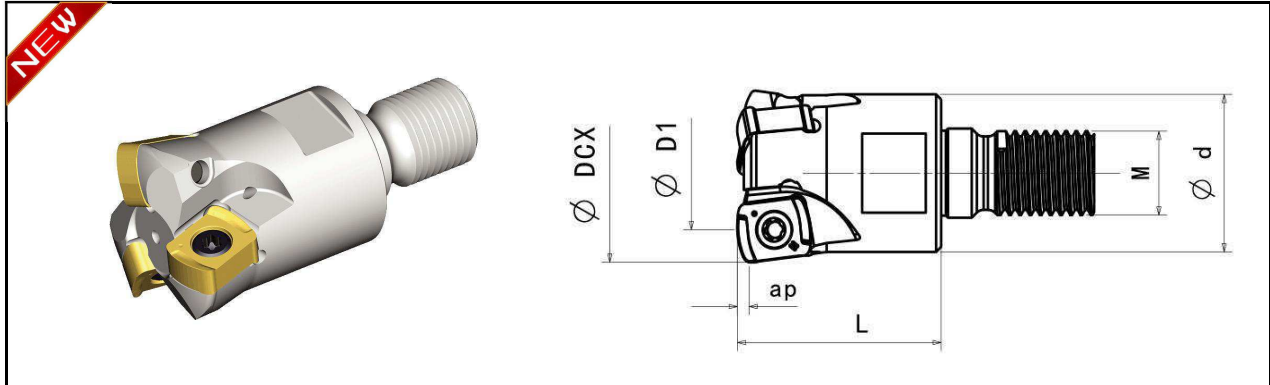

MODEL		DIMENSION							INSERT
		DCX	D1	L	d	ap	M		
HWBL 230-M16-11	2	30	14.7	43	29	2.0	16	BLMP. 1105	
HWBL 232-M16-11	2	32	16.6	43	29	2.0	16		
HWBL 233-M16-11	2	33	17.6	43	29	2.0	16		
HWBL 335-M16-11	3	35	19.5	43	29	2.0	16		
HWBL 340-M16-11	3	40	24.4	43	29	2.0	16		
HWBL 342-M16-11	3	42	26.4	43	29	2.0	16		

STANDARD SHANK WITHOUT INTERNAL COOLANT

INSERTS TO BE ORDERED SEPARATELY

INSERT	SHAPE		INTRODUCTION							
			FAST FEED INSERT							
MODEL	EDGE LONG	DIMENSION						GRADE		
		l	d1	t	ap	FEED mm/TEETH	CUT DEP. mm	HW0632	HW0622	HW9183
BLMP 0603R-M	06	9.0	6.39	3.73	1.0	0.3-2.5	0.1-1.0	●	●	●
BLMP 0603R-MM	06	9.0	6.39	3.73	1.0	0.3-2.5	0.1-1.0	●	●	●
BLMP 0904R-M	09	11.9	9.18	4.80	1.5	0.3-3.5	0.1-1.5	●	●	●
BLMP 0904R-MM	09	11.9	9.18	4.80	1.5	0.3-3.5	0.1-1.5	●	●	●
BLMP 1105R-ML	11	14.6	11.2	6.54	2.0	0.3-4.0	0.3-2.0	●	●	●
BLMP 1105R-M	11	14.6	11.2	6.54	2.0	0.3-4.0	0.3-2.0	●	●	●

AP17SERIES: WM90AP



END MILL CUTTER HOLDER

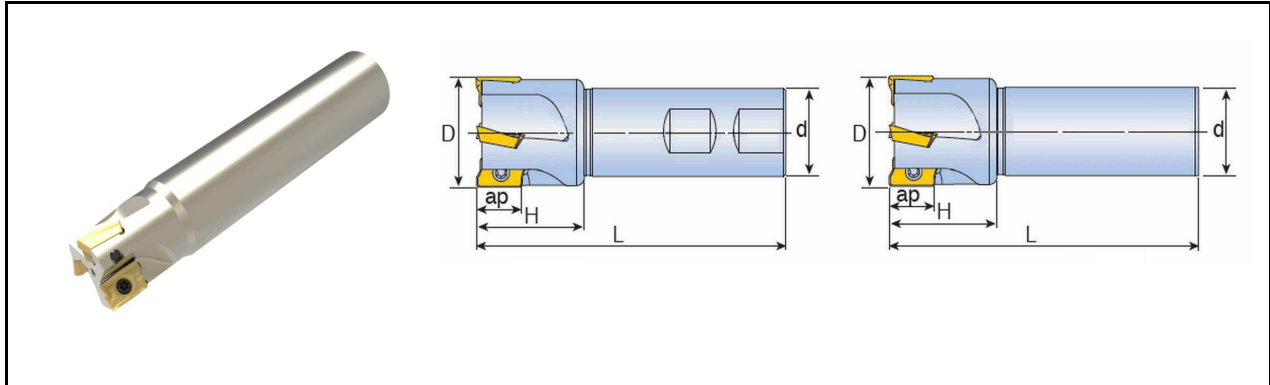

MODEL		DIMENSION					PIC	SUITABLE INSERT
		D	d	L	H	ap		
WM90AP-225L210Y24R-17	2	25	24	210	40	16.1	APKT. 1705	
WM90AP-225L210Y25R-17	2	25	25	210	40	16.1		
WM90AP-226L200Y25R-17	2	26	25	200	40	16.1		
WM90AP-226L250Y25R-17	2	26	25	250	40	16.1		
WM90AP-232L250Y32R-17	2	32	32	250	65	16.1		
WM90AP-233L300Y32R-17	2	33	32	300	40	16.1		
WM90AP-332L200Y32R-17	3	32	32	200	65	16.1		
WM90AP-333L200Y32R-17	3	33	32	200	55	16.1		
WM90AP-333L250Y32R-17	3	33	32	250	55	16.1		
WM90AP-240L250Y32R-17	2	40	32	250	54	16.1		
WM90AP-340L200Y32R-17	3	40	32	200	54	16.1		
WM90AP-440L200Y32R-17	4	40	32	200	57	16.1		

STANDARD CUTTER WITHOUT I . C

PIC 2 IS STANDARD.

INSERTS TO BE ORDERED SEPARATELY

ACCESSORY

MODEL	SCREW	WRENCH
WM90AP	M 4090	G. 15W

APKT



INSERT

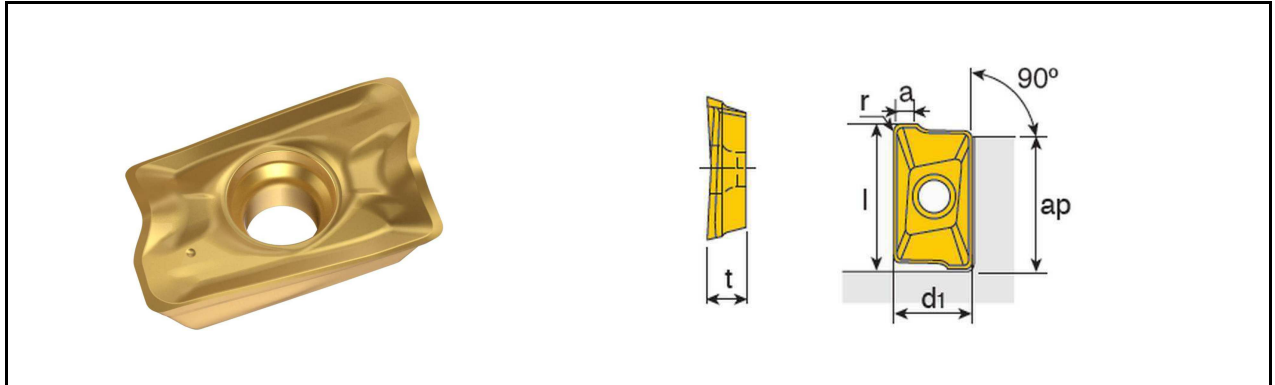

MODEL	EDGE LENGTH	DIMENSION						GRADE			
		d	ap	L	t	a	r	HW0632	HW1814	HW8320	HW7519
APKT 1705PER-M	17	10.7	16.1	18.5	5.56	3.0	0.8	●	●		

WN04SERIES: WM90WN



END MILL CUTTER HOLDER

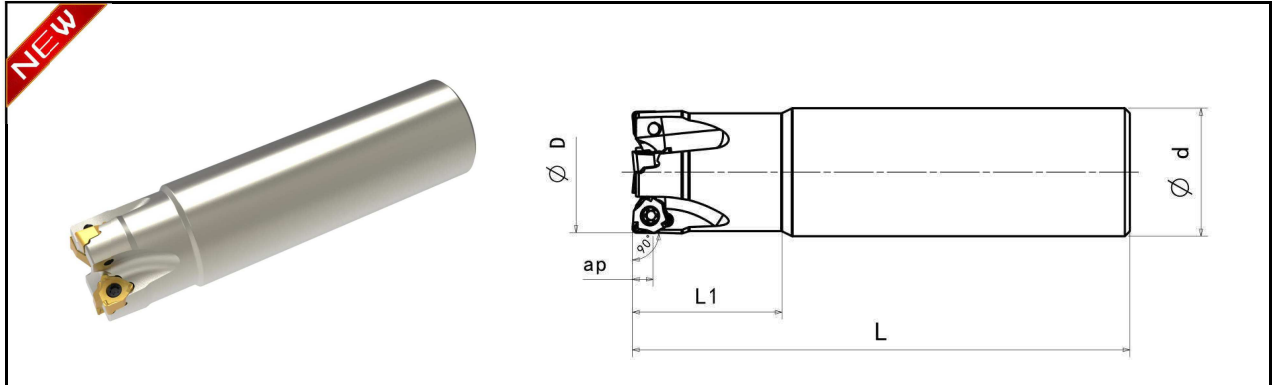

MODEL		DIMENSION					WEIGHT	SUITABLE INSERT
		D	d	L	H	ap		
WM90WN-220L150Y20R-04	2	20	20	150	29	4.0	0.7	WNHX 0403
WM90WN-320L150Y20R-04	3	20	20	150	29	4.0	0.7	
WM90WN-425L170Y25R-04	4	25	25	170	29	4.0	0.6	
WM90WN-525L170Y25R-04	5	25	25	170	29	4.0	0.6	
WM90WN-532L195Y32R-04	5	32	32	195	31	4.0	1.2	
WM90WN-632L195Y32R-04	6	32	32	195	31	4.0	1.2	

STANDARD CUTTER WITHOUT INTERNAL COOLANT

INSERTS TO BE ORDERED SEPARATELY

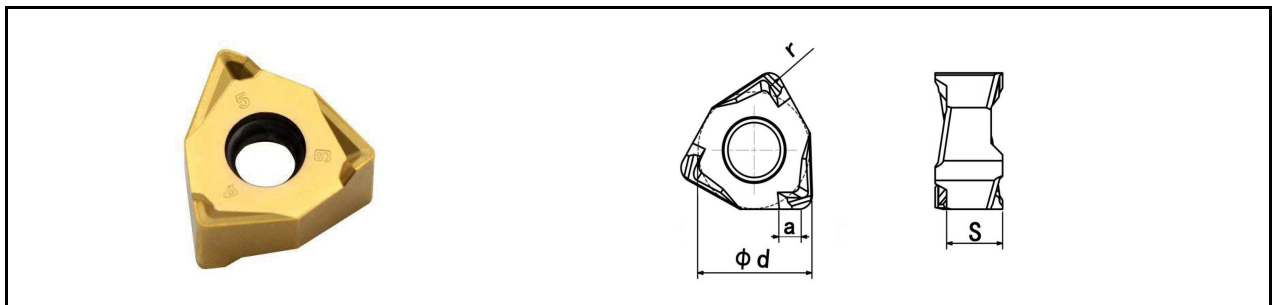

MODEL	EDGE LENGT H	DIMENSION				GRADE				
		d	r	S	a	HW0632	HW1814	HW8320	HW8420	HW1814
WNHX 040308-M	04	7.64	0.8	3.29	1.1	●	●			

WN04SERIES: WM90WN



END MILL CUTTER HOLDER

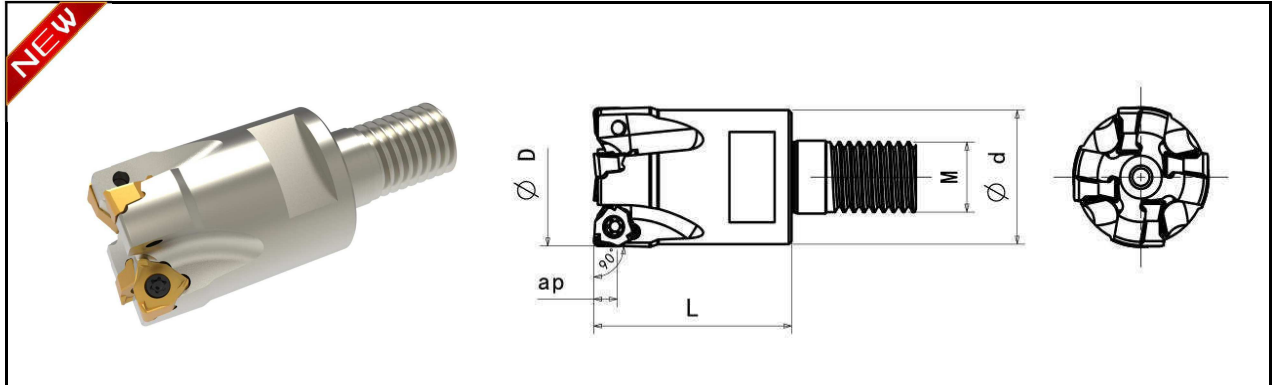

MODEL		DIMENSION					WEIGHT	SUITABLE INSERT
		D	d	L	M	ap		
WM90WN-220M10R-04	2	20	18.3	28	M10	4.0	0.1	WNHX 0403
WM90WN-320M10R-04	3	20	18.3	28	M10	4.0	0.1	
WM90WN-425M12R-04	4	25	23	30	M12	4.0	0.2	
WM90WN-525M12R-04	5	25	23	30	M12	4.0	0.2	
WM90WN-532M16R-04	5	32	30	40	M16	4.0	0.3	
WM90WN-632M16R-04	6	32	30	40	M16	4.0	0.3	

STANDARD CUTTER WITHOUT INTERNAL COOLANT

INSERTS TO BE ORDERED SEPARATELY

ACCESSORY

MODEL	SCREW	WRENCH
WM90WN	M 2565-P	G 08W-P

ANSERIES: HW90AN-M



Threaded end mill shank, $Kr=90^\circ$

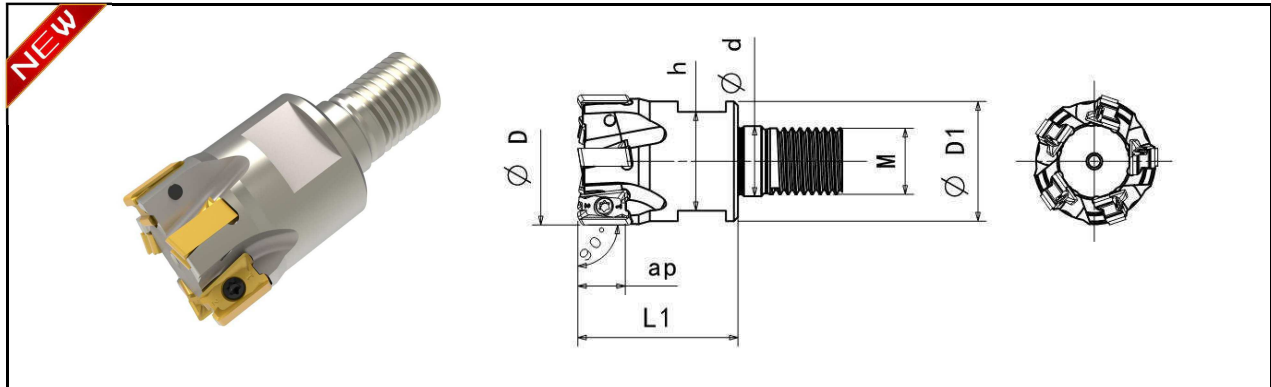

MODEL		DIMENSION							SUITABLE INSERT
		D	D1	d	M	L1	h	ap	
HW90AN-220M10R-12	2	20	18	10.5	M10	28	15	11.5	ANMU 1204
HW90AN-325M12R-12	3	25	21	12.5	M12	40	17		
HW90AN-432M16R-12	4	32	29	17.0	M16	40	24		
HW90AN-532M16R-12	5	32	29	17.0	M16	40	24		
HW90AN-225M12R-17	2	25	21	12.5	M12	32	17	16.5	ANMU 17T6 ANMU 17T6
HW90AN-332M16R-17	3	32	29	17.0	M16	40	24		
HW90AN-432M16R-17	4	32	29	17.0	M16	40	24		
HW90AN-435M16R-17	4	35	29	17.0	M16	40	24		
HW90AN-540M16R-17	5	40	29	17.0	M16	40	24		

STANDARD CUTTER WITHOUT INTERNAL COOLANT

INSERTS TO BE ORDERED SEPARATELY

ACCESSORY

MODEL	DIA	SCREW	WRENCH
HW90AN-**-12	20 25 32 40	M. 3080	G 10W
HW90AN-**-17	25 32	M. 4010	G 15W
HW90AN-**-17	40	M. 4013	G 15W

ANSERIES: HW90AN-Y



END MILL CUTTER, Kr=90°

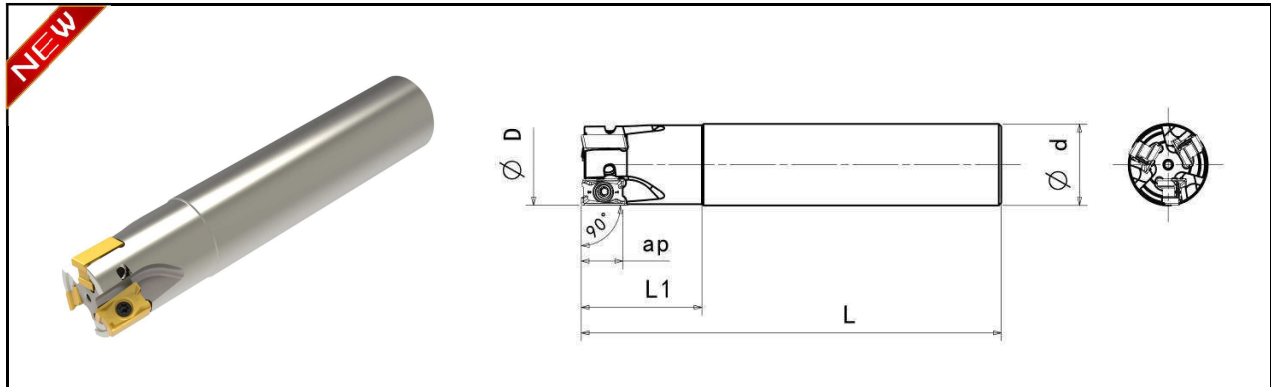

MODEL	KR		DIMENSION					Kg	SUITABLE INSERT
			D	d	L	L1	ap		
HW90AN-220L150Y20R-12	90°	2	20	20	150	28	11.5	0.33	ANMU 1204
HW90AN-320L90Y20R-12		3	20	20	90	28		0.21	
HW90AN-320L150Y20R-12		3	20	20	150	28		0.33	
HW90AN-325L170Y25R-12		3	25	25	170	43		0.63	
HW90AN-425L100Y25R-12		4	25	25	100	43		0.33	
HW90AN-425L170Y25R-12		4	25	25	170	43		0.59	
HW90AN-432L200Y32R-12		4	32	32	200	49		1.16	
HW90AN-532L110Y32R-12		5	32	32	110	49		0.61	
HW90AN-532L200Y32R-12		5	32	32	200	49		1.17	
HW90AN-540L200Y32R-12		5	40	32	200	49		1.22	
HW90AN-225L100Y25R-17		16.5	2	25	25	100	43	0.28	ANMU 17T6 ANMU 17T6
HW90AN-225L170Y25R-17			2	25	25	170	43	0.58	
HW90AN-332L110Y32R-17			3	32	32	110	49	0.58	
HW90AN-332L200Y32R-17			3	32	32	200	50	1.14	
HW90AN-432L110Y32R-17			4	32	32	110	49	0.58	
HW90AN-432L200Y32R-17			4	32	32	200	50	1.14	
HW90AN-340L200Y32R-17			3	40	32	200	50	1.21	
HW90AN-440L200Y32R-17	4		40	32	200	50	1.20		

STANDARD CUTTER WITHOUT INTERNAL COOLANT

INSERTS TO BE ORDERED SEPARATELY

AN



INSERTS

AN INSERTS

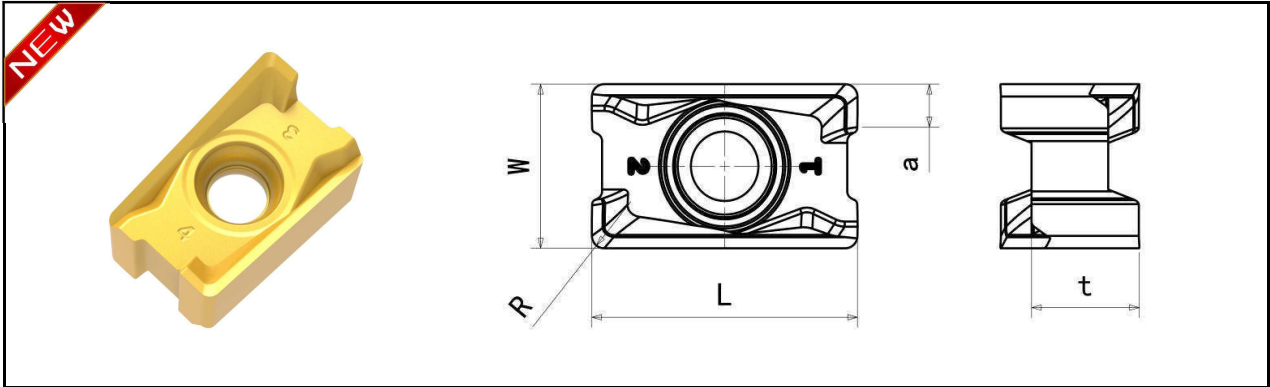

MODEL	EDGE LEONG	KR	DIMENSION					GRADE				
			L	W	t	a	R	HW0632	HW1804	HW1814	HW8320	HW7519
ANMU 120404PFR-M	12	90°	12.55	7.0	4.84	1.7	0.4	●	●		●	
ANMU 120404PFR-M							0.4					
ANMU 120408PFR-M							0.8					
ANMU 120408PER-MM							0.8					
ANMU 120412PFR-M							1.2					
ANMU 17T608PFR-M	17	90°	17.3	10.4	7.03	2.7	0.8	●	●		●	
ANMU 17T608PER-MM							0.8					
ANMU 17T608PER-MM							0.8					
ANMU 17T608PER-M							0.8					
ANMU 17T608PER-SM							0.8					
ANMU 17T616PFR-M							1.6					



ACCESSORY

MODEL	DIA	SCREW	WRENCH
HW90AN-**-12	20 25 32 40	M. 3080	G 10W
HW90AN-**-17	25 32	M. 4010	G 15W
HW90AN-**-17	40	M. 4013	G. 15W

HWM...SP



Chamfering Mill Holder

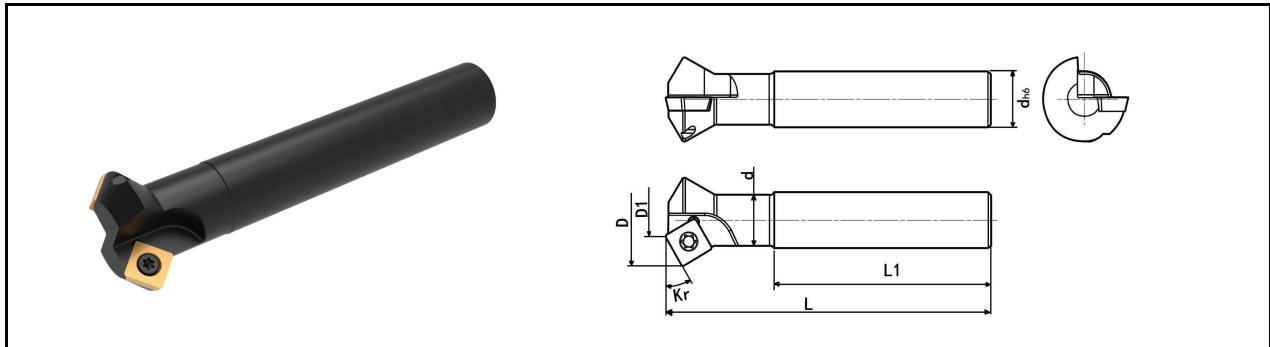

MODEL	Kr (°)		DIMENSION						INSERT
			D	D1	d1	d	L	L1	
HWM30SP-112L120Y20R-12	30	1	32.4	11.6	18	20	120	80	SPKT. 1204
HWM45SP-112L120Y20R-12	45	1	28.6	11.35	18	20	120	80	
HWM45SP-225L160Y25R-12	45	2	41.66	24.34	24.4	25	160	120	
HWM60SP-225L160Y25R-12	60	2	36.78	24.48	24.4	25	160	120	

STANDARD. CUTTER HOLDER WITHOUT INTERNAL COOLANT, INSERTS TO BE ORDERED SEPARATELY

INSERTS

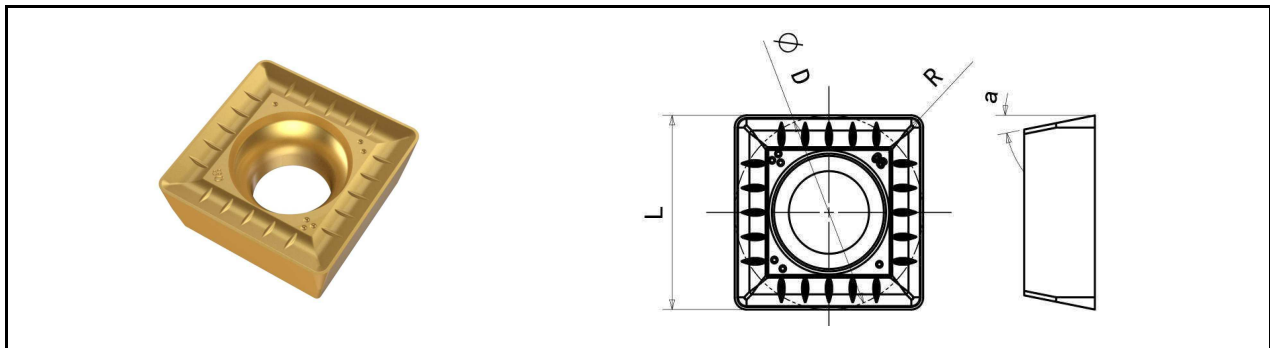

MODEL	DIMENSION				GRADE			
	d	t	a	r	HW0632	HW1804	HW8420	HW7519
SPKT 120408-M	12.7	4.76	11°	0.8			●	

ACCESSORY

MODEL	SCREW	WRENCH
	HWM...SP	M 5012

HWM...TC



Chamfering Mill Holder

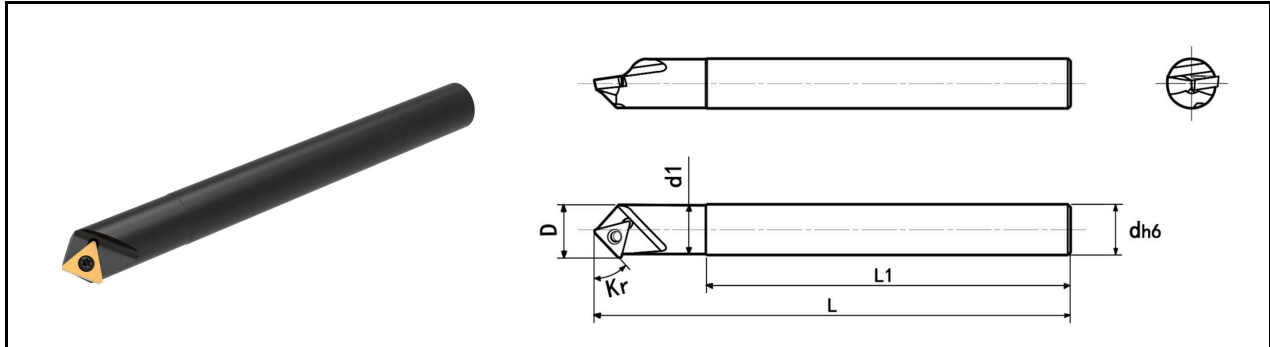

MODEL	Kr (°)		MIN DIA	DIMENSION					INSERT
				D	d1	d	L	L1	
HWM45TC-D4RY16R-11 45		1	4	16	15.5	16	130	100	TCMT 1102
HWM45TC-D6RY20R-16	45	1	6	23.3	19.6	20	200	150	TCMT 16T3

STANDARD CUTTER HOLDER WITHOUT INTERNAL COOLANT

INSERTS TO BE ORDERED SEPARATELY

TCMT INSERTS

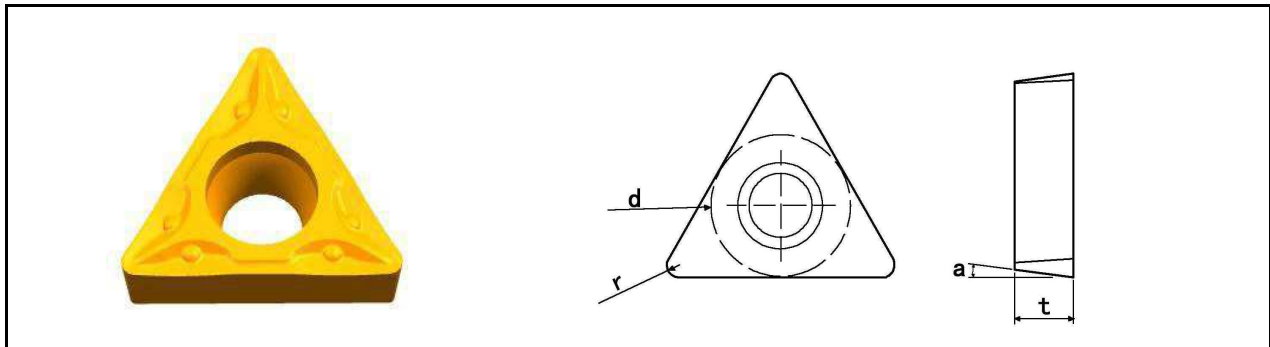

MODEL	DIMENSION				GRADE			
	d	t	a	r	HW0632	HW1804	HW8330	HW7519
TCMT 110204	6.35	2.38	7°	0.4	•	•	•	•
TCMT 16T308	9.52	3.97	7°	0.8	•	•	•	•

ACCESSORY

MODEL	INSERT SCREW	WRENCH
	HWM...TC...11	M2560
HWM...TC...16	M4090	G15W

HWM...XC



Chamfering Mill Holder

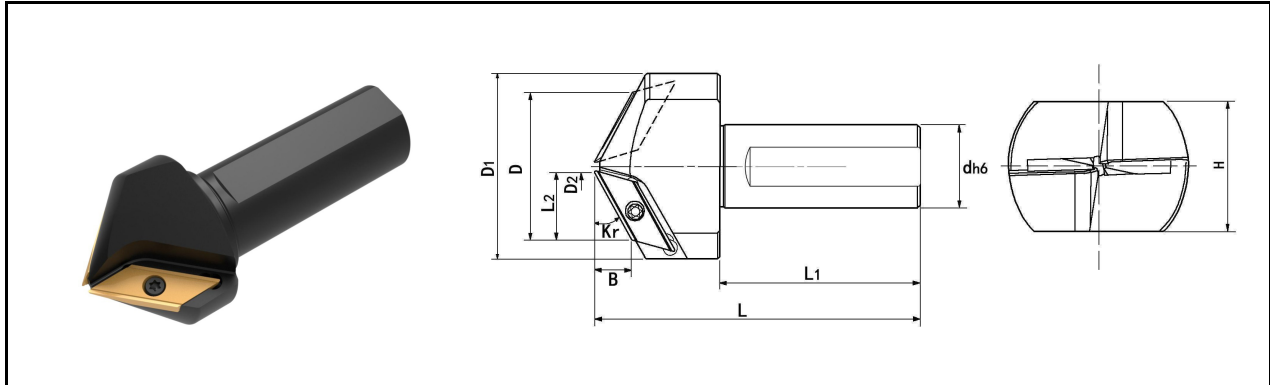

MODEL		DIMENSION									
		Kr	B	L2	D	D1	D2	L	L1	d	H
HWM60XC-134L130W32R-31	1	60	25.5	14.5	34	40	5	130	80	32	—
HWM45XC-246L130W32R-31	2	45	20.5	20.5	46	56	5	130	80	32	45
HWM30XC-255L130W32R-31	2	30	14.5	25.5	55	72	5	130	80	32	50

©STANDARD CUTTER WITHOUT INTERNAL COOLANT INSERTS TO BE ORDERED SEPARATELY

©MTN DIA ϕ 5mm

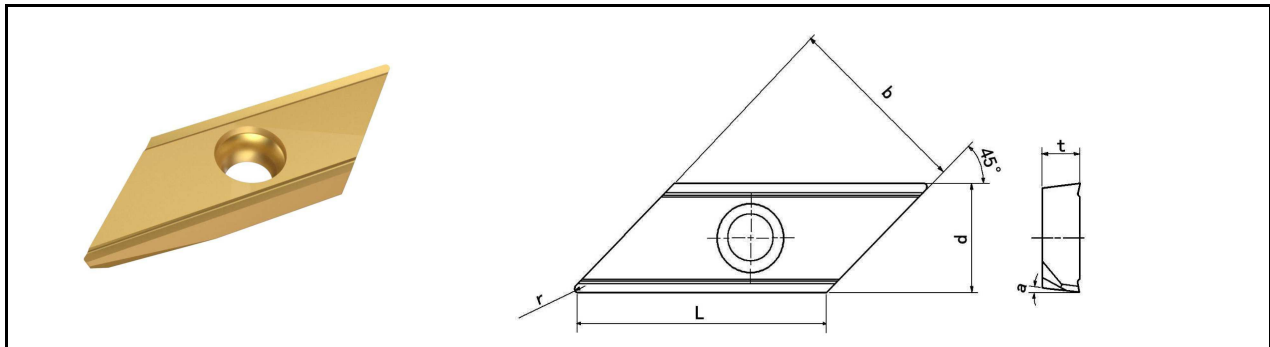

MODEL	EDGE LENGTH	DIMENSION						GRADE			
		L	b	d	t	a	r	HW0632	HW0622	HW1804	HW1814
XCET 310404	31	29.2	22	12.7	4.5	7°	0.4	●			

ACCESSORY

MODEL	INSERT SCREW	WRENCH
	HWM60XC-134L130W32R-31	
HWM45XC-246L130W32R-31	M5012	G20W
HWM30XC-255L130W32R-31		

AP17Corn TYPE milling series: HWM90AP



Corn TYPE milling cutter HOLDER

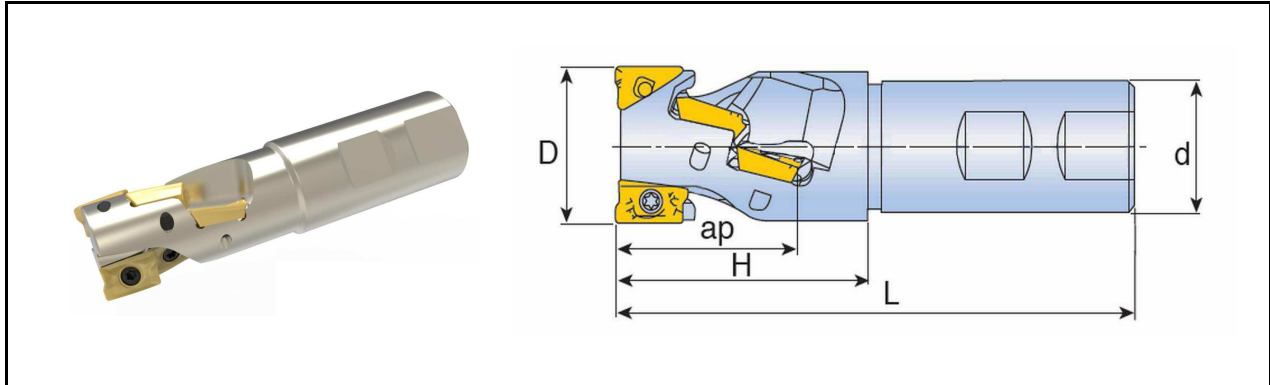

MODEL		TEETH	DIMENSION					INSERT
			D	d	H	L	ap	
HWM90AP-2232L120Z32-17	2	4	32	32	50	120	30	APKT. 1705
HWM90AP-2340L140Z32-17	2	6	40	32	65	140	44	

STANDARD. CUTTER WITHOUT. INTERNAL COOLANT

INSERTS. TO. BE. ORDERED. SEPARATELY

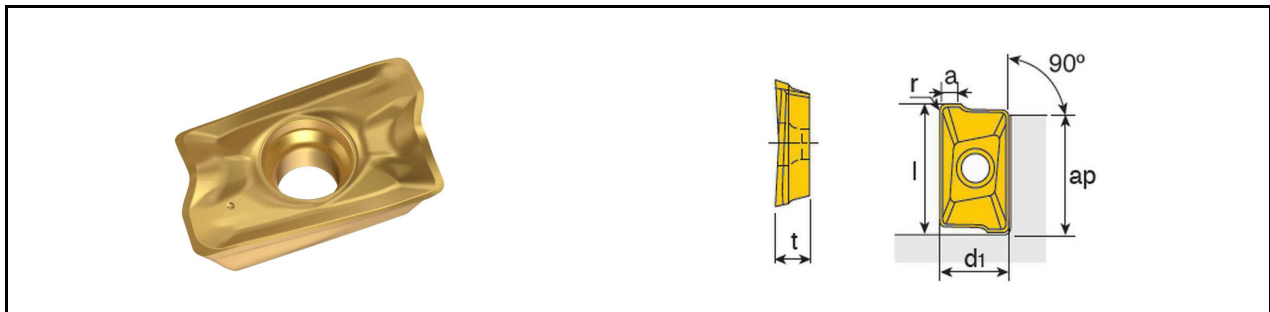

MODEL	EDGE LENGTH	DIMENSION						GRADE			
		d	ap	L	t	a	r	HW0632	HW1814	HW8320	HW7519
APKT 1705PER-M	17	10.7	16.1	18.5	5.56	3.0	0.8	●	●		

ACCESSORY	MODEL	SCREW	WRENCH
	HWM90AP	M 4090	G. 15W

AP17Corn TYPE milling series: HWM90AP



Corn milling cutter HOLDER

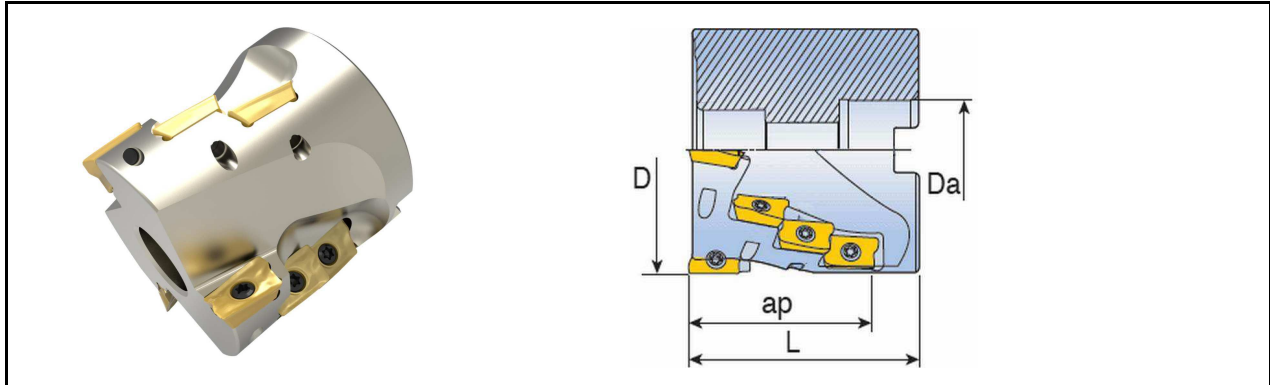

MODEL		TEETH	DIMENSION				CONNE CTOR		INSERT
			D	L	ap	Da			
HWM90AP-2350H44A22R-17	2	6	50	60	44	22	Λ	0.5	APKT. 1705
HWM90AP-3363H44A27R-17	3	9	63	63	44	27	A	0.9	
HWM90AP-4363H44A27R-17	4	12	63	63	44	27	A	0.9	
HWM90AP-4480H58A32R-17	4	16	80	75	58	32	A	1.9	
HWM90AP-56100H88A40R-17	5	30	100	110	88	40	A	4.8	

©STANDARD. CUTTER WITHOUT. INTERNAL. COOLANT

©INSERTS TO BE ORDERED SEPARATELY



MODEL	EDGE LENGTH	DIMENSION						GRADE			
		d	ap	L	t	a	r	HW0632	HW1814	HW8320	HW7519
APKT 1705PER-EM	17	10.7	16.1	18.5	5.56	3.0	0.8	●	●		

ACCESSORY	MODEL	SCREW	WRENCH
	HWM90AP	M. 4090	G. 15W

ENCorn TYPE milling series: HWM90CN-H



CHANGABLE Corn milling cutter HOLDER

©Different interface tool holders can be selected BT/SK/HSK

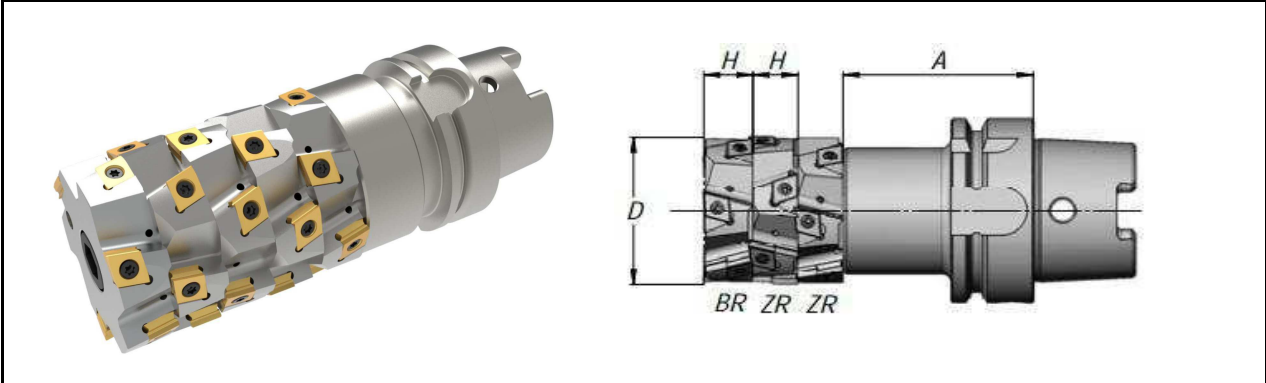

D	B R				Z R				INSERT
	MODEL		TEETH	H	MODEL		TEETH	H	
50	HWM90CN-650BR25-M09	3	6	17.1	HWM90CN-650ZR25-M09	3	6	16	CNGX 0904
63	HWM90CN-663BR25-M09	3	6	17.1	HWM90CN-663ZR25-M09	3	6	16	
80	HWM90CN-680BR32-M12	3	6	23.2	HWM90CN-680ZR32-M12	3	6	22	CNGX 1206
100	HWM90CN-8100BR32-M12	4	8	23.2	HWM90CN-8100ZR32-M12	4	8	22	

©Standard shank with internal coolant, INSERTS TO BE ORDERED SEPARATELY

©See page C69 for adapting standard toolholders, HOLDER CUSTOMIZED

©this shank requires a left-hand blade and a right-hand blade

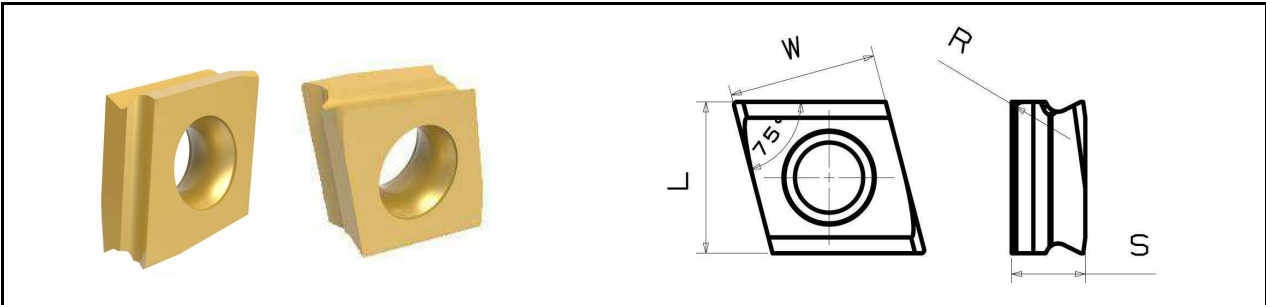
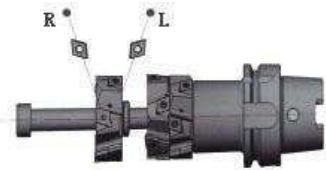

MODEL	GRADE	MODEL	GRADE	EDGE LONG	DIMENSION			ACCESSORY	
	HW 0622		HW A7		S	L=W	R	SCREW	WRENCH
CNGX 090406R	●	CNGX 090406R-AL	●	09	4.76	9.525	0.6	M 4090	G 15W
CNGX 090406L	●	CNGX 090406L-AL	●				0.6		
CNGX 090408R	●	CNGX 090408R-AL	●				0.8		
CNGX 090408L	●	CNGX 090408L-AL	●				0.8		
CNGX 120608R	●	CNGX 120608R-AL	●	12	6.35	12.7	0.8	M 5016	G 20W
CNGX 120608L	●	CNGX 120608L-AL	●				0.8		
CNGX 120610R	●	CNGX 120610R-AL	●				1.0		
CNGX 120610L	●	CNGX 120610L-AL	●				1.0		

ENCorn TYPE milling series: HWM90CN-H



CHANGABLE Corn milling cutter HOLDER

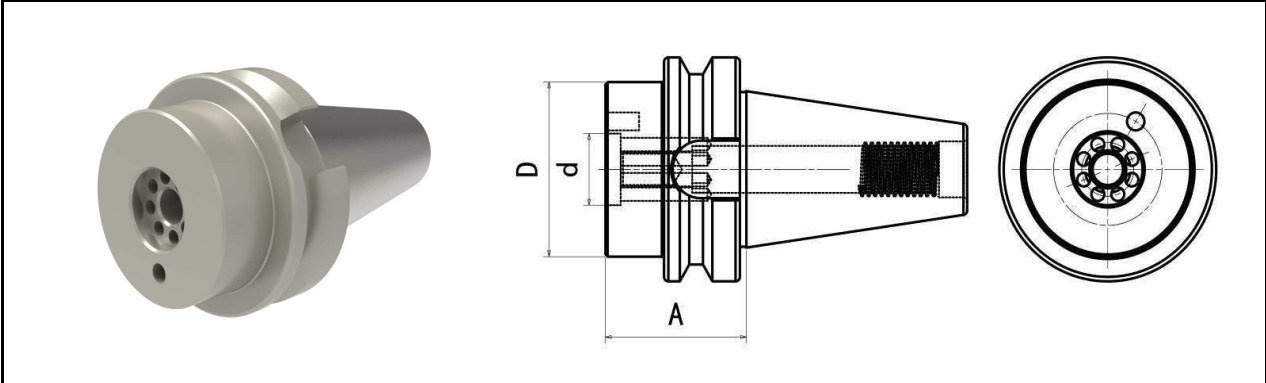

MODEL	SHANK TYPE	DIMENSION			MODEL	Shank Type	DIMENSION		
		D	A	d			D	A	d
BT40-D2512-L50	BT40	58	50	25	BT50-D2512-L65	BT50	58	65	25
BT40-D2512-L75	BT40	58	75	25	BT50-D2512-L90	BT50	58	90	25
BT40-D2512-L100	BT40	58	100	25	BT50-D2512-L110	BT50	58	110	25
BT40-D3216-L50	BT40	75	50	32	BT50-D3216-L65	BT50	75	65	32
BT40-D3216-L75	BT40	75	75	32	BT50-D3216-L90	BT50	75	90	32
BT40-D3216-L100	BT40	75	100	32	BT50-D3216-L110	BT50	75	110	32

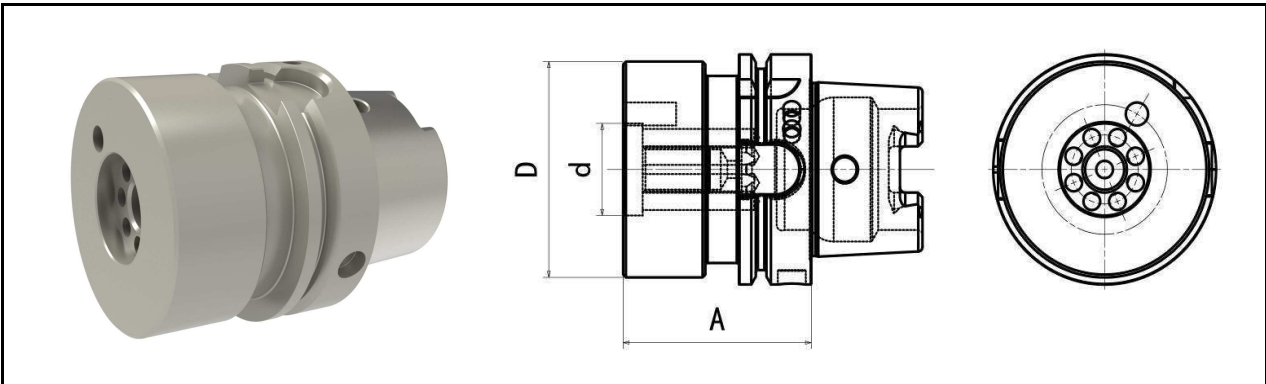

MODEL	Shank Type	DIMENSION			MODEL	Shank Type	DIMENSION		
		D	A	d			D	A	d
HSK63-D2512-L70	HSK63	58	70	25	HSK100-D2512-L70	HSK100	58	70	25
HSK63-D2512-L110	HSK63	58	110	25	HSK100-D2512-L110	HSK100	58	110	25
HSK63-D2512-L130	HSK63	58	130	25	HSK100-D2512-L130	HSK100	58	130	25
HSK63-D3212-L70	HSK63	75	70	32	HSK100-D3212-L70	HSK100	75	70	32
HSK63-D3212-L110	HSK63	75	110	32	HSK100-D3212-L110	HSK100	75	110	32
HSK63-D3212-L130	HSK63	75	130	32	HSK100-D3212-L130	HSK100	75	130	32

3KGF Shallow groove milling cutter shank SERIES: HW3KGF



Shallow groove milling cutter shank

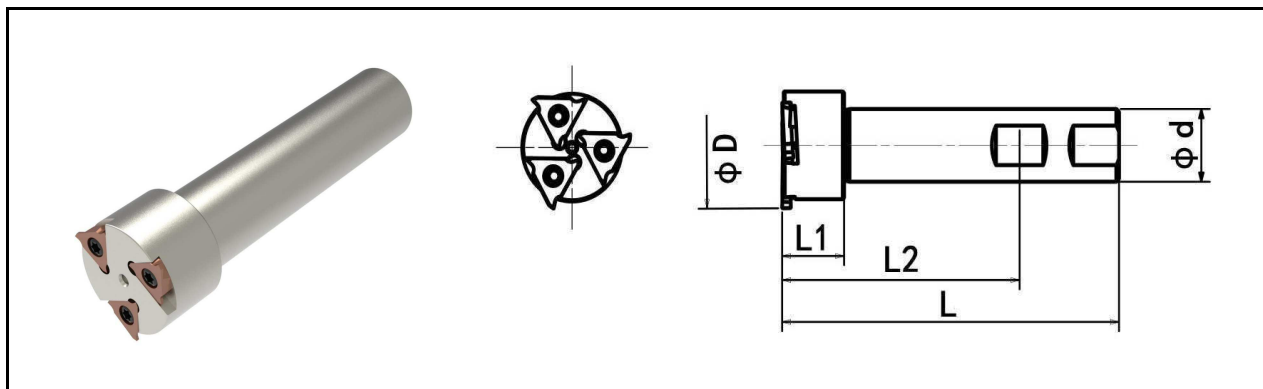

MODEL		DIMENSION MM					Grooving width (mm)	INSERTS
		D	d	L1	L2	L		
HW3KGF -125L125Z25R-16	1	25	25	40	93	125	1.10~3.00	3KGF. 16L110~300
HW3KGF -339L125Z25R-16	3	39	25	23	93	125	1.10~3.00	
HW3KGF -344L125Z25R-22	3	44	25	23	93	125	1.25~4.80	3KGF. 22L125~480

◎STANDARD. CUTTER WITHOUT INTERNAL COOLANT

◎INSERTS to be ordered separately

◎Note that right-hand shanks are paired with left-hand blades

◎WIDE RANGE: 1.1~4.8 mm

◎MAX DEPTH: 5.0 mm

◎Wide range of blade widths, suitable for all kinds of shallow grooves and spring grooves

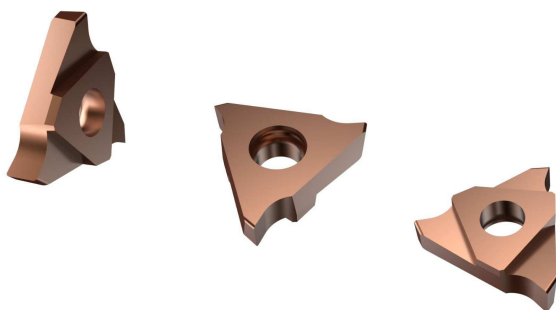

ACCESSORY

MODEL	SCREWS	WRENCH
HW3KGF -16	M 4013-P	G 15W-P
HW3KGF -22	M 5016	G 20W

3KGF Shallow groove milling cutter shank SERIES: HWM3KGF



Shallow groove milling cutter HOLDER

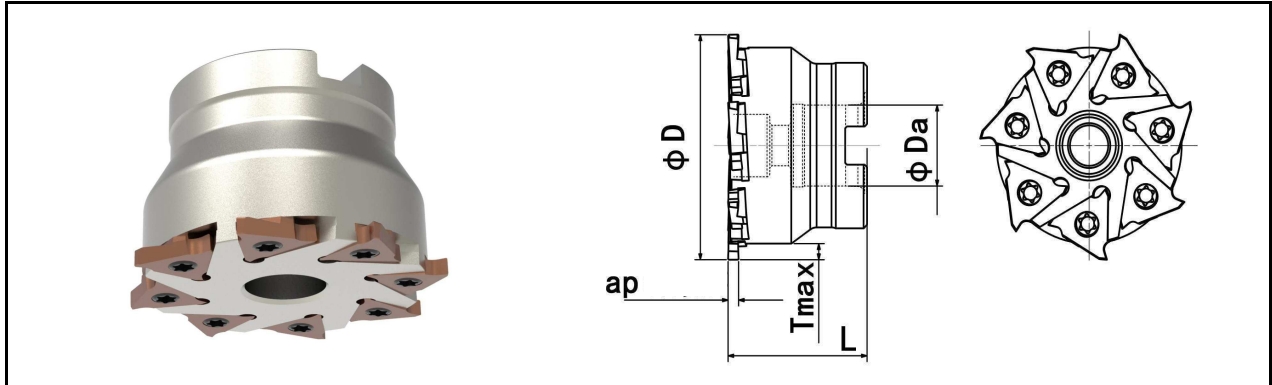

MODEL		DIMENSION MM				LEFT/ RIGHT	CONNE CTOR	INSERTS	
		D	Da	L	ap				
HWM3KGF -763A22R-16	7	63	22	40	1.10~3.00	RIGHT HAND	A	3KGF. 16L110~300	
HWM3KGF -980A27R-16	9	80	27	50					
HWM3KGF -11100B32R-16	11	100	32	50					
HWM3KGF -13125B40R-16	13	125	40	63		LEFT HAND	B		3KGF. 16R110~300
HWM3KGF -763A22L-16	7	63	22	40					
HWM3KGF -980A27L-16	9	80	27	50					
HWM3KGF -11100B32L-16	11	100	32	50	1.25~4.80	RIGHT HAND	A	3KGF. 22L125~480	
HWM3KGF -13125B40L-16	13	125	40	63					
HWM3KGF -663A22R-22	6	63	22	40					
HWM3KGF -880A27R-22	8	80	27	50		LEFT HAND	B		3KGF. 22R125~480
HWM3KGF -10100B32R-22	10	100	32	50					
HWM3KGF -12125B40R-22	12	125	40	63					
HWM3KGF -663A22L-22	6	63	22	40	1.25~4.80	RIGHT HAND	A	3KGF. 22L125~480	
HWM3KGF -880A27L-22	8	80	27	50					
HWM3KGF -10100B32L-22	10	100	32	50					
HWM3KGF -12125B40L-22	12	125	40	63		LEFT HAND	B		3KGF. 22R125~480
HWM3KGF -663A22R-22	6	63	22	40					
HWM3KGF -880A27R-22	8	80	27	50					

©STANDARD CUTTER WITHOUT INTERNAL COOLANT, INSERTS TO BE ORDERED SEPARATELY

©RIGHT HAND CUTTER HOLDER COMPATIBLE WITH LEFT INERTS, LEFT HANDCUTTER WITH RIGHT INSERTS.

ACCESSORY

MODEL	SCREWS	WRENCH
HW3KGF -16	M 4013-P	G 15W-P
HW3KGF -22	M 5016	G 20W

3KGF



INSERTS

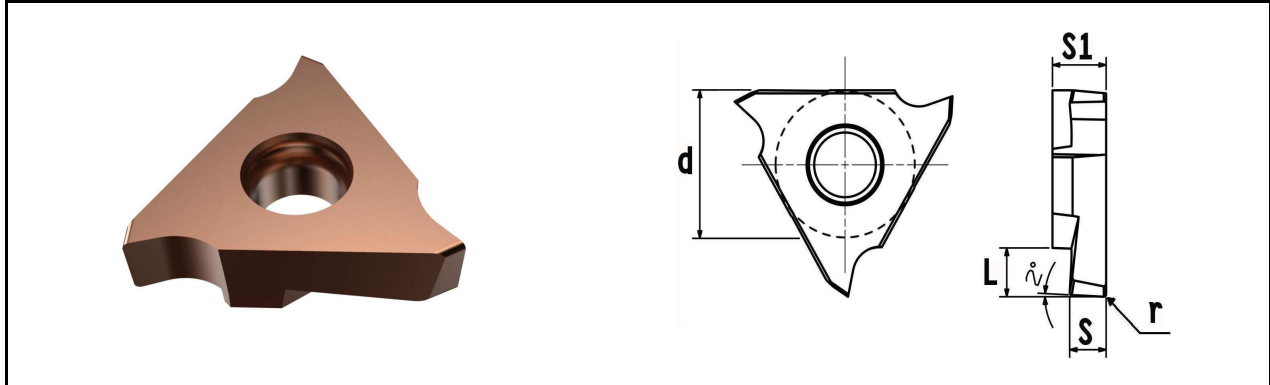

MODEL	DIMENSION MM					GRADE
	S	L	ød	S1	r	HW 0612
3KGF 16L110-R01	1.10	2.0	9.525	3.18	0.1	●
3KGF 16L125-R02	1.25	2.0	9.525	3.18	0.2	●
3KGF 16L145-R02	1.45	2.0	9.525	3.18	0.2	●
3KGF 16L150-R02	1.50	2.0	9.525	3.18	0.2	●
3KGF 16L175-R02	1.75	2.0	9.525	3.18	0.2	●
3KGF 16L185-R02	1.85	2.5	9.525	3.18	0.2	●
3KGF 16L200-R02	2.00	2.5	9.525	3.18	0.2	●
3KGF 16L250-R02	2.50	2.5	9.525	3.18	0.2	●
3KGF 16L300-R02	3.00	3.0	9.525	3.18	0.2	●
3KGF 22L125-R02	1.25	2.0	12.7	3.18	0.2	●
3KGF 22L145-R02	1.45	2.0	12.7	3.18	0.2	●
3KGF 22L150-R02	1.50	3.5	12.7	4.76	0.2	●
3KGF 22L175-R02	1.75	3.5	12.7	4.76	0.2	●
3KGF 22L185-R02	1.85	3.5	12.7	4.76	0.2	●
3KGF 22L200-R02	2.00	3.5	12.7	4.76	0.2	●
3KGF 22L230-R02	2.30	3.5	12.7	4.76	0.2	●
3KGF 22L250-R03	2.50	4.0	12.7	4.76	0.3	●
3KGF 22L265-R03	2.65	4.0	12.7	4.76	0.3	●
3KGF 22L280-R03	2.80	4.0	12.7	4.76	0.3	●
3KGF 22L300-R03	3.00	4.0	12.7	4.76	0.3	●
3KGF 22L320-R03	3.20	4.0	12.7	4.76	0.3	●
3KGF 22L330-R03	3.30	4.0	12.7	4.76	0.3	●
3KGF 22L350-R03	3.50	5.0	12.7	4.76	0.3	●
3KGF 22L400-R04	4.0	5.0	12.7	4.76	0.4	●
3KGF 22L430-R04	4.3	5.0	12.7	4.76	0.4	●
3KGF 22L450-R04	4.5	5.0	12.7	4.76	0.4	●
3KGF 22L480-R04	4.8	5.0	12.7	5.06	0.4	●

ZNV Vertical three-sided INSERT series: HWMZN...R



Three-sided edge milling cutter: Fixed flange type

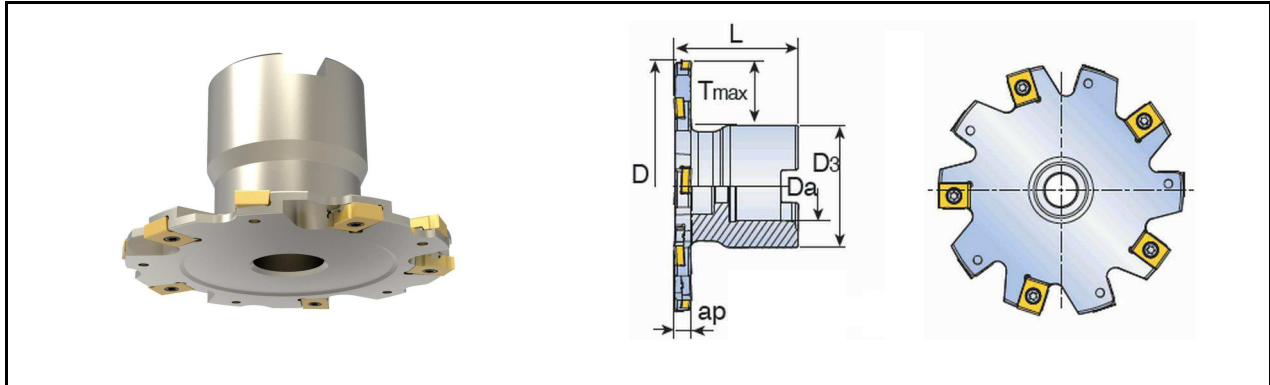

MODEL		ap (mm)	DIMENSION MM					CONNE CTOR	 Kg	INSERTS
			D	Da	D3	L	Tmax			
HWMZN-1080W04A22R-Z23	5+5	4	80	22	40	50	20.0	A	0.4	ZNMT. 023
HWMZN-12100W04A27R-Z23	6+6	4	100	27	48	50	26.0	A	0.6	
HWMZN-1080W05A22R-Z28	5+5	5	80	22	40	50	20.0	A	0.5	ZNMT. 028
HWMZN-12100W05A27R-Z28	6+6	5	100	27	48	50	26.0	A	0.7	
HWMZN-1080W06A22R-Z33	5+5	6	80	22	40	50	20.0	A	0.6	ZNMT. 033
HWMZN-12100W06A27R-Z33	6+6	6	100	27	48	50	26.0	A	0.7	
HWMZN-14125W06B40R-Z33	7+7	6	125	40	70	50	25.0	B	1.2	
HWMZN-18160W06B40R-Z33	9+9	6	160	40	70	50	43.0	B	1.5	

©STANDARD. CUTTER WITHOUT. J

©INSERTS. TO. BE. ORDERED. SEPARATELY

ACCESSORY

MODEL	SCREWS	WRENCH
HWMZN-023	M 2531	G. 08W
HWMZN-028	M 2542	G. 08W
HWMZN-033	M 2553	G. 08W

ZN VERTICAL 3 SIDED INSERT BLADE CUTTER SERIES: HWMZN...R



Three-sided milling cutter head: fixed flange type

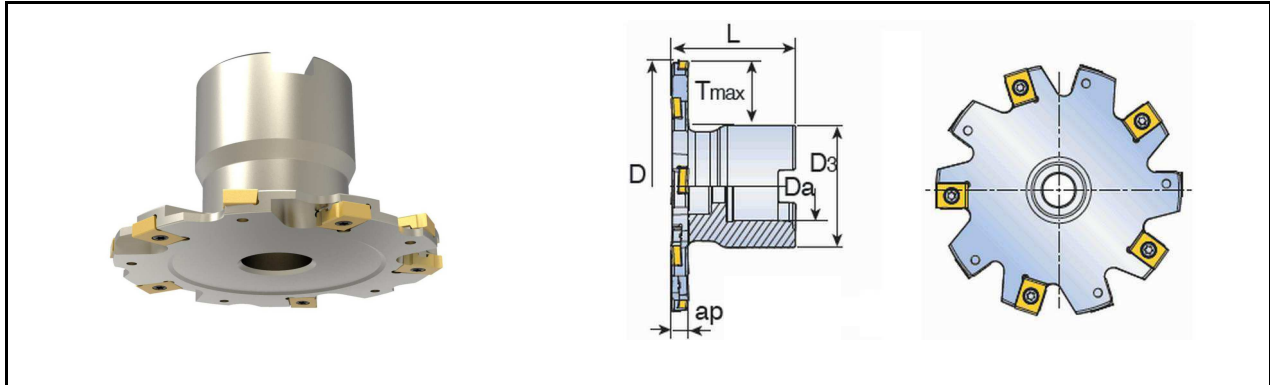

MODEL		ap (mm)	DIMENSION MM					CONNE CTOR	 Kg	INSERTS
			D	Da	D3	L	Tmax			
HWMZN-880W07A22R-Z38	4+4	7	80	22	40	50	20.0	A	0.5	ZNMT. 038
HWMZN-10100W07A27R-Z38	5+5	7	100	27	48	50	25.5	A	0.7	
HWMZN-12125W07B40R-Z38	6+6	7	125	40	70	50	24.5	B	1.2	
HWMZN-16160W07B40R-Z38	8+8	7	160	40	70	50	42.0	B	1.5	
HWMZN-880W08A22R-Z43	4+4	8	80	22	40	50	20.0	A	0.5	ZNMT. 043
HWMZN-10100W08A27R-Z43	5+5	8	100	27	48	50	25.5	A	0.8	
HWMZN-12125W08B40R-Z43	6+6	8	125	40	70	50	24.5	B	1.2	
HWMZN-16160W08B40R-Z43	8+8	8	160	40	70	50	42.0	B	1.6	
HWMZN-10100W09A27R-Z48	5+5	9	100	27	48	50	26.0	A	0.8	ZNMT. 048
HWMZN-12125W09B40R-Z48	6+6	9	125	40	70	50	24.5	B	1.3	
HWMZN-16160W09B40R-Z48	8+8	9	160	40	70	50	42.0	B	1.7	
HWMZN-10100W10A27R-Z53	5+5	10	100	27	48	50	26.0	A	0.8	ZNMT. 053
HWMZN-12125W10B40R-Z53	6+6	10	125	40	70	50	24.5	B	1.4	
HWMZN-16160W10B40R-Z53	8+8	10	160	40	70	50	42.0	B	1.9	

©STANDARD. CUTTER WITHOUT]

© INSERTS. TO. BE. ORDERED. SEP

ACCESSORY

MODEL	SCREWS	WRENCH	MODEL	SCREWS	WRENCH
HWMZN-038	M 4051	G 15W	HWMZN-048	M 4070	G 15W
HWMZN-043	M 4061	G 15W	HWMZN-053	M 4080	G 15W

ZN VERTICAL 3 SIDED INSERT BLADE CUTTER SERIES: HWMZN...R



THREE SIDED EDGE MILL CUTTER:FIXED FLANGE TYPE

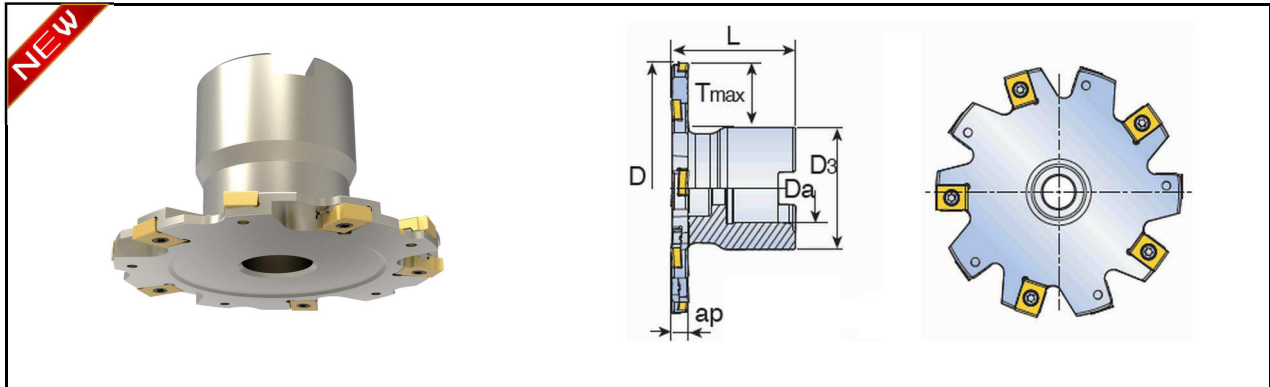

MODEL		ap (mm)	DIMENSION MM					CONNE CTOR		INSERTS
			D	Da	D3	L	Tmax			
HWMZN-8100W11A27R-Z58	4+4	11	100	27	48	50	26.0	A	0.8	ZNMT_058
HWMZN-10125W11B40R-Z58	5+5	11	125	40	70	50	24.5	B	1.4	
HWMZN-14160W11B40R-Z58	7+7	11	160	40	70	50	42.0	B	1.9	
HWMZN-8100W12A27R-Z63	4+4	12	100	27	48	50	26.0	A	0.8	ZNMT_063
HWMZN-10125W12B40R-Z63	5+5	12	125	40	70	50	24.5	B	1.4	
HWMZN-14160W12B40R-Z63	7+7	12	160	40	70	50	42.0	B	1.9	
HWMZN-8100W13A27R-Z68	4+4	13	100	27	48	50	26.0	A	0.8	ZNMT_068
HWMZN-10125W13B40R-Z68	5+5	13	125	40	70	50	24.5	B	1.4	
HWMZN-14160W13B40R-Z68	7+7	13	160	40	70	50	42.0	B	1.9	
HWMZN-8100W14A27R-Z73	4+4	14	100	27	48	50	26.0	A	0.8	ZNMT_073
HWMZN-10125W14B40R-Z73	5+5	14	125	40	70	50	24.5	B	1.4	
HWMZN-14160W14B40R-Z73	7+7	14	160	40	70	50	42.0	B	1.9	

©STANDARD CUTTER WITHOUT INTERNAL COOLANT

©INSERTS TO BE ORDERED SEPARATELY

ACCESSORY

MODEL	SCREWS	WRENCH	MODEL	SCREWS	WRENCH
HWMZN-Z58	M 5012	G 20W	HWMZN-Z68	M 5012	G 20W
HWMZN-Z63	M 5012	G 20W	HWMZN-Z73	M 5012	G 20W

ZNMT



INSERTS

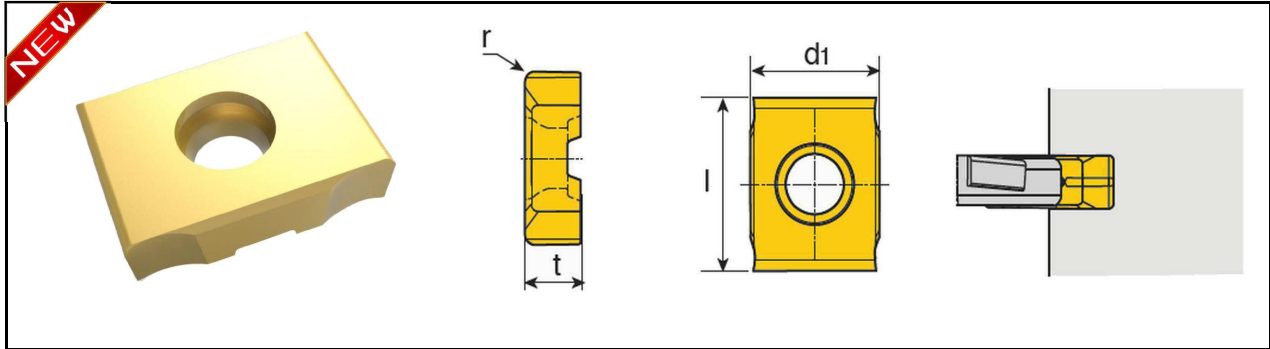

MODEL	EDGE LONG	DIMENSION MM				Feed	GRADE
		l	d1	t	r	(mm/tooth)	HW 0632
ZNMT 023-04-ML	023	10	7.5	2.3	0.4	0.05~0.08	●
ZNMT 028-04-ML	028	10	7.5	2.8	0.4	0.05~0.08	●
ZNMT 033-04-ML	033	10	7.5	3.3	0.4	0.05~0.12	●
ZNMT 038-04-ML	038	13	10	3.8	0.4	0.05~0.12	●
ZNMT 043-04-ML	043	13	10	4.3	0.4	0.05~0.12	●
ZNMT 043-08-ML	043	13	10	4.3	0.8	0.05~0.12	●
ZNMT 048-04-ML	048	13	10	4.8	0.4	0.05~0.12	●
ZNMT 048-08-ML	048	13	10	4.8	0.8	0.05~0.12	●
ZNMT 053-04-ML	053	13	10	5.3	0.4	0.05~0.12	●
ZNMT 053-08-ML	053	13	10	5.3	0.8	0.05~0.12	●
ZNMT 058-04-ML	058	15	12	5.8	0.4	0.05~0.12	●
ZNMT 058-08-ML	058	15	12	5.8	0.8	0.05~0.12	●
ZNMT 063-04-ML	063	15	12	6.3	0.4	0.05~0.12	●
ZNMT 063-08-ML	063	15	12	6.3	0.8	0.05~0.12	●
ZNMT 068-08-ML	068	15	12	6.8	0.8	0.05~0.12	●
ZNMT 068-12-ML	068	15	12	6.8	1.2	0.05~0.12	●
ZNMT 073-08-ML	073	15	12	7.3	0.8	0.05~0.12	●
ZNMT 073-12-ML	073	15	12	7.3	1.2	0.05~0.12	●

Bridge structure for stronger clamping force

Positive rake angle makes the cutting flow grid

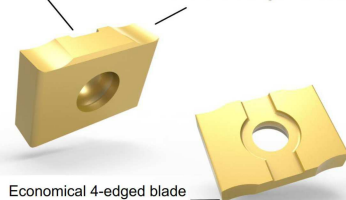

Economical 4-edged blade

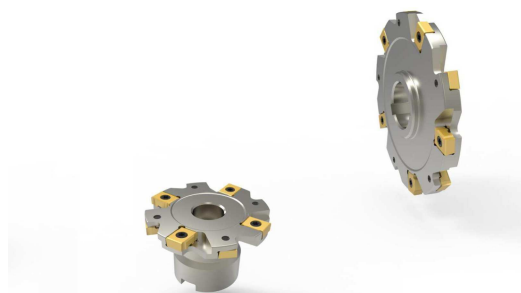

ZN VERTICAL 3 SIDED INSERT BLADE CUTTER SERIES: HWM...H

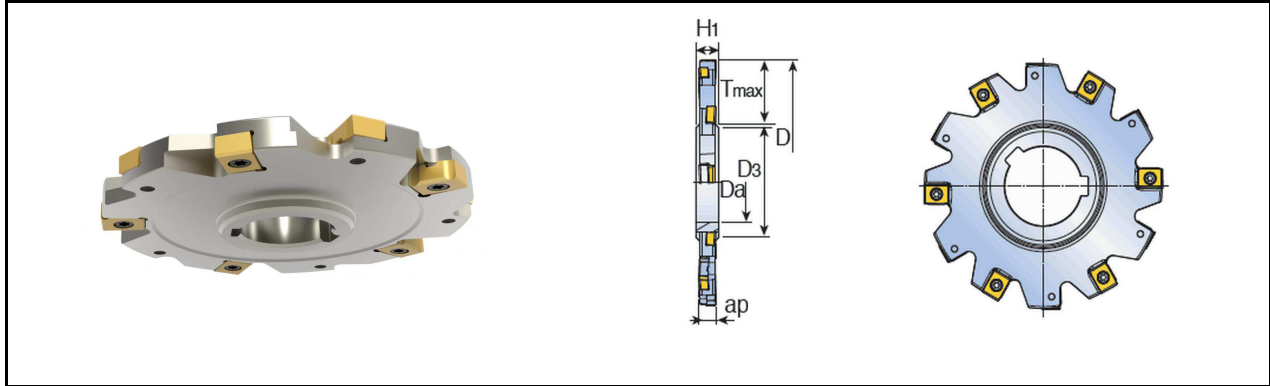

MODEL		ap (mm)	DIMENSION MM						INSERTS
			D	Da	D3	H1	Tmax		
HWMZN-863W04H22-Z23	4+4	4	63	22	34	8	12.0	0.1	ZNMT. 023
HWMZN-1080W04H22-Z23	5+5	4	80	22	34	8	21.0	0.1	
HWMZN-12100W04H27-Z23	6+6	4	100	27	41	12	27.0	0.2	
HWMZN-14125W04H40-Z23	7+7	4	125	40	55	12	32.0	0.4	
HWMZN-863W05H22-Z28	4+4	5	63	22	34	8	13.0	0.1	ZNMT. 028
HWMZN-1080W05H22-Z28	5+5	5	80	22	34	8	21.0	0.2	
HWMZN-12100W05H27-Z28	6+6	5	100	27	41	12	27.0	0.3	
HWMZN-14125W05H40-Z28	7+7	5	125	40	55	12	33.0	0.4	
HWMZN-18160W05H40-Z28	9+9	5	160	40	55	12	50.0	0.7	ZNMT. 033
HWMZN-863W06H22-Z33	4+4	6	63	22	34	8	13.0	0.1	
HWMZN-1080W06H22-Z33	5+5	6	80	22	34	8	21.5	0.2	
HWMZN-12100W06H27-Z33	6+6	6	100	27	41	12	27.0	0.3	
HWMZN-14125W06H40-Z33	7+7	6	125	40	55	12	33.0	0.5	ZNMT. 038
HWMZN-18160W06H40-Z33	9+9	6	160	40	55	12	50.0	0.8	
HWMZN-20200W06H50-Z33	10+10	6	200	50	69	12	63.0	1.2	
HWMZN-880W07H22-Z38	4+4	7	80	22	34	12	20.0	0.2	
HWMZN-10100W07H27-Z38	5+5	7	100	27	41	12	26.5	0.3	ZNMT. 043
HWMZN-12125W07H40-Z38	6+6	7	125	40	55	12	32.0	0.5	
HWMZN-16160W07H40-Z38	8+8	7	160	40	55	12	49.5	0.8	
HWMZN-18200W07H50-Z38	9+9	7	200	50	69	12	62.5	1.3	
HWMZN-24250W07H50-Z38	12+12	7	250	50	69	12	87.5	2.1	ZNMT. 043
HWMZN-880W08H22-Z43	4+4	8	80	22	34	12	20.5	0.2	
HWMZN-10100W08H27-Z43	5+5	8	100	27	41	12	27.0	0.3	

©STANDARD CUTTER WITHOUT INTERNAL COOLANT, INSERTS TO BE ORDERED SEPARATELY

ZN VERTICAL 3 SIDED INSERT BLADE CUTTER SERIES: HWM...H



THREE SIDED EDGE MILL CUTTER: FIXED SINGLE INSERT TYPE

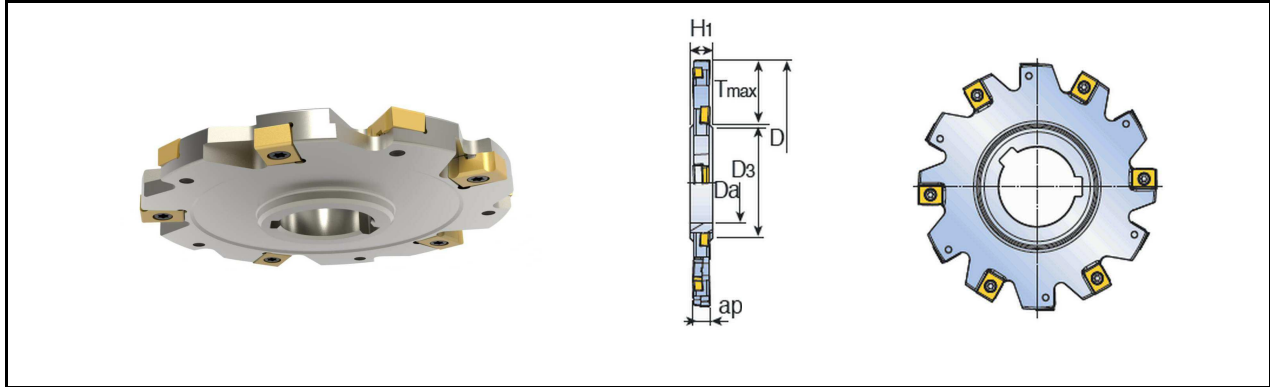

MODEL		ap (mm)	DIMENSION MM						INSERTS
			D	Da	D3	H1	Tmax		
HWMZN-12125W08H40-Z43	6+6	8	125	40	55	12	32.5	0.9	ZNMT. 043
HWMZN-16160W08H40-Z43	8+8	8	160	40	55	12	50.0	0.9	
HWMZN-18200W08H50-Z43	9+9	8	200	50	69	12	63.0	1.4	
HWMZN-24250W08H50-Z43	12+12	8	250	50	69	12	88.0	2.3	
HWMZN-10100W09H27-Z48	5+5	9	100	27	41	12	27.5	0.4	ZNMT. 048
HWMZN-12125W09H40-Z48	6+6	9	125	40	55	12	33.0	0.6	
HWMZN-16160W09H40-Z48	8+8	9	160	40	55	12	50.5	1.0	
HWMZN-18200W09H50-Z48	9+9	9	200	50	69	12	63.5	1.6	
HWMZN-24250W09H50-Z48	12+12	9	250	50	69	12	88.5	2.6	ZNMT. 053
HWMZN-10100W10H27-Z53	5+5	10	100	27	41	12	28.0	0.4	
HWMZN-12125W10H40-Z53	6+6	10	125	40	55	12	33.5	0.6	
HWMZN-16160W10H40-Z53	8+8	10	160	40	55	12	51.0	1.1	
HWMZN-18200W10H50-Z53	9+9	10	200	50	69	12	64.0	1.8	
HWMZN-24250W10H50-Z53	12+12	10	250	50	69	12	89.0	2.9	

©STANDARD. CUTTER WITHOUT. INTERNAL. COOLANT, INSERTS. TO BE ORDERED. SEPARATELY

ACCESSORY

MODEL	SCREWS	WRENCH	MODEL	SCREWS	WRENCH
HWMZN-Z23	M 2531	G 08W	HWMZN-Z38	M 4051	G 15W
HWMZN-Z28	M 2542	G 08W	HWMZN-Z43	M 4061	G 15W
HWMZN-Z33	M 2553	G 08W	HWMZN-Z48	M 4070	G 15W
			HWMZN-Z53	M 4080	G 15W

ZN VERTICAL 3 SIDED INSERT BLADE CUTTER SERIES: HWM...H



THREE SIDED EDGE MILL CUTTER: FIXED SINGLE INSERT TYPE

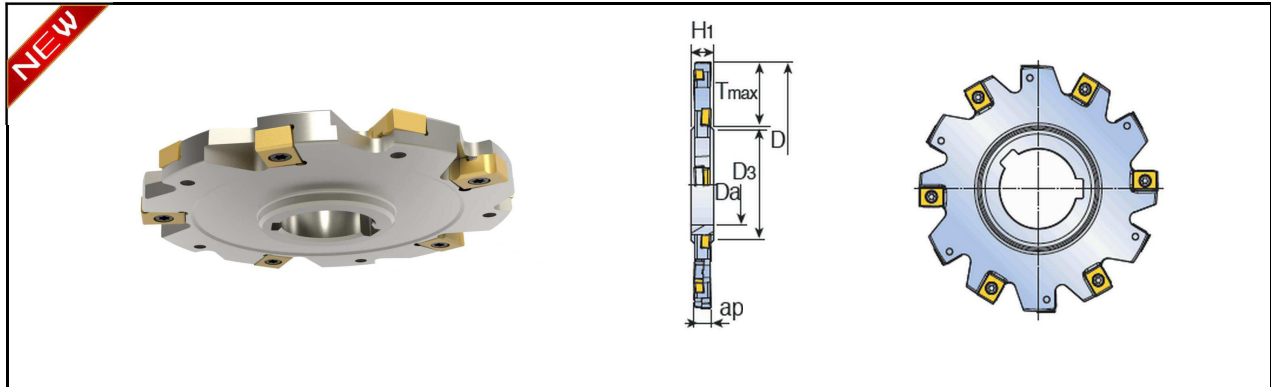

MODEL		ap (mm)	DIMENSION MM						INSERTS
			D	Da	D3	H1	Tmax		
HWMZN-8100W11H27-Z58	4+4	11	100	27	41	16	28.0	0.4	ZNMT_058
HWMZN-10125W11H40-Z58	5+5	11	125	40	55	16	33.5	0.6	
HWMZN-14160W11H40-Z58	7+7	11	160	40	55	16	51.0	1.1	
HWMZN-16200W11H50-Z58	8+8	11	200	50	69	16	64.0	1.8	
HWMZN-22250W11H50-Z58	11+11	11	250	50	69	16	89.0	2.9	
HWMZN-8100W12H27-Z63	4+4	12	100	27	41	16	28.0	0.4	ZNMT_063
HWMZN-10125W12H40-Z63	5+5	12	125	40	55	16	33.5	0.6	
HWMZN-14160W12H40-Z63	7+7	12	160	40	55	16	51.0	1.1	
HWMZN-16200W12H50-Z63	8+8	12	200	50	69	16	64.0	1.8	
HWMZN-22250W12H50-Z63	11+11	12	250	50	69	16	89.0	2.9	
HWMZN-8100W13H27-Z68	4+4	13	100	27	41	16	28.0	0.4	ZNMT_068
HWMZN-10125W13H40-Z68	5+5	13	125	40	55	16	33.5	0.6	
HWMZN-14160W13H40-Z68	7+7	13	160	40	55	16	51.0	1.1	
HWMZN-16200W13H50-Z68	8+8	13	200	50	69	16	64.0	1.8	
HWMZN-22250W13H50-Z68	11+11	13	250	50	69	16	89.0	2.9	
HWMZN-8100W14H27-Z73	4+4	14	100	27	41	16	28.0	0.4	ZNMT_073
HWMZN-10125W14H40-Z73	5+5	14	125	40	55	16	33.5	0.6	
HWMZN-14160W14H40-Z73	7+7	14	160	40	55	16	51.0	1.1	
HWMZN-16200W14H50-Z73	8+8	14	200	50	69	16	64.0	1.8	
HWMZN-22250W14H50-Z73	11+11	14	250	50	69	16	89.0	2.9	

©STANDARD CUTTER WITHOUT INTERNAL COOLANT, INSERTS TO BE ORDERED SEPARATELY

ACCESSORY

MODEL	SCREWS	WRENCH
HWMZN-Z58/Z63	M 5012	G 20W
HWMZN-Z68/Z73		

ZNMT



INSERTS

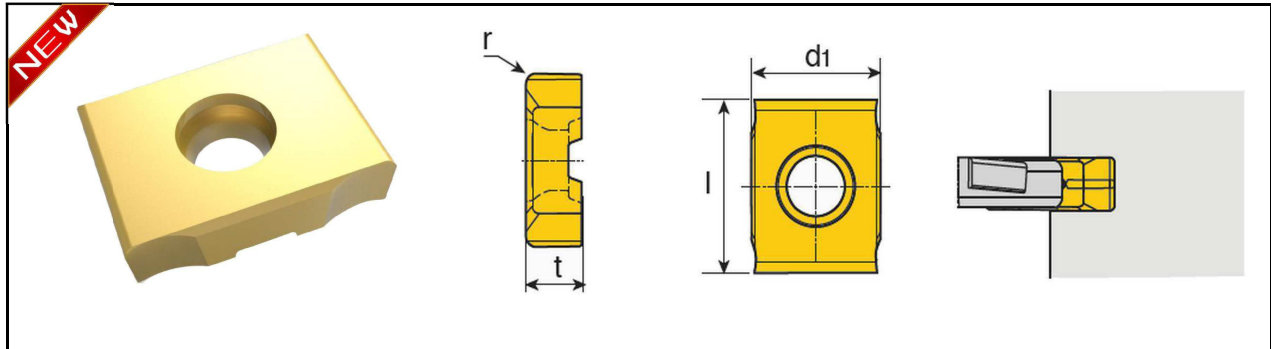

MODEL	EDGE LONG	DIMENSION MM				Feed (mm/tooth)	GRADE HW 0632
		l	d1	t	r		
ZNMT 023-04-ML	023	10	7.5	2.3	0.4	0.05~0.08	●
ZNMT 028-04-ML	028	10	7.5	2.8	0.4	0.05~0.08	●
ZNMT 033-04-ML	033	10	7.5	3.3	0.4	0.05~0.12	●
ZNMT 038-04-ML	038	13	10	3.8	0.4	0.05~0.12	●
ZNMT 043-04-ML	043	13	10	4.3	0.4	0.05~0.12	●
ZNMT 043-08-ML	043	13	10	4.3	0.8	0.05~0.12	●
ZNMT 048-04-ML	048	13	10	4.8	0.4	0.05~0.12	●
ZNMT 048-08-ML	048	13	10	4.8	0.8	0.05~0.12	●
ZNMT 053-04-ML	053	13	10	5.3	0.4	0.05~0.12	●
ZNMT 053-08-ML	053	13	10	5.3	0.8	0.05~0.12	●
ZNMT 058-04-ML	058	15	12	5.8	0.4	0.05~0.12	●
ZNMT 058-08-ML	058	15	12	5.8	0.8	0.05~0.12	●
ZNMT 063-04-ML	063	15	12	6.3	0.4	0.05~0.12	●
ZNMT 063-08-ML	063	15	12	6.3	0.8	0.05~0.12	●
ZNMT 068-08-ML	068	15	12	6.8	0.8	0.05~0.12	●
ZNMT 068-12-ML	068	15	12	6.8	1.2	0.05~0.12	●
ZNMT 073-08-ML	073	15	12	7.3	0.8	0.05~0.12	●
ZNMT 073-12-ML	073	15	12	7.3	1.2	0.05~0.12	●



CN THREE SIDED MILL CUTTER: HWMCN-H



Single-piece three-sided milling cutter HOLDER

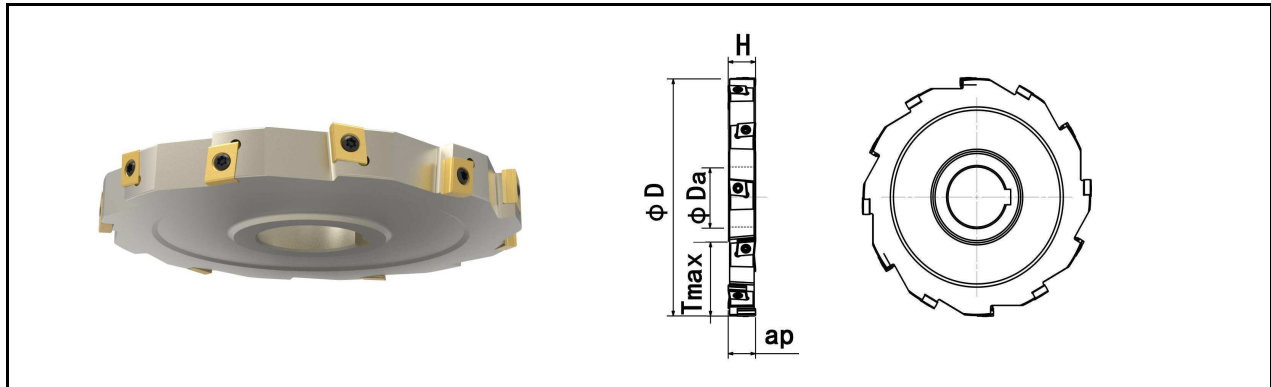

MODEL		DIMENSION MM					CONNECTOR	INSERTS
		ap	D	Da	H	Tmax		
HWMCN-663W15H22N-10	6	15	63	22	15	15	HUB	CNMX 1005
HWMCN-880W15H22N-10	8	15	80	22	15	24	HUB	
HWMCN-10100W15H27N-10	10	15	100	27	15	30	HUB	
HWMCN-12125W15H32N-10	12	15	125	32	15	40	HUB	
HWMCN-14160W15H40N-10	14	15	160	40	15	52	HUB	
HWMCN-16200W15H50N-10	16	15	200	50	15	65	HUB	
HWMCN-18250W15H60N-10	18	15	250	60	15	80	HUB	CNMX 1311
HWMCN-663W20H22N-13	6	20	63	22	20	15	HUB	
HWMCN-880W20H22N-13	8	20	80	22	20	24	HUB	
HWMCN-10100W20H27N-13	10	20	100	27	20	30	HUB	
HWMCN-12125W20H32N-13	12	20	125	32	20	40	HUB	
HWMCN-14160W20H40N-13	14	20	160	40	20	52	HUB	
HWMCN-16200W20H50N-13	16	20	200	50	20	65	HUB	CNMX 1606
HWMCN-18250W20H60N-13	18	20	250	60	20	80	HUB	
HWMCN-663W25H22N-16	6	25	63	22	25	15	HUB	
HWMCN-880W25H22N-16	8	25	80	22	25	24	HUB	
HWMCN-10100W25H27N-16	10	25	100	27	25	30	HUB	
HWMCN-12125W25H32N-16	12	25	125	32	25	40	HUB	
HWMCN-14160W25H40N-16	14	25	160	40	25	52	HUB	CNMX 1606
HWMCN-16200W25H50N-16	16	25	200	50	25	65	HUB	
HWMCN-18250W25H60N-16	18	25	250	60	25	80	HUB	

◎STANDARD. CUTTER WITHOUT.

◎THIS HOLDER WITH 3 COMMON INSERTS, CN 10, . CN 13, . CN 16, YOU CAN CHOOSE AS YOUR REQUEST.

◎CUT WIDTH RANGE 14~30mm, CUTTER MAX DIA φ 700mm, CAN BE CUSTOMIZED. IF YOU NEED.

◎INSERTS TO BE ORDERED SEPARATELY

MILLING CUTTER INSERTS



CN**08/10/12/13/16

INSERTS	SHAPE					INTRODUCTION	INSERT PAGE				
						<ul style="list-style-type: none"> • Vertical blade • Central blade, no distinction LEFT/RIGHT	B150				
INSERT MODEL	EDGE LONG	DIMENSION MM				FEED (mm/TEETH)	GRADE				
		l	d1	t	r		HW0632	HW0622	HW1804	HW1814	HWA7
CNMX 100504-ML	10	—	—	—	0.4	0.1~0.3	●	●	●	●	
CNMX 100508-ML	10	—	—	—	0.8	0.1~0.3	●	●	●	●	
CNMX 100512-ML	10	—	—	—	1.2	0.1~0.3	●	●	●	●	
CNMX 100516-ML	10	—	—	—	1.6	0.1~0.3	●	●	●	●	
CNMX 121116	12	—	—	—	2.4	0.1~0.3	●	●	●	●	
CNMX 121120	12	—	—	—	3.0	0.1~0.3	●	●	●	●	
CNMX 131104-ML	13	12.7	11	5.4	0.4	0.1~0.35	●	●	●	●	
CNMX 131108-ML	13	12.7	11	5.4	0.8	0.1~0.35	●	●	●	●	
CNMX 131112-ML	13	12.7	11	5.4	1.2	0.1~0.35	●	●	●	●	
CNMX 131116-ML	13	12.7	11	5.4	1.6	0.1~0.35	●	●	●	●	
CNMX 131124-ML	13	12.7	11	5.4	2.4	0.1~0.35	●	●	●	●	
CNMX 131130-ML	13	12.7	11	5.4	3.0	0.1~0.35	●	●	●	●	
CNMX 160604-ML	16	16.0	12	6.4	0.4	0.1~0.4	●	●	●	●	
CNMX 160608-ML	16	16.0	12	6.4	0.8	0.1~0.4	●	●	●	●	
CNMX 160612-ML	16	16.0	12	6.4	1.2	0.1~0.4	●	●	●	●	
CNMX 160616-ML	16	16.0	12	6.4	1.6	0.1~0.4	●	●	●	●	
CNMX 160624-ML	16	16.0	12	6.4	2.4	0.1~0.4	●	●	●	●	
CNMX 160630-ML	16	16.0	12	6.4	3.0	0.1~0.4	●	●	●	●	

ACCESSORY

MODEL	SCREWS	WRENCH
HWMCN-10	M 4013-P	G 15W-P
HWMCN-13	M 4013-P	G 15W-P
HWMCN-16	M 5016	G 20W

Thread milling series: HWR00



Thread Milling Shank (Single Insert)

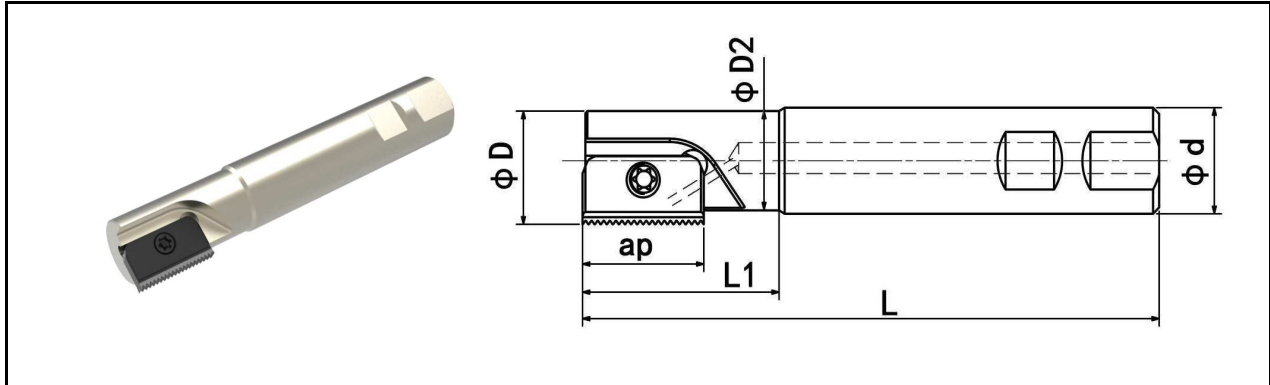

MODEL		DIMENSION MM					INSERT ap (mm)
		D	D2	L1	L	d	
HWR0009H12	1	9.5	7.5	14	85	20	TMT12
HWR0010H12	1	9.9	7.6	16	85	20	TMT12
HWR0012F14	1	12.0	8.9	20	75	20	TMT14
HWR0014H14	1	14.5	11.2	25	85	20	TMT14
HWR0017H14	1	17.0	13.4	30	85	20	TMT14
HWR0018H21	1	18.0	14.4	30	85	20	TMT21
HWR0021H21	1	21.0	16.5	40	94	20	TMT21
HWR0029J30	1	29.0	22.4	50	110	25	TMT30
HWR0048M40	1	48.0	35.0	78	153	40	TMT40

©STANDARD CUTTER WITH INTERNAL COOLANT

©ONLY COMPATIBLE WITH INSERTS: 12-18NPT, 12-18PTF, 12-19BSPT

©SR0018H21 NOT COMPATIBLE WITH: 2113.5ISO, 2117UN, 2118UN 21-11BSPT, 21-11.5NPT, 21-11.5NPTF

©INSERTS TO BE ORDERED SEPARATELY, COMPATIBLE WITH TAEGUTEC INSERTS

ACCESSORY

MODEL	SCREWS	WRENCH
SR 12	M12	G12
SR 14	M14	G14
SR 21	M21	G21
SR 30	M30	G30
SR 40	M40	G40

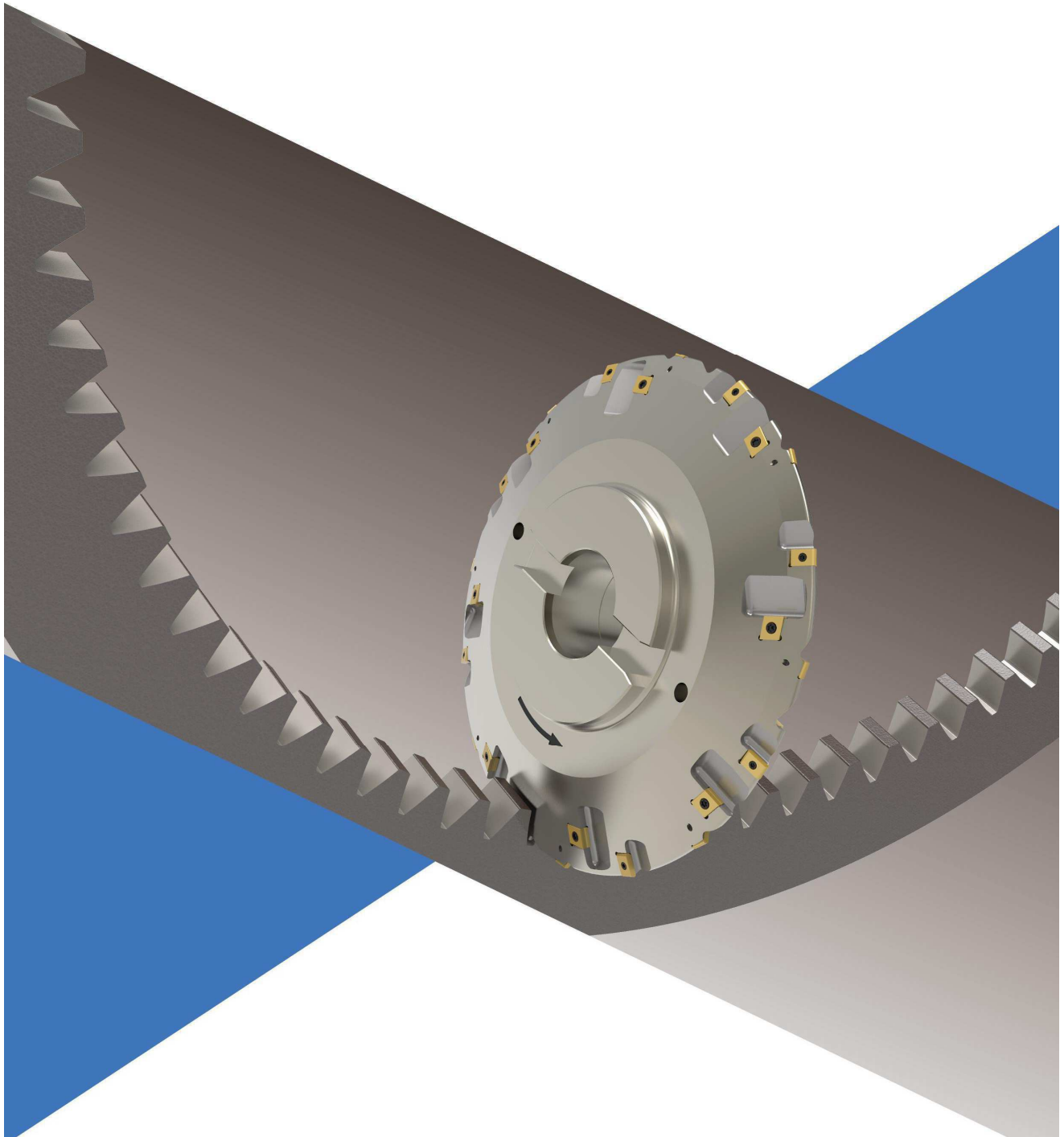



Industry Application

Blade type gear iron cutter is mainly suitable for processing various large and medium-sized transmission gear rings and racks, such as transmission parts in wind power, engineering machinery, machine tools, construction and other industries .

The gear milling cutters and blades developed and produced by Hanwoo are of fine workmanship and stable quality. After actual use and inspection by customer, they have excellent performance, reliable structure, long tool life and high cost performance. They are the first choice for customer to replace import.

In response to the differentiated needs of customer, we can customize non-standard cutter discs and blades to improve production efficiency, effectively reduce customers' production costs, and achieve the goal of reducing cost and increase efficiency.

Hanwoo will discuss product differentiation and innovation with you, explore product matching solutions, and work together for win-win results.

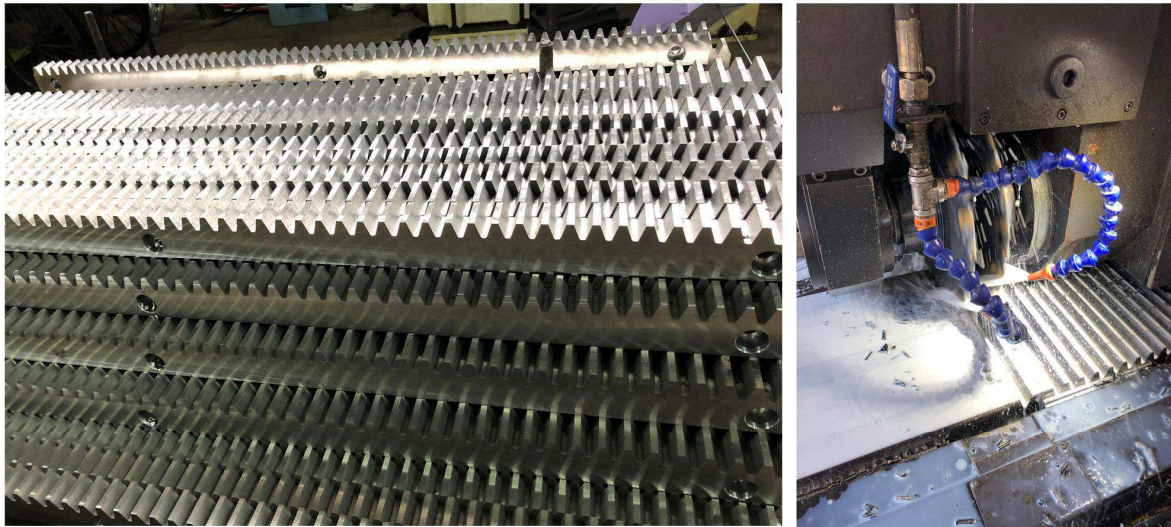
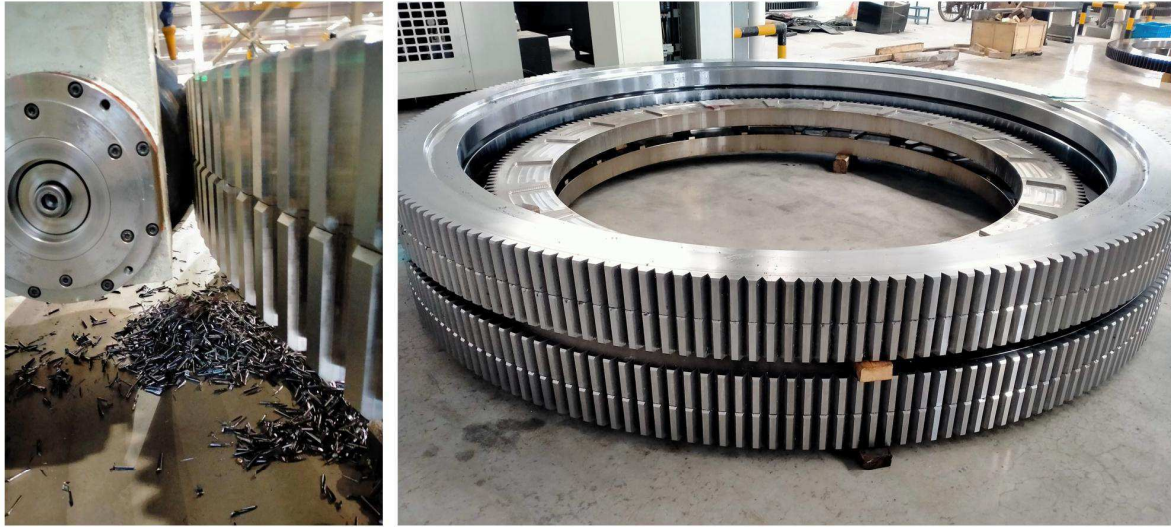

Gear and rack processing case

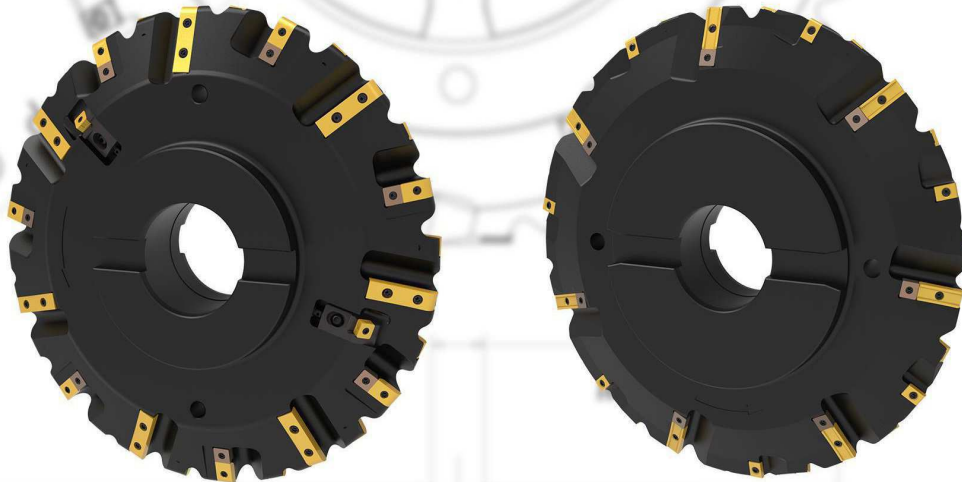
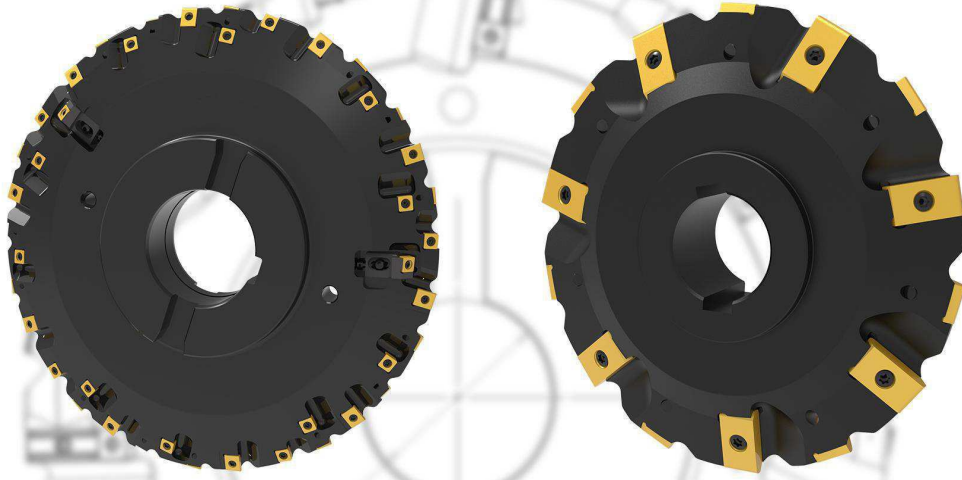

Gear Rough Milling Series: HWM...A



Gear Rough Milling Cutter

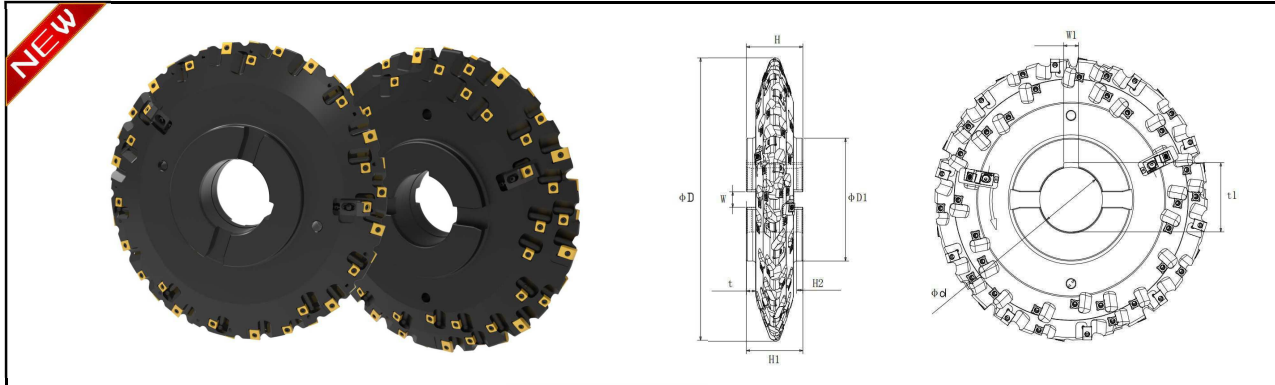

MODEL		DIMENSIONS					MOULD	INSERTS
		D	d	H	z _{eff.}	D1		
HWM-40400D90W80-M10A	40	400	90	80	8/4	190	10	16xC, 24xY/Z
HWM-56450D100W90-M10A	56	450	100	90	10/5	190		20xC 36xY/Z
HWM-40400D90W80-M12A	40	400	90	80	8/4	190	12	16xD, 24xY/Z
HWM-56450D100W90-M12A	56	450	100	90	10/5	190		20xD 36xY/Z
HWM-40400D90W80-M14A	40	400	90	80	8/4	190	14	16xE, 24xY/Z
HWM-56450D100W90-M14A	56	450	100	90	10/5	190		20xE 36xY/Z
HWM-40400D90W80-M16A	40	400	90	80	8/4	190	16	16xF, 24xY/Z
HWM-56450D100W90-M16A	56	450	100	90	10/5	190		20xF 36xY/Z
HWM-40400D90W80-M18A	40	400	90	80	8/4	190	18	16xG, 24xY/Z
HWM-56450D100W90-M18A	56	450	100	90	10/5	190		20xG 36xY/Z
HWM-48400D90W80-M20A	48	400	90	80	8/4	190	20	16xH, 32xY/Z
HWM-60450D100W90-M20A	60	450	100	90	10/5	190		20xH 40xY/Z
HWM-48400D90W80-M22A	48	400	90	80	8/4	190	22	16xI, 32xY/Z
HWM-60450D100W90-M22A	60	450	100	90	10/5	190		20xI 40xY/Z
HWM-48400D90W80-M24A	48	400	90	80	8/4	190	24	16xJ, 32xY/Z
HWM-60450D100W90-M24A	60	450	100	90	10/5	190		20xJ 40xY/Z

© ABOVE IS ONLY FOR REFERENCE.

© STANDARD CUTTER WITHOUT INTERNAL COOLANT

© INSERTS TO BE ORDERED SEPARATELY

Gear two-station precision milling series: HWM...B



Gear Two-Station Fine Milling Cutter

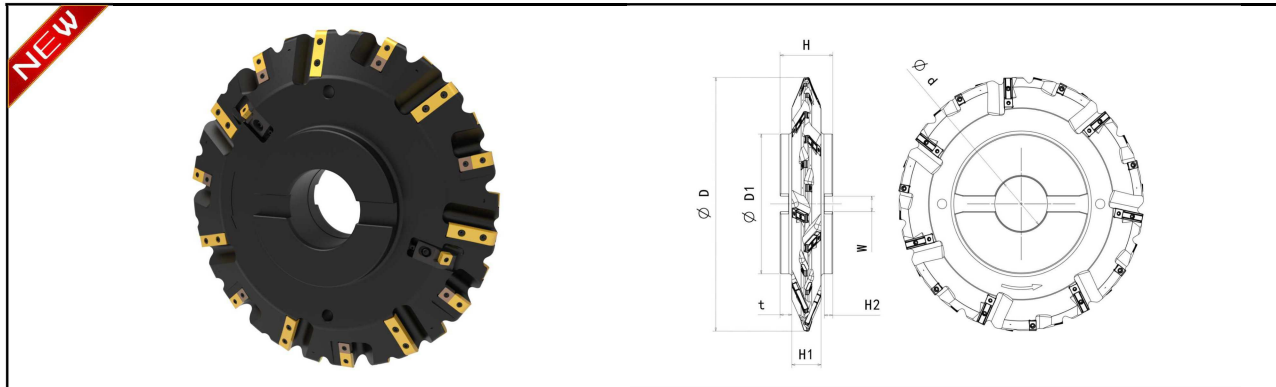

MODEL		DIMENSIONS					MOULD	INSERTS
		D	d	H	zeff.	D1		
HWM-28400D100W90-M10B	28	400	100	90	7/7	190	10	14xA, 14xC
HWM-32450D100W90-M10B	32	450	100	90	8/8	190		16xA 16xC
HWM-28400D100W90-M12B	28	400	100	90	7/7	190	12	14xA, 14xD
HWM-32450D100W90-M12B	32	450	100	90	8/8	190		16xA 16xD
HWM-28400D100W90-M14B	28	400	100	90	7/7	190	14	14xA, 14xE
HWM-32450D100W90-M14B	32	450	100	90	8/8	190		16xA 16xE
HWM-28400D100W90-M16B	28	400	100	90	7/7	190	16	14xA, 14xF
HWM-32450D100W90-M16B	32	450	100	90	8/8	190		16xA 16xF
HWM-28400D100W90-M18B	28	400	100	90	7/7	190	18	14xA, 14xG
HWM-32450D100W90-M18B	32	450	100	90	8/8	190		16xA 16xG
HWM-28400D100W90-M20B	28	400	100	90	7/7	190	20	14xB, 14xH
HWM-32450D100W90-M20B	32	450	100	90	8/8	190		16xB 16xH
HWM-28400D100W90-M22B	28	400	100	90	7/7	190	22	14xB, 14xI
HWM-32450D100W90-M22B	32	450	100	90	8/8	190		16xB 16xI
HWM-28400D100W90-M24B	28	400	100	90	7/7	190	24	14xB, 14xJ
HWM-32450D100W90-M24B	32	450	100	90	8/8	190		16xB 16xJ

© ABOVE IS ONLY FOR REFERENCE.

© STANDARD CUTTER WITHOUT INTERNAL COOLANT

© INSERTS TO BE ORDERED SEPARATELY

Gear Four-Station Fine Milling Series: HWM...C



Gear Four-Station Fine Milling Cutter

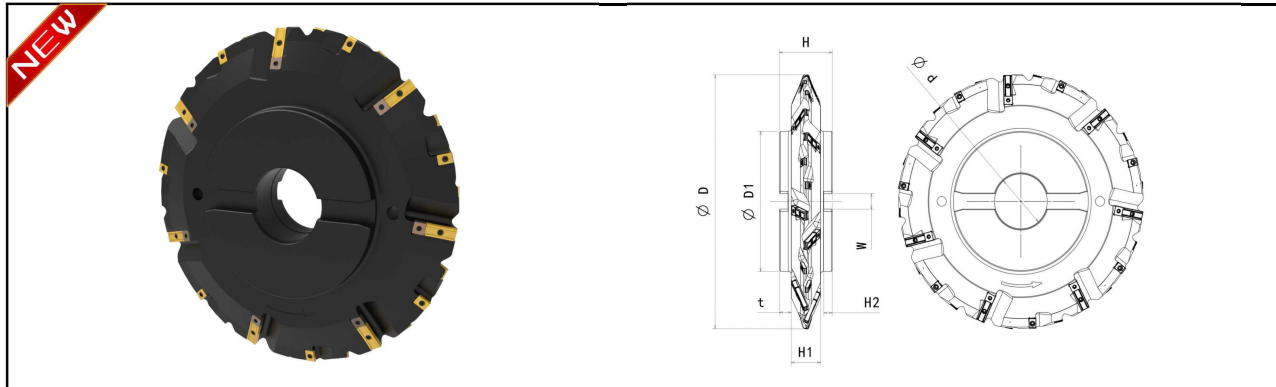

MODEL		DIMENSIONS					MOULD	INSERTS
		D	d	H	z _{eff.}	D1		
HWM-28400D100W90-M10C	28	400	100	90	7/7	190	10	14xA1, 14xC
HWM-32450D100W90-M10C	32	450	100	90	8/8	190		16xA1 16xC
HWM-28400D100W90-M12C	28	400	100	90	7/7	190	12	14xA1, 14xD
HWM-32450D100W90-M12C	32	450	100	90	8/8	190		16xA1 16xD
HWM-28400D100W90-M14C	28	400	100	90	7/7	190	14	14xA1, 14xE
HWM-32450D100W90-M14C	32	450	100	90	8/8	190		16xA1 16xE
HWM-28400D100W90-M16C	28	400	100	90	7/7	190	16	14xA1, 14xF
HWM-32450D100W90-M16C	32	450	100	90	8/8	190		16xA1 16xF
HWM-28400D100W90-M18C	28	400	100	90	7/7	190	18	14xA1, 14xG
HWM-32450D100W90-M18C	32	450	100	90	8/8	190		16xA1 16xG

©ABOVE IS ONLY FOR REFERENCE.

©STANDARD CUTTER WITHOUT INTERNAL COOLANT

©INSERTS TO BE ORDERED SEPARATELY

GEAR Rack series: HWMLN...



GEAR RACK MILL CUTTER

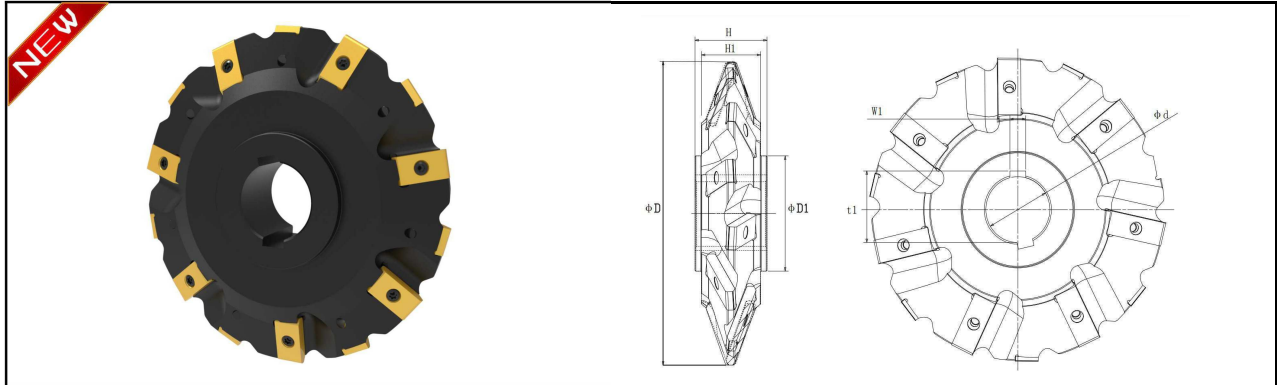

MODEL		DIMENSIONS		MOULD	INSERTS
		D	d		
HWMLN-14180D40-M8	14	180	40	8	CLX291406M08
HWMLN-22315D40-M8	22	315	40		
HWMLN-14180D40-M10	14	180	40	10	CLX291406M10
HWMLN-22315D40-M10	22	315	40		
HWMLN-14180D40-M12	14	180	40	12	CLX401406M12
HWMLN-22315D40-M12	22	315	40		
HWMLN-14180D40-M14	14	180	40	14	CLX401406M14
HWMLN-22315D40-M14	22	315	40		
HWMLN-14180D40-M16	14	180	40	16	CLX401406M16
HWMLN-22315D40-M16	22	315	40		
HWMLN-14180D40-M18	14	180	40	18	CLX401406M18
HWMLN-22315D40-M18	22	315	40		
HWMLN-14180D40-M20	14	180	40	20	CLX501406M20
HWMLN-22315D40-M20	22	315	40		
HWMLN-14180D40-M22	14	180	40	22	CLX601409M22
HWMLN-22315D40-M22	22	315	40		
HWMLN-14180D40-M24	14	180	40	24	CLX601409M24
HWMLN-22315D40-M24	22	315	40		

© ABOVE IS ONLY FOR REFERENCE.

© STANDARD CUTTER WITHOUT INTERNAL COOLANT

© INSERTS TO BE ORDERED SEPARATELY

Gear Milling Series



Gear Milling Inserts

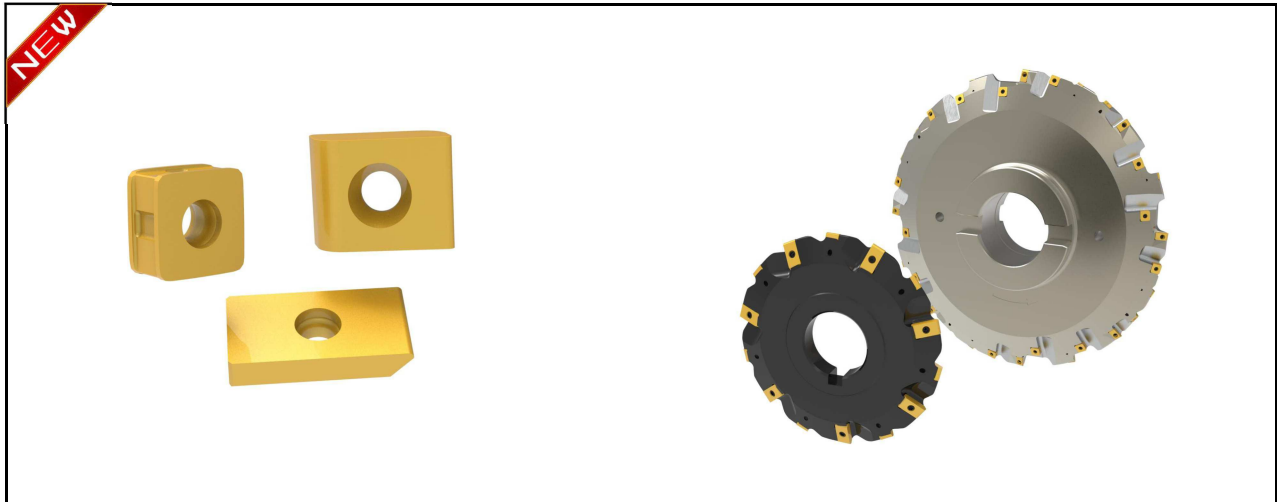

INSERT CODE	MOULD	DIMENSIONS				
		L	H	W	R	HOLE
C	10	19.05	14.3	4.8	3.8	5.4
D	12	19.05	14.3	6.35	4.56	5.4
E	14	19.05	14.3	6.35	5.32	5.4
F	16	19.05	14.3	7.14	6.08	5.4
G	18	19.05	14.3	7.14	6.84	5.4
H	20	25.4	14.3	7.98	7.6	5.5
I	22	25.4	14.3	7.98	7.6	5.5
J	24	25.4	14.3	7.98	7.6	5.5

INSERT	insert code	DIMENSIONS			
		L	H	W	CENTER HOLE
SNEA 1370	Y	13.02	13.02	7.0	4.4
CLX121206	Z	12.7	12.7	6.35	4.5





©for reference only

Gear Milling Series

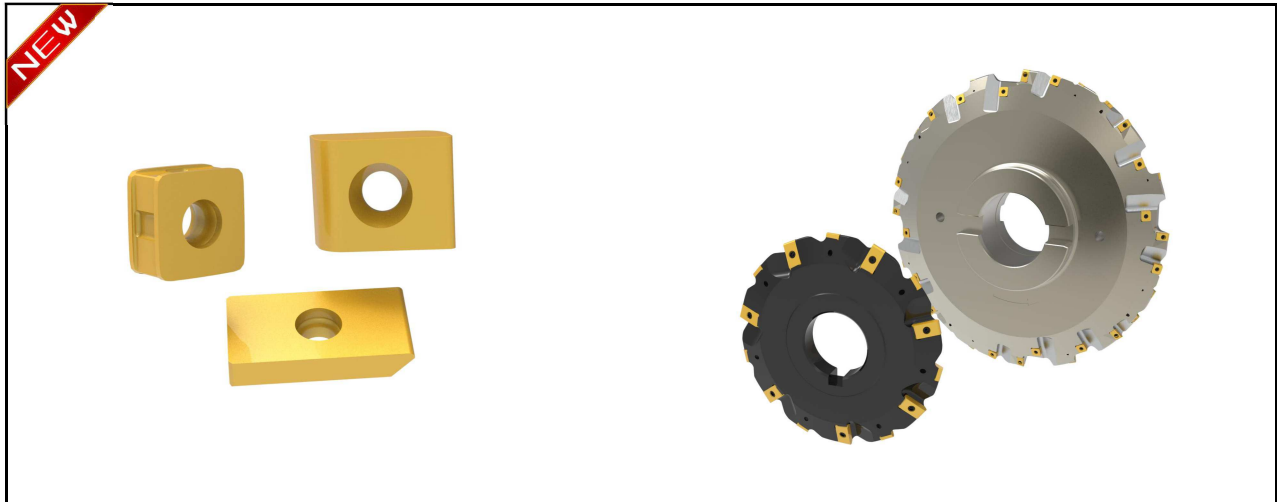

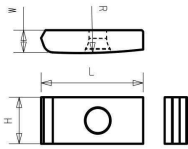
Gear Milling Inserts

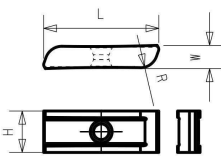

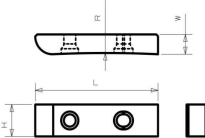
		INSERT CODE	DIMENSIONS			
			L	H	W	CENTER
		A	25.4	6.4	14.3	5.5
			28.3	5.2	14.3	5.5
			32	7	14.3	5.5
			38	7	14.3	5.5
			40.7	8	14.3	5.5
			42	8.5	14.3	5.5
		A1	25.4	6.4	14.3	5.5
			28.3	5.2	14.3	5.5
			32	7	14.3	5.5
			38	7	14.3	5.5
			40.7	8	14.3	5.5
			42	8.5	14.3	5.5
		B	54	14.3	7.8	5.7双
			57	14.3	8.8	5.7双

©for reference only. to be customized as to your request.

Gear rack series



gear rack inserts

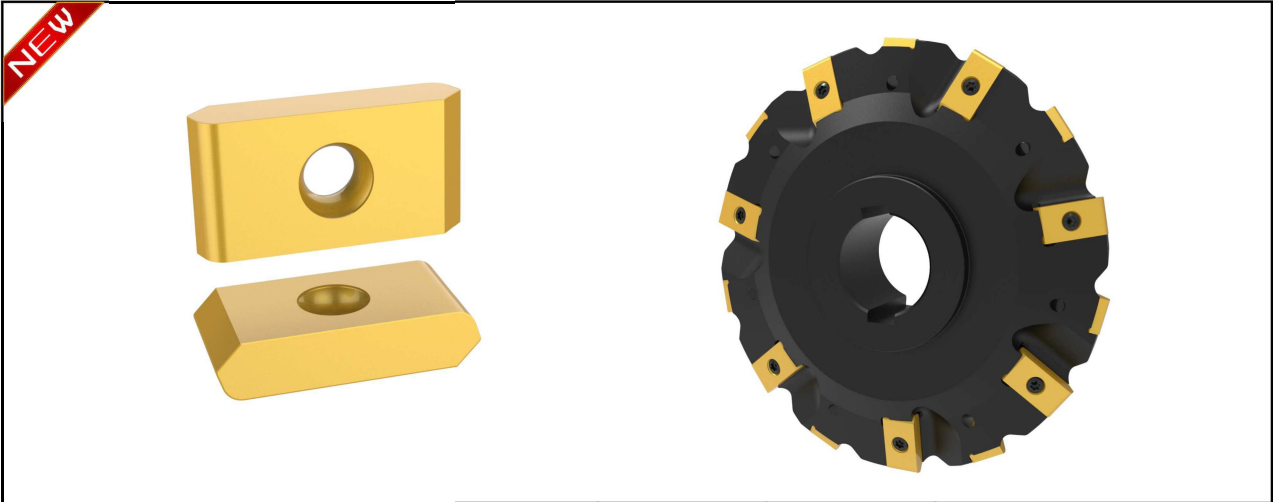

		INSERT MODEL	MOULD	DIMENSIONS			
				L	H	W	CENTER
		CLX301406	08/10	30	14.3	6	5.5
		CLX401406	12	40	14.3	6	5.5
		CLX501408	12/14/16/18	50	14.3	8	5.5d
		CLX601409	22/24	60	14.3	9	5.5D

©for reference only. to be customized as to your request.

ORDERING INFORMATION

TOOLS DATA

Outside diameter / D _____
 Bore diameter / d _____
 Hub diameter / D1 _____
 Cutter width / H _____
 Hub width / H1 _____
 Radian keyway width / W _____
 Radian keyway depth / t _____
 Axial key way width/W1 _____
 Axial key way depth/t1 _____

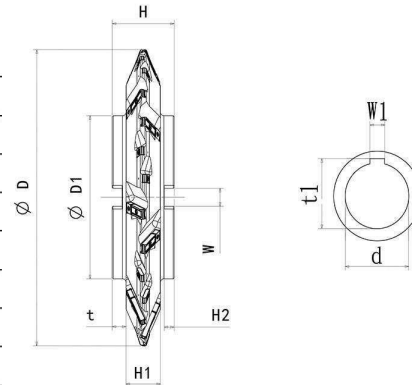

GEAR INFORMATION

GEAR TYPE Internal / External / Rack

Module / M _____

NO.of teeth / z _____

Pressure angle / α _____

Helix angle / β _____

Addendum modification coefficient/ X_n _____

Tip diameter/ D_a _____

Root diameter/ D_f _____

Root radius/ R_f _____

Base tangent length over k/ W_k _____

Number of measuring teeth/k _____

Dimension over ball/ M_d _____

Ball diameter/d _____

Normal circular thickness of finishing/ S_n _____

Gear quality class _____

Process Roughing / Semi-finishing / Finishing

Side stock for roughing _____

Tip stock for roughing _____

INSERT REQUIMENTS

Long insert for side (No of Effective edge) _____

Insert for tip _____

Insert for side _____

Shim _____

Marking _____

Screw _____



→ HOLE MAKING SERIES ←

Drilling for Steel, Cast Steel, Cast Iron, Malleable Cast Iron

- ▶ Self centering and chip breaking by R-thinning
- ▶ Wave shape and negative land on the cutting edge for low thrust, stable torque and long tool life
- ▶ Optimized flute shape for strength of drilling and smooth chip evacuation



XOMX / SPMG



Drilling inserts

XOMX inserts

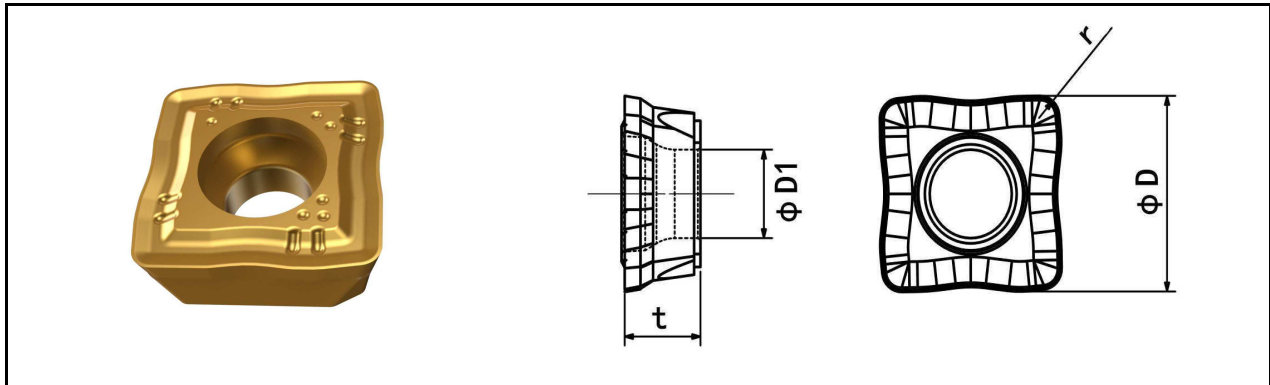

inserts model	dimensions				screw	grade
	D	t	r	D1		
XOMX 050204	4.9	2.38	0.4	2.25	CSG2049-P	●
XOMX 060204	5.7	2.38	0.4	2.60	CSG2252-P	
XOMX 070306	6.8	2.80	0.6	2.60	CSG2252-P	
XOMX 08T306	7.9	3.97	0.6	2.85	CSG2565-P	
XOMX 09T308	9.2	3.97	0.8	3.80	CSG3585-P	
XOMX 11T308	11.0	3.97	0.8	3.80	CSG3585-P	
XOMX 130408	12.8	4.40	0.8	4.40	CSG4011-P	
XOMX 150510	15.0	4.80	1.0	5.40	CSG5012-P	

SPMGinserts

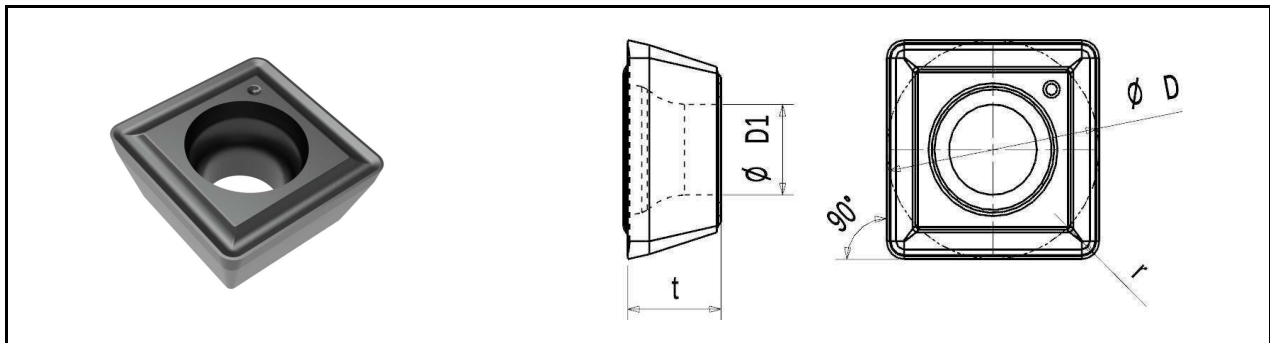

inserts model	dimensions				screw	grade
	D	t	r	D1		
SPMG 050204-PM	5.00	2.38	0.4	2.25	CSG2049-P	●
SPMG 060204-PM	6.00	2.38	0.4	2.61	CSG2252-P	
SPMG 07T308-PM	7.94	3.97	0.8	2.85	CSG2565-P	
SPMG 090408-PM	9.80	4.30	0.8	4.05	CSG3585-P	
SPMG 110408-PM	11.5	4.80	0.8	4.45	CSG4011-P	

HWXOP 2 . . -T2



Drilling tool series: indexable drill shank

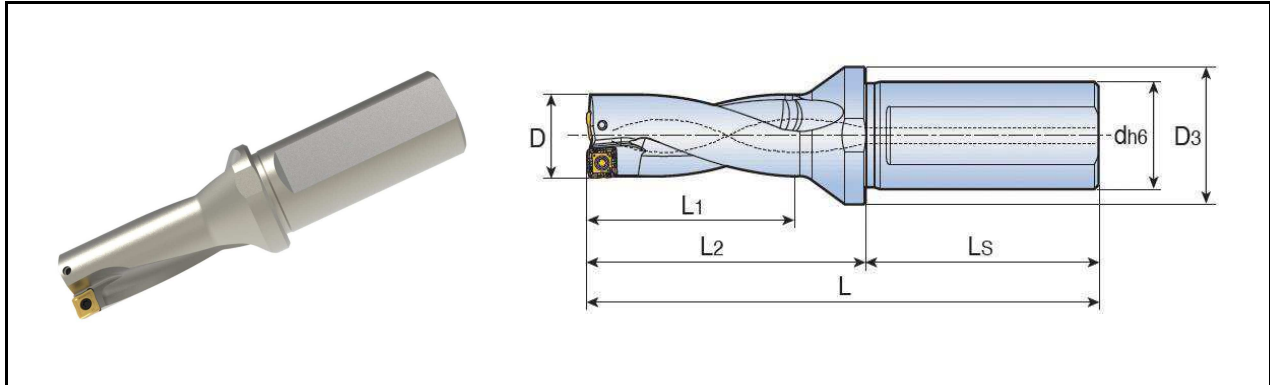

©drilling depth: 2xD(diameter)

product model	dimensions							compatible inserts
	D	d	D3	L	L1	L2	Ls	
HWXOP 2140-20T2-05	14.0	20	25	96	28	46	50	XOMX 05
HWXOP 2145-20T2-05	14.5	20	25	99	30	49	50	
HWXOP 2150-20T2-05	15.0	20	25	99	30	49	50	
HWXOP 2155-20T2-05	15.5	20	25	102	32	52	50	
HWXOP 2160-20T2-05	16.0	20	25	102	32	52	50	
HWXOP 2165-25T2-06	16.5	25	32	110	34	54	56	XOMX 06
HWXOP 2170-25T2-06	17.0	25	32	110	34	54	56	
HWXOP 2175-25T2-06	17.5	25	32	113	36	57	56	
HWXOP 2180-25T2-06	18.0	25	32	113	36	57	56	
HWXOP 2185-25T2-06	18.5	25	32	115	38	59	56	
HWXOP 2190-25T2-06	19.0	25	32	115	38	59	56	XOMX 07
HWXOP 2195-25T2-07	19.5	25	32	119	40	63	56	
HWXOP 2200-25T2-07	20.0	25	32	119	40	63	56	
HWXOP 2205-25T2-07	20.5	25	32	121	42	65	56	
HWXOP 2210-25T2-07	21.0	25	32	121	42	65	56	
HWXOP 2215-25T2-07	21.5	25	32	123	44	67	56	XOMX 08
HWXOP 2220-25T2-07	22.0	25	32	123	44	67	56	
HWXOP 2225-25T2-08	22.5	25	32	124	46	68	56	
HWXOP 2230-25T2-08	23.0	25	32	124	46	68	56	
HWXOP 2230-32T2-08	23.0	32	40	128	46	68	60	
HWXOP 2235-25T2-08	23.5	25	32	126	48	70	56	XOMX 08
HWXOP 2235-32T2-08	23.5	32	40	130	48	70	60	
HWXOP 2240-25T2-08	24.0	25	32	126	48	70	56	

HWXOP 2 . . -T2



Indexable drill shank

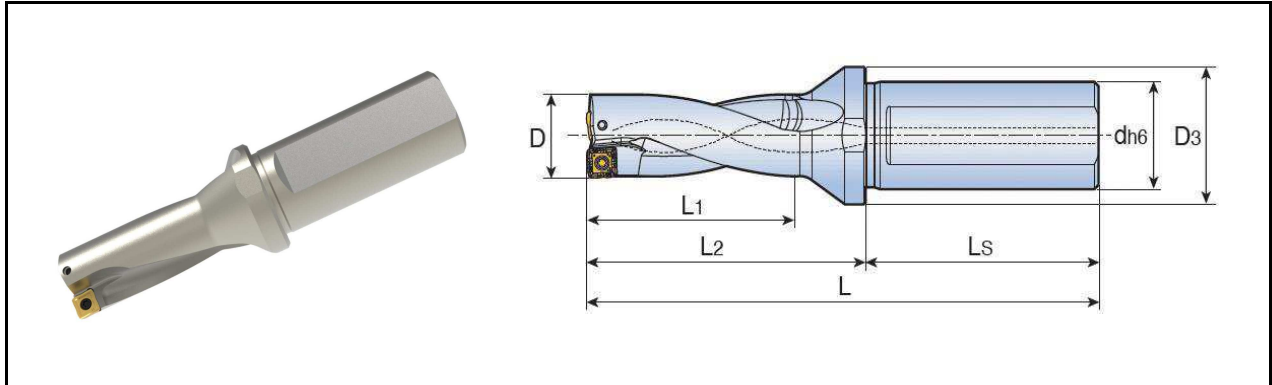

©drilling depth: 2xD(diameter)

product model	dimensions							compatibl inserts
	D	d	D3	L	L1	L2	Ls	
HWXOP 2240-32T2-08	24.0	32	40	130	48	70	60	XOMX 08
HWXOP 2245-25T2-08	24.5	25	32	128	50	72	56	
HWXOP 2245-32T2-08	24.5	32	40	132	50	72	60	
HWXOP 2250-25T2-08	25.0	25	32	128	50	72	56	
HWXOP 2250-32T2-08	25.0	32	40	132	50	72	60	
HWXOP 2255-25T2-08	25.5	25	32	129	52	73	56	
HWXOP 2255-32T2-08	25.5	32	40	133	52	73	60	
HWXOP 2260-25T2-08	26.0	25	32	129	52	73	56	
HWXOP 2260-32T2-08	26.0	32	40	133	52	73	60	
HWXOP 2265-32T2-09	26.5	32	40	137	54	77	60	
HWXOP 2270-25T2-09	27.0	25	40	133	54	77	56	
HWXOP 2270-32T2-09	27.0	32	40	137	54	77	60	
HWXOP 2275-32T2-09	27.5	32	40	139	56	79	60	
HWXOP 2280-25T2-09	28.0	25	40	135	56	79	56	
HWXOP 2280-32T2-09	28.0	32	40	139	56	79	60	
HWXOP 2285-32T2-09	28.5	32	40	141	58	81	60	
HWXOP 2290-25T2-09	29.0	25	40	137	58	81	56	
HWXOP 2290-32T2-09	29.0	32	40	141	58	81	60	
HWXOP 2295-32T2-09	29.5	32	40	143	60	83	60	
HWXOP 2300-32T2-09	30.0	32	40	143	60	83	60	
HWXOP 2305-32T2-09	30.5	32	40	145	62	85	60	
HWXOP 2310-32T2-09	31.0	32	40	145	62	85	60	

©Standard shank with internal coolant

©insertsTo be ordered separately

©There is no threaded interface at the end of the standard shank

©cooling hole plug for lathe. To be ordered separately

HWXOP 2...-T2



Indexable drill shank

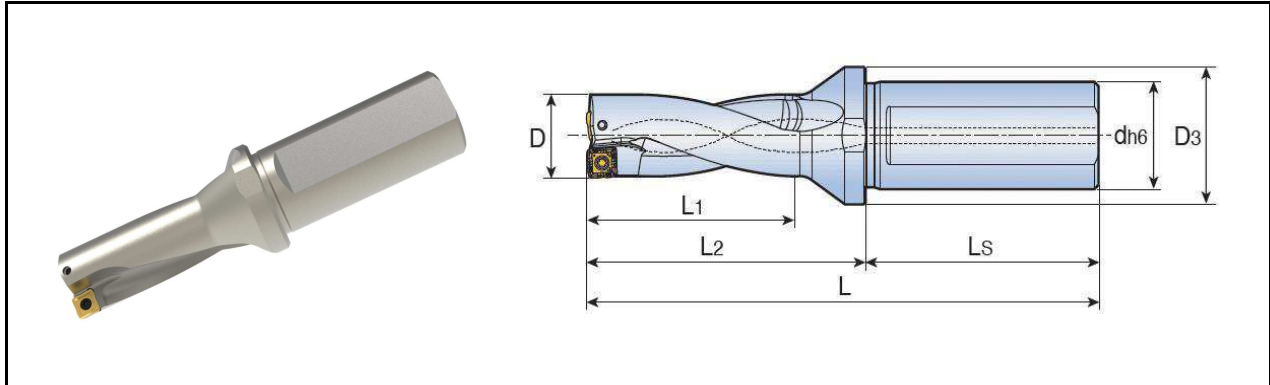

©drilling depth: 2xD(diameter)

product model	dimensions							compatible inserts
	D	d	D3	L	L1	L2	Ls	
HWXOP 2320-32T2-11	32.0	32	40	147	64	87	60	XOMX 11
HWXOP 2320-40T2-11	32.0	40	50	157	64	87	70	
HWXOP 2330-32T2-11	33.0	32	40	149	66	89	60	
HWXOP 2330-40T2-11	33.0	40	50	159	66	89	70	
HWXOP 2340-32T2-11	34.0	32	40	151	68	91	60	
HWXOP 2340-40T2-11	34.0	40	50	161	68	91	70	
HWXOP 2350-32T2-11	35.0	32	40	153	70	93	60	
HWXOP 2350-40T2-11	35.0	40	50	163	70	93	70	
HWXOP 2360-32T2-11	36.0	32	40	155	72	95	60	
HWXOP 2360-40T2-11	36.0	40	50	165	72	95	70	
HWXOP 2370-32T2-13	37.0	32	50	162	74	102	60	XOMX 13
HWXOP 2370-40T2-13	37.0	40	50	172	74	102	70	
HWXOP 2380-32T2-13	38.0	32	50	164	76	104	60	
HWXOP 2380-40T2-13	38.0	40	50	174	76	104	70	
HWXOP 2390-32T2-13	39.0	32	50	166	78	106	60	
HWXOP 2390-40T2-13	39.0	40	50	176	78	106	70	
HWXOP 2400-32T2-13	40.0	32	50	168	80	108	60	
HWXOP 2400-40T2-13	40.0	40	50	178	80	108	70	
HWXOP 2410-40T2-13	41.0	40	50	180	82	110	70	
HWXOP 2420-40T2-13	42.0	40	50	182	84	112	70	
HWXOP 2430-40T2-13	43.0	40	50	184	86	114	70	

HWXOP 2...-T2



Indexable drill shank

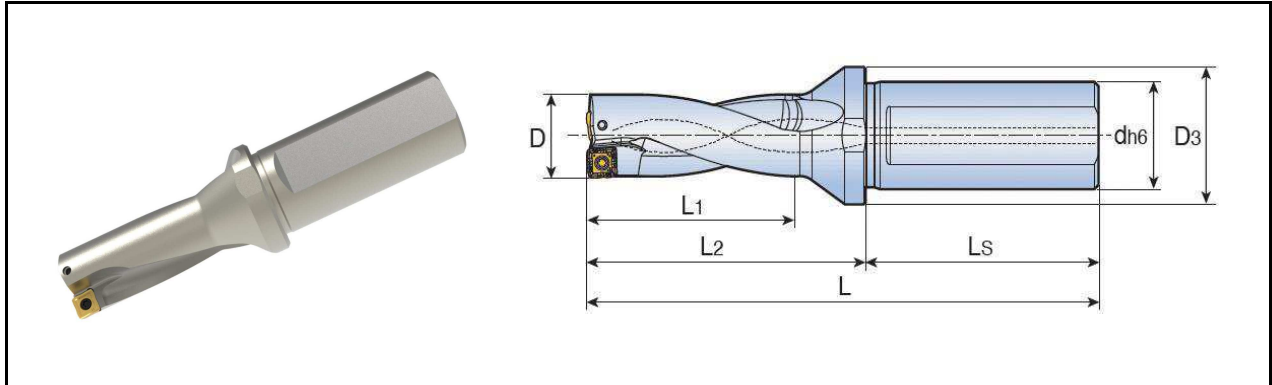

©drilling depth: 2xD(diameter)

product model	dimensions							compatible inserts
	D	d	D3	L	L1	L2	Ls	
HWXOP 2440-40T2-15	44.0	40	60	193	88	123	70	XOMX 15
HWXOP 2450-40T2-15	45.0	40	60	195	90	125	70	
HWXOP 2460-40T2-15	46.0	40	60	197	92	127	70	
HWXOP 2470-40T2-15	47.0	40	60	199	94	129	70	
HWXOP 2480-40T2-15	48.0	40	60	201	96	131	70	
HWXOP 2490-40T2-15	49.0	40	60	203	98	133	70	
HWXOP 2500-40T2-15	50.0	40	60	205	100	135	70	

©Standard shank with internal coolant

©inserts To be ordered separately

©There is no threaded interface at the end of the standard shank

©cooling hole plug for lathe To be ordered separately

accessory

product model	screw	wrench	cooling hole plug	
HWXOP 2140-2160	M 2049-P	G 06W-P	SL 20	©:cooling hole plug for lathe , to be ordred separately ©:*cooling hole plug for lathe . model according to shank dia. if diameter: 32mm, then cooling hole plug for lathe . model CSL 32
HWXOP 2165-2220	M 2252-P	G 07W-P	SL 25	
HWXOP 2225-2260	M 2565-P	G 08W-P	SL 25/SL 32	
HWXOP 2265-2360	M 3585-P	G 10W-P	SL 25/SL 32	
HWXOP 2370-2430	M 4011-P	G 15W-P	SL 32/SL 40	
HWXOP 2440-2550	M 5012-P	G 20W-P	SL 32/SL 40	

HWXOP 3...-T2



Indexable drill shank

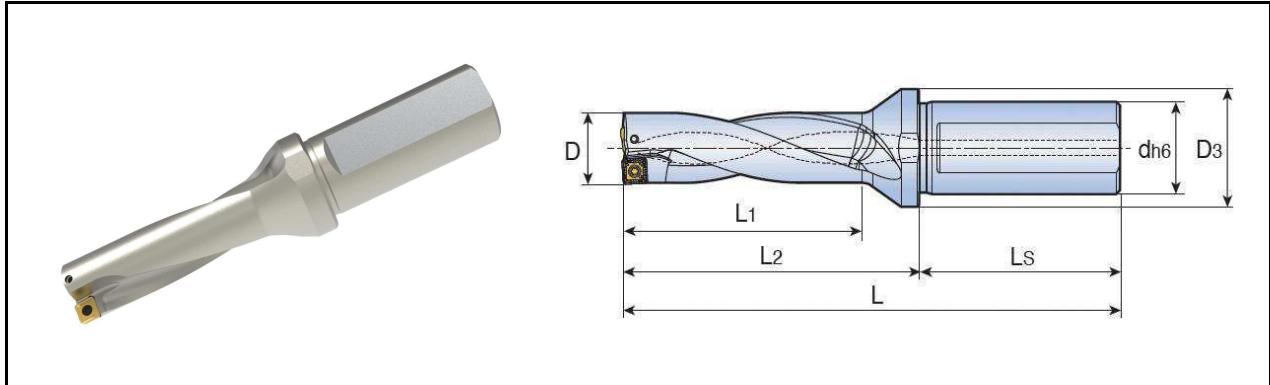

©drilling depth: 3xD(diameter)

product model	dimensions							compatible inserts
	D	d	D3	L	L1	L2	Ls	
HWXOP 3140-20T2-05	14.0	20	25	110	42	60	50	XOMX 05
HWXOP 3145-20T2-05	14.5	20	25	114	45	64	50	
HWXOP 3150-20T2-05	15.0	20	25	114	45	64	50	
HWXOP 3155-20T2-05	15.5	20	25	118	48	68	50	
HWXOP 3160-20T2-05	16.0	20	25	118	48	68	50	
HWXOP 3165-25T2-06	16.5	25	32	127	51	71	56	XOMX 06
HWXOP 3167-25T2-06 *	16.7	25	32	127	50.1	71	56	
HWXOP 3170-25T2-06	17.0	25	32	131	51	71	56	
HWXOP 3175-25T2-06	17.5	25	32	131	54	75	56	
HWXOP 3180-25T2-06	18.0	25	32	134	54	75	56	
HWXOP 3185-25T2-06	18.5	25	32	134	57	78	56	XOMX 07
HWXOP 3190-25T2-06	19.0	25	32	139	57	78	56	
HWXOP 3195-25T2-07	19.5	25	32	139	60	83	56	
HWXOP 3200-25T2-07	20.0	25	32	142	60	83	56	
HWXOP 3205-25T2-07	20.5	25	32	142	63	86	56	
HWXOP 3210-25T2-07	21.0	25	32	145	63	86	56	XOMX 08
HWXOP 3215-25T2-07	21.5	25	32	145	66	89	56	
HWXOP 3220-25T2-07	22.0	25	32	145	66	89	56	
HWXOP 3222-25T2-07 *	22.2	25	32	147	66.6	89	56	
HWXOP 3225-25T2-08	22.5	25	32	147	69	91	56	
HWXOP 3230-25T2-08	23.0	25	32	151	69	91	56	XOMX 08
HWXOP 3230-32T2-08	23.0	32	40	150	69	91	60	

HWXOP 3...-T2



Indexable drill shank

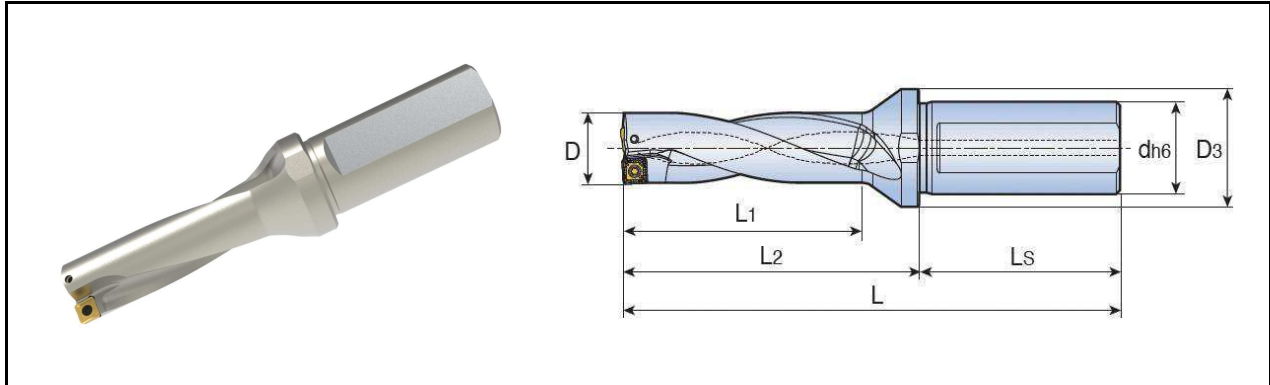

©drilling depth: 3xD(diameter)

product model	dimensions							compatible inserts
	D	d	D3	L	L1	L2	Ls	
HWXOP 3235-25T2-08	23.5	25	32	150	72	94	56	XOMX 08
HWXOP 3235-32T2-08	23.5	32	40	150	72	94	60	
HWXOP 3240-25T2-08	24.0	25	32	150	72	94	56	
HWXOP 3240-32T2-08	24.0	32	40	154	72	94	60	
HWXOP 3245-25T2-08	24.5	25	32	153	75	97	56	
HWXOP 3245-32T2-08	24.5	32	40	157	75	97	60	
HWXOP 3250-25T2-08	25.0	25	32	153	75	97	56	
HWXOP 3250-32T2-08	25.0	32	40	157	75	97	60	
HWXOP 3254-25T2-08 *	25.4	25	32	153	76.2	97	56	
HWXOP 3255-25T2-08	25.5	25	32	155	78	99	56	
HWXOP 3255-32T2-08	25.5	32	40	159	78	99	60	
HWXOP 3260-25T2-08	26.0	25	32	155	78	99	56	
HWXOP 3260-32T2-08	26.0	32	32	159	78	99	60	
HWXOP 3265-25T2-09	26.5	25	40	160	81	104	56	
HWXOP 3265-32T2-09	26.5	32	40	164	81	104	60	
HWXOP 3270-25T2-09	27.0	25	40	160	81	104	56	
HWXOP 3270-32T2-09	27.0	32	40	164	81	104	60	
HWXOP 3275-25T2-09	27.5	25	40	163	84	107	56	
HWXOP 3275-32T2-09	27.5	32	40	167	84	107	60	
HWXOP 3280-25T2-09	28.0	25	40	163	84	107	56	
HWXOP 3280-32T2-09	28.0	32	40	167	84	107	60	
HWXOP 3285-25T2-09	28.5	25	40	166	87	110	56	

©Standard shank with internal coolant

©inserts To be ordered separately

© “*” mark is inch system

©There is no threaded interface at the end of the standard shank

©cooling hole plug for lathe. To be ordered separately

HWXOP 3...-T2



Indexable drill shank

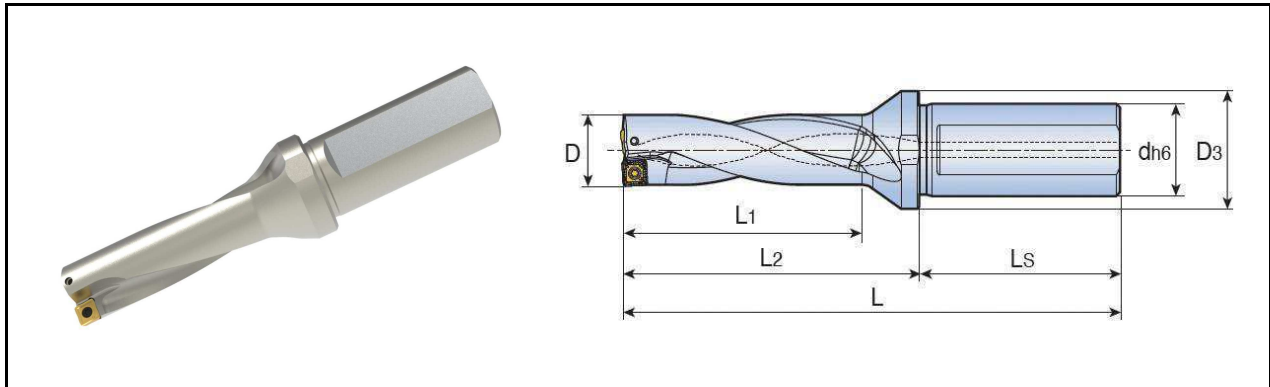

©drilling depth: 3xD(diam)

product model	dimensions							compatible inserts
	D	d	D3	L	L1	L2	Ls	
HWXOP 3285-32T2-09	28.5	32	40	170	87	110	60	XOMX 09
HWXOP 3290-25T2-09	29.0	25	40	166	87	110	56	
HWXOP 3290-32T2-09	29.0	32	40	170	87	110	60	
HWXOP 3295-32T2-09	29.5	32	40	173	90	113	60	
HWXOP 3300-32T2-09	30.0	32	40	173	90	113	60	
HWXOP 3305-32T2-09	30.5	32	40	176	93	116	60	
HWXOP 3310-32T2-09	31.0	32	40	176	93	116	60	
HWXOP 3320-32T2-11	32.0	32	40	179	96	119	60	XOMX 11
HWXOP 3320-40T2-11	32.0	40	50	189	96	119	70	
HWXOP 3330-32T2-11	33.0	32	40	182	99	122	60	
HWXOP 3330-40T2-11	33.0	40	50	192	99	122	70	
HWXOP 3340-32T2-11	34.0	32	40	185	102	125	60	
HWXOP 3340-40T2-11	34.0	40	50	195	102	125	70	
HWXOP 3350-32T2-11	35.0	32	40	188	105	128	60	
HWXOP 3350-40T2-11	35.0	40	50	198	105	128	70	XOMX 13
HWXOP 3360-32T2-11	36.0	32	40	191	108	131	60	
HWXOP 3360-40T2-11	36.0	40	50	201	108	131	70	
HWXOP 3370-32T2-13	37.0	32	50	199	111	139	60	
XOP 3370-40T2-13	37.0	40	50	209	111	139	70	
XOP 3380-32T2-13	38.0	32	50	202	114	142	60	
XOP 3380-40T2-13	38.0	40	50	212	114	142	70	
XOP 3390-32T2-13	39.0	32	50	205	117	145	60	XOMX 13
XOP 3390-40T2-13	39.0	40	50	215	117	145	70	
XOP 3400-32T2-13	40.0	32	50	208	120	148	60	
XOP 3400-40T2-13	40.0	40	40	218	120	148	70	

HWXOP 3...-T2



Indexable drill shank

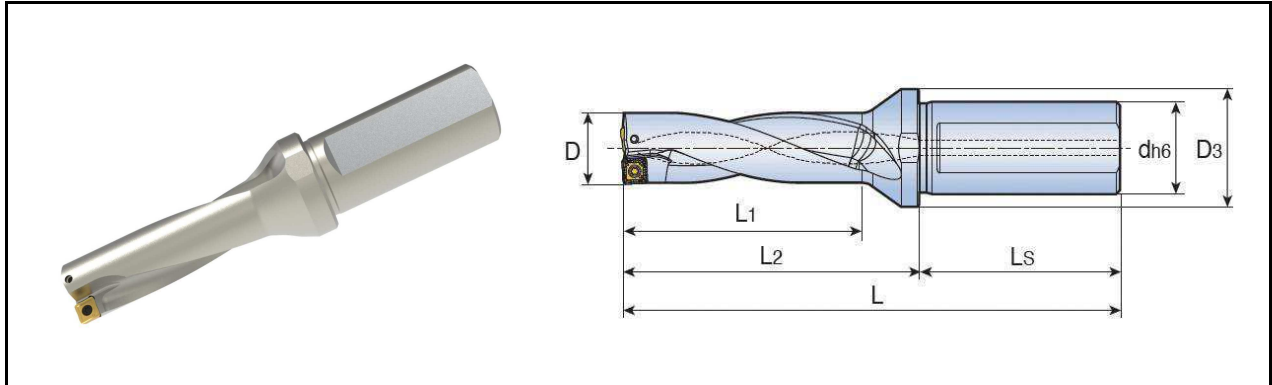

©drilling depth: 3xD(diameter)

product model	dimensions							compatible inserts
	D	d	D3	L	L1	L2	Ls	
HWXOP 3410-40T2-13	41.0	40	50	221	123	151	70	XOMX 13
HWXOP 3420-40T2-13	42.0	40	50	224	126	154	70	
HWXOP 3430-40T2-13	43.0	40	50	227	129	157	70	
HWXOP 3440-40T2-15	44.0	40	60	237	132	167	70	XOMX 15
HWXOP 3450-40T2-15	45.0	40	60	240	135	170	70	
HWXOP 3460-40T2-15	46.0	40	60	243	138	173	70	
HWXOP 3470-40T2-15	47.0	40	60	246	141	176	70	
HWXOP 3480-40T2-15	48.0	40	60	249	144	179	70	
HWXOP 3490-40T2-15	49.0	40	60	252	147	182	70	
HWXOP 3500-40T2-15	50.0	40	60	255	150	185	70	

©Standard shank with internal coolant

©inserts To be ordered separately

©There is no threaded interface at the end of the standard s

©cooling hole plug for lathe . T . b . o . s

accessory

product model	screw	wrench	cooling hole plug	备注
HWXOP. 3140-4160	CSG2049-P	CTS06W-P	CSL 20	◎:cooling hole plug for lathe , to be ordred separately ◎:*cooling hole plug for lathe . model according to shank dia . if diameter 32mm, then cooling hole plug for lathe . model CSL 32
HWXOP. 3165-4220	CSG2252-P	CTS07W-P	CSL 25	
HWXOP. 3225-4260	CSG2565-P	CTS08W-P	CSL 25/CSL 32	
HWXOP. 3265-4360	CSG3585-P	CTS10W-P	CSL 25/CSL 32	
HWXOP. 3370-4430	CSG4011-P	CTS15W-P	CSL 32/CSL 40	
HWXOP. 3440-4508	CSG5012-P	CTS20W-P	CSL 32/CSL 40	

HWXOP 5. . -T2



Indexable drill shank

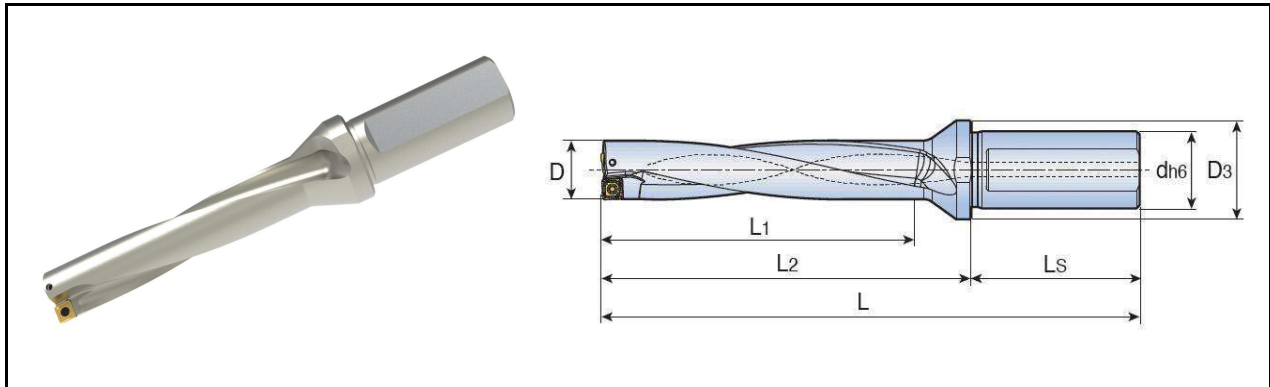

©drilling depth: 5xD(diameter)

product model	dimensions							compatible inserts
	D	d	D3	L	L1	L2	Ls	
HWXOP 5140-20T2-05	14.0	20	25	138	70	88	50	XOMX 05
HWXOP 5145-20T2-05	14.5	20	25	144	75	94	50	
HWXOP 5150-20T2-05	15.0	20	25	144	75	94	50	
HWXOP 5155-20T2-05	15.5	20	25	150	80	100	50	
HWXOP 5160-20T2-05	16.0	20	25	150	80	100	50	
HWXOP 5165-25T2-06	16.5	25	32	161	85	105	56	XOMX 06
HWXOP 5170-25T2-06	17.0	25	32	161	85	105	56	
HWXOP 5175-25T2-06	17.5	25	32	167	90	111	56	
HWXOP 5180-25T2-06	18.0	25	32	167	90	111	56	
HWXOP 5185-25T2-06	18.5	25	32	172	95	116	56	
HWXOP 5190-25T2-06	19.0	25	32	172	95	116	56	XOMX 07
HWXOP 5195-25T2-07	19.5	25	32	179	100	123	56	
HWXOP 5200-25T2-07	20.0	25	32	179	100	123	56	
HWXOP 5205-25T2-07	20.5	25	32	184	105	128	56	
HWXOP 5210-25T2-07	21.0	25	32	184	105	128	56	
HWXOP 5215-25T2-07	21.5	25	32	189	110	133	56	XOMX 08
HWXOP 5220-25T2-07	22.0	25	32	189	110	133	56	
HWXOP 5222-25T2-07 *	22.2	25	32	189	111	133	56	
HWXOP 5225-25T2-08	22.5	25	32	193	115	137	56	
HWXOP 5230-25T2-08	23.0	25	32	193	115	137	56	
HWXOP 5230-32T2-08	23.0	32	40	197	115	137	60	XOMX 08
HWXOP 5235-25T2-08	23.5	25	32	198	120	142	56	

©Standard shank with internal coolant

©inserts To be ordered separately

© “*” mark is inch system

©There is no threaded interface at the end of the standard shank

©cooling hole plug for lathe. To be ordered separately

XOP 5. . -T2



Indexable drill shank

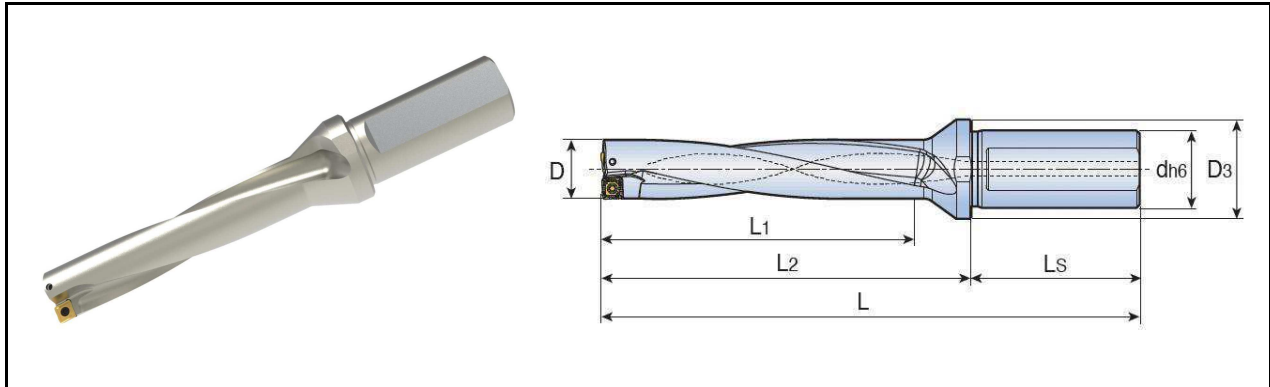

©drilling depth: 5xD(diameter)

product model	dimensions							compatible inserts	
	D	d	D3	L	L1	L2	Ls		
HWXOP 5235-32T2-08	23.5	32	40	202	120	142	60	XOMX 08	
HWXOP 5240-25T2-08	24.0	25	32	198	120	142	56		
HWXOP 5240-32T2-08	24.0	32	40	202	120	142	60		
HWXOP 5245-25T2-08	24.5	25	32	203	125	147	56		
HWXOP 5245-32T2-08	24.5	32	40	207	125	147	60		
HWXOP 5250-25T2-08	25.0	25	32	203	125	147	56		
HWXOP 5250-32T2-08	25.0	32	40	207	125	147	60		
HWXOP 5255-25T2-08	25.5	25	32	207	130	151	56		
HWXOP 5255-32T2-08	25.5	32	40	211	130	151	60		
HWXOP 5260-25T2-08	26.0	25	32	207	130	151	56		
HWXOP 5260-32T2-08	26.0	32	40	211	130	151	60		
HWXOP 5265-32T2-09	26.5	32	40	218	135	158	60		XOMX 09
HWXOP 5270-25T2-09	27.0	25	40	214	135	158	56		
HWXOP 5270-32T2-09	27.0	32	40	218	135	158	60		
HWXOP 5275-32T2-09	27.5	32	40	223	140	163	60		
HWXOP 5280-25T2-09	28.0	25	40	219	140	163	56		
HWXOP 5280-32T2-09	28.0	32	40	223	140	163	60		
HWXOP 5282-32T2-09 *	28.2	32	40	223	141	163	60		
HWXOP 5285-32T2-09	28.5	32	40	228	145	168	60		
HWXOP 5290-25T2-09	29.0	25	40	224	145	168	56		
HWXOP 5290-32T2-09	29.0	32	40	228	145	168	60		
HWXOP 5295-32T2-09	29.5	32	40	233	150	173	60		
HWXOP 5300-32T2-09	30.0	32	40	233	150	173	60		
HWXOP 5305-32T2-09	30.5	32	40	238	155	178	60		
HWXOP 5310-32T2-09	31.0	32	40	238	155	178	60		

XOP 5. . -T2



Indexable drill shank

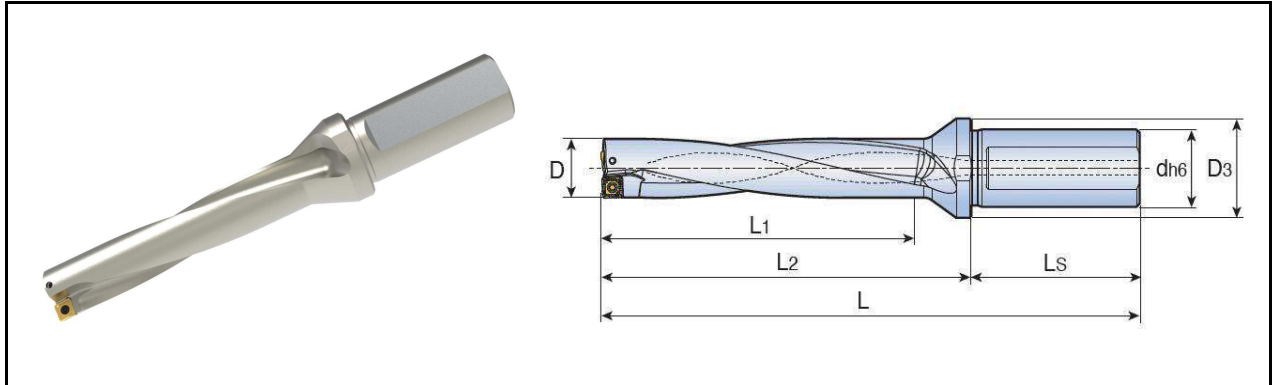

©drilling depth: 5xD(diam)

product model	DIMENSION							compatible inserts
	D	d	D3	L	L1	L2	Ls	
HWXOP 5320-32T2-11	32.0	32	40	243	160	183	60	XOMX 11
HWXOP 5320-40T2-11	32.0	40	50	253	160	183	70	
HWXOP 5330-32T2-11	33.0	32	40	248	165	188	60	
HWXOP 5330-40T2-11	33.0	40	50	258	165	188	70	
HWXOP 5340-32T2-11	34.0	32	40	253	170	193	60	
HWXOP 5340-40T2-11	34.0	40	50	263	170	193	70	
HWXOP 5350-32T2-11	35.0	32	40	258	175	198	60	
HWXOP 5350-40T2-11	35.0	40	50	268	175	198	70	
HWXOP 5360-32T2-11	36.0	32	40	263	180	203	60	
HWXOP 5360-40T2-11	36.0	40	50	273	180	203	70	
HWXOP 5370-32T2-13	37.0	32	50	273	185	213	60	XOMX 13
HWXOP 5370-40T2-13	37.0	40	50	283	185	213	70	
HWXOP 5380-32T2-13	38.0	32	50	278	190	218	60	
HWXOP 5380-40T2-13	38.0	40	50	288	190	218	70	
HWXOP 5390-32T2-13	39.0	32	50	283	195	223	60	
HWXOP 5390-40T2-13	39.0	40	50	293	195	223	70	
HWXOP 5400-32T2-13	40.0	32	50	288	200	228	60	
HWXOP 5400-40T2-13	40.0	40	50	298	200	228	70	
HWXOP 5410-40T2-13	41.0	40	50	303	205	233	70	
HWXOP 5420-40T2-13	42.0	40	50	308	210	238	70	
HWXOP 5430-40T2-13	43.0	40	50	313	215	243	70	XOMX 15
HWXOP 5440-40T2-15	44.0	40	60	325	220	255	70	
HWXOP 5450-40T2-15	45.0	40	60	330	225	260	70	

©Standard shank with internal coolant

©inserts To be ordered separately

©There is no threaded interface at the end of the standard shank

©cooling hole plug for lathe. To be ordered separately

XOP 5. . -T2



Indexable drill shank

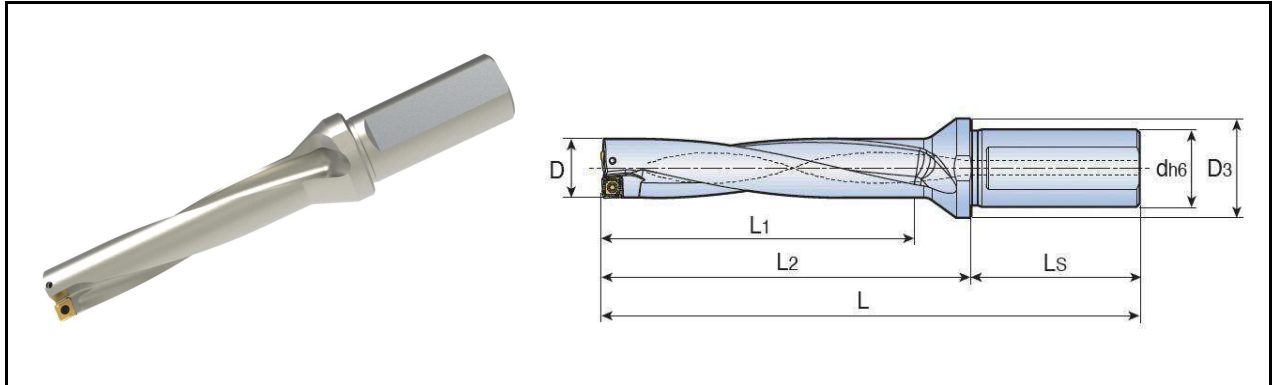

©drilling depth: 5xD(diameter)

product model	dimensions							compatible inserts
	D	d	D3	L	L1	L2	Ls	
HWXOP 5460-40T2-15	46.0	40	60	335	230	265	70	XOMX 15
HWXOP 5470-40T2-15	47.0	40	60	340	235	270	70	
HWXOP 5480-40T2-15	48.0	40	60	345	240	275	70	
HWXOP 5490-40T2-15	49.0	40	60	350	245	280	70	
HWXOP 5500-40T2-15	50.0	40	60	355	250	285	70	

©Standard shank with internal coolant

©inserts To be ordered separately

©There is no threaded interface at the end of the standard s

©cooling hole plug for lathe . T . b . o . s

accessory

product model	screw	wrench	cooling hole plug
HWXOP 5140-5160	CSG2049-P	CTS06W-P	CSL 20
HWXOP 5165-5220	CSG2252-P	CTS07W-P	CSL 25
HWXOP 5225-5260	CSG2565-P	CTS08W-P	CSL 25/CSL 32
HWXOP 5265-5360	CSG3585-P	CTS10W-P	CSL 25/CSL 32
HWXOP 5370-5430	CSG4011-P	CTS15W-P	CSL 32/CSL 40
HWXOP 5440-5500	CSG5012-P	CTS20W-P	CSL 32/CSL 40

©:cooling hole plug for lathe , to be ordred separately

©*:cooling hole plug for lathe . model according to shank dia, if diameter: 32mm, then cooling hole plug for lathe . model CSL 32

CDR25. . -T2



Indexable cartridge drill shank

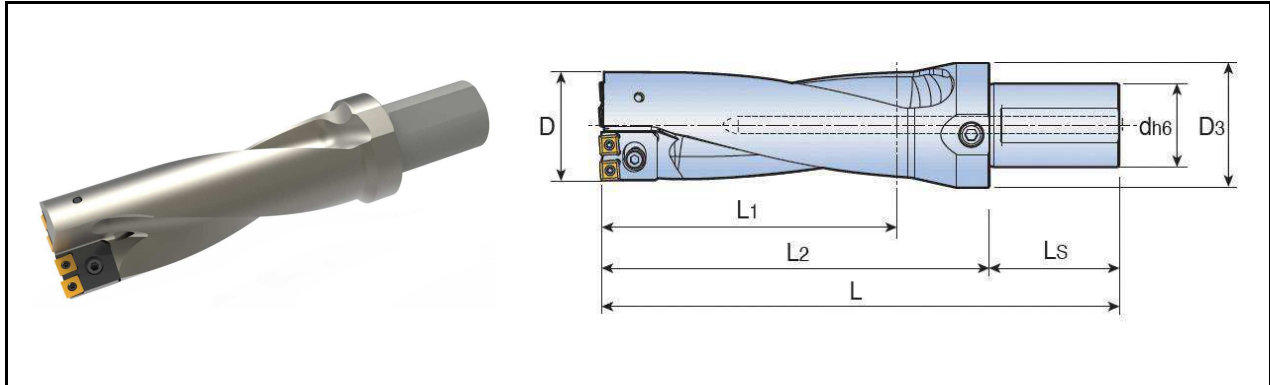

©drilling depth: 2.5xD(diameter)

product model	dimensions							SETTING PLATE	inserts
	D	d	D3	L	L1	L2	Ls		
CDR 2551-53-50T2-07CA-T	51	50	75	250	133	170	80		SPMG. 07
	52	50	75	250	133	170	80	TDP-0701	
	53	50	75	250	133	170	80	TDP-0702	
CDR 2554-56-50T2-07CA-T	54	50	75	260	140	180	80		SPMG. 07
	55	50	75	260	140	180	80	TDP-0701	
	56	50	75	260	140	180	80	TDP-0702	
CDR 2557-62-50T2-09CA-T	57	50	75	281	155	201	80		SPMG. 09
	58	50	75	281	155	201	80	TDP-0901	
	59	50	75	281	155	201	80	TDP-0902	
	60	50	75	281	155	201	80	TDP-0903	
	61	50	75	281	155	201	80	TDP-0904	
CDR 2563-66-50T2-09CA-T	62	50	75	281	155	201	80	TDP-0905	SPMG. 09
	63	50	75	295	165	215	80		
	64	50	75	295	165	215	80	TDP-0901	
	65	50	75	295	165	215	80	TDP-0902	
CDR 2567-73-50T2-11CA-T	66	50	75	295	165	215	80	TDP-0903	SPMG. 11
	67	50	75	320	183	240	80		
	68	50	75	320	183	240	80	TDP-1101	
	69	50	75	320	183	240	80	TDP-1102	
	70	50	75	320	183	240	80	TDP-1103	
	71	50	75	320	183	240	80	TDP-1104	
	72	50	75	320	183	240	80	TDP-1105	
73	50	75	320	183	240	80	TDP-1106		

©Standard shank with internal coolant

©insertsTo be ordered separately

CDR25. . -T2





Indexable clamp drill shank

cutter clamp accessory

clamp model	clamp screw	washer	adj. screw	wrench
CDR 07CA-P1-T	CLA0401607	CQP4380	CSS2005	CTS06W
CDR 07CA-C1-T	CLA0401607	CQP4380		
CDR 07CA-P2-T	CLA0401607	CQP4380	CSS2005	CTS06W
CDR 07CA-C2-T	CLA0401607	CQP4380		
CDR 09CA-P1-T	CLA0501608	CQP5510	CSC3080	CTS10W
CDR 09CA-C1-T	CLA0501608	CQP5510		
CDR 09CA-P2-T	CLA0501608	CQP5510	CSC3080	CTS10W
CDR 09CA-C2-T	CLA0501608	CQP5510		
CDR 11CA-P1-T	CLA0602010	CQP6412	CSC3080	CTS10W
CDR 11CA-C1-T	CLA0602010	CQP6412		

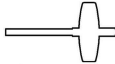
accessory

product model	screw	wrench	EXTER. EDGE SHANK	CENTAL SHANK
				
CDR 2551	CSG2565-P	CTS08W-P	CDR 07CA-P1-T	CDR 07CA-C1-T
CDR 2554	CSG2565-P	CTS08W-P	CDR 07CA-P2-T	CDR 07CA-C2-T
CDR 2557	CSG3585-P	CTS10W-P	CDR 09CA-P1-T	CDR 09CA-C1-T
CDR 2563	CSG4011-P	CTS15W-P	CDR 09CA-P2-T	CDR 09CA-C2-T
CDR 2567	CSG4011-P	CTS15W-P	CDR 11CA-P1-T	CDR 11CA-C1-T

CDR35. . -T2



Indexable cutter clamp drill shank

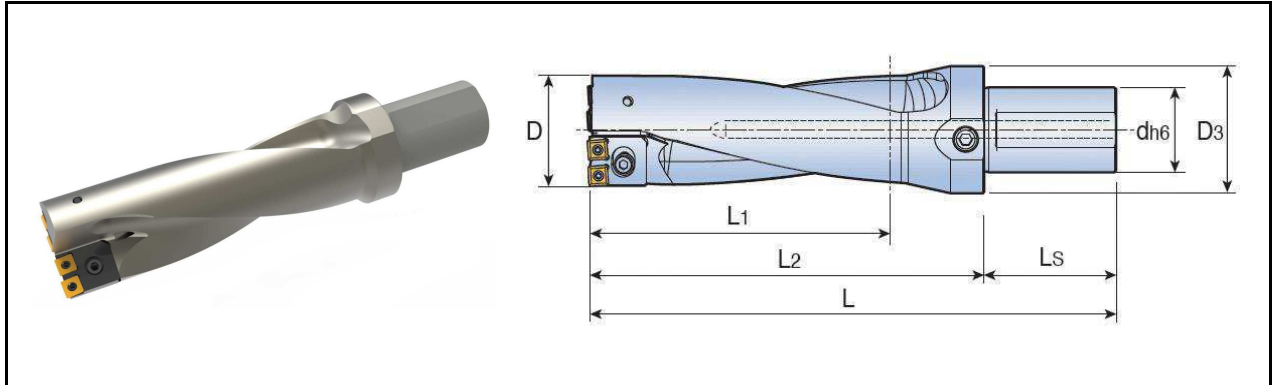

©drilling depth: 3.5xD(diameter)

product model	DIMENSION							SETTING PLATE	inserts model
	D	d	D3	L	L1	L2	Ls		
CDR 3551-53-50T2-07CA-T	51	50	75	303	186	223	80		SPMG. 07
	52	50	75	303	186	223	80	CDR-0701	
	53	50	75	303	186	223	80	CDR-0702	
CDR 3554-56-50T2-07CA-T	54	50	75	316	196	236	80		SPMG. 07
	55	50	75	316	196	236	80	CDR-0701	
	56	50	75	316	196	236	80	CDR-0702	
CDR 3557-62-50T2-09CA-T	57	50	75	343	217	263	80		SPMG. 09
	58	50	75	343	217	263	80	CDR-0901	
	59	50	75	343	217	263	80	CDR-0902	
	60	50	75	343	217	263	80	CDR-0903	
	61	50	75	343	217	263	80	CDR-0904	
	62	50	75	343	217	263	80	CDR-0905	
CDR 3563-66-50T2-09CA-T	63	50	75	361	231	281	80		SPMG. 09
	64	50	75	361	231	281	80	CDR-0901	
	65	50	75	361	231	281	80	CDR-0902	
	66	50	75	361	231	281	80	CDR-0903	
CDR 3567-73-50T2-11CA-T	67	50	75	393	256	313	80		SPMG. 11
	68	50	75	393	256	313	80	CDR-1101	
	69	50	75	393	256	313	80	CDR-1102	
	70	50	75	393	256	313	80	CDR-1103	
	71	50	75	393	256	313	80	CDR-1104	
	72	50	75	393	256	313	80	CDR-1105	
	73	50	75	393	256	313	80	CDR-1106	

©Standard shank with internal coolant

©insertsTo be ordered separately

CDR35. . -T2







Indexable cutter clamp drill shank

cutter clamp accessory

clamp model	utter clamp 锁紧scre	垫圈	SETTING PLATEscrew	
CDR 07CA-P1-T	CLA0401607	CQP4380	CSS2005	CTS06W
CDR 07CA-C1-T	CLA0401607	CQP4380		
CDR 07CA-P2-T	CLA0401607	CQP4380	CSS2005	CTS06W
CDR 07CA-C2-T	CLA0401607	CQP4380		
CDR 09CA-P1-T	CLA0501608	CQP5510	CSC3080	CTS10W
CDR 09CA-C1-T	CLA0501608	CQP5510		
CDR 09CA-P2-T	CLA0501608	CQP5510	CSC3080	CTS10W
CDR 09CA-C2-T	CLA0501608	CQP5510		
CDR 11CA-P1-T	CLA0602010	CQP6412	CSC3080	CTS10W
CDR 11CA-C1-T	CLA0602010	CQP6412		

accessory

product model	screw	wrench	outer edgecutter	中心cutter clamp
				
CDR 3551	CSG2565-P	CTS08W-P	CDR 07CA-P1-T	CDR 07CA-C1-T
CDR 3554	CSG2565-P	CTS08W-P	CDR 07CA-P2-T	CDR 07CA-C2-T
CDR 3557	CSG3585-P	CTS10W-P	CDR 09CA-P1-T	CDR 09CA-C1-T
CDR 3563	CSG3585-P	CTS10W-P	CDR 09CA-P2-T	CDR 09CA-C2-T
CDR 3567	CSG4011-P	CTS15W-P	CDR 11CA-P1-T	CDR 11CA-C1-T

HANWOO

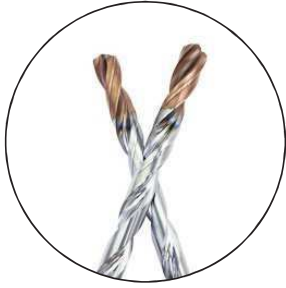

HW...3D



Solid carbide twist drill

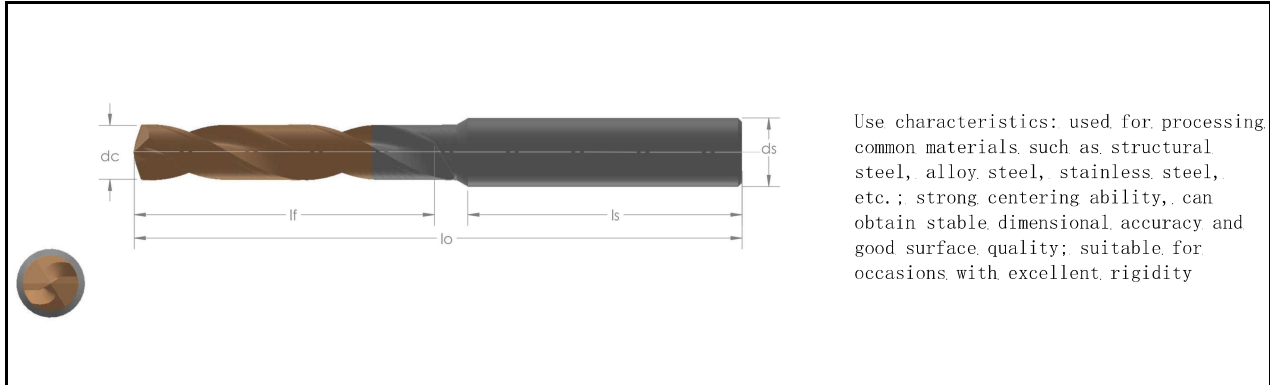

©Solid carbide twist drill: 3xD(DIA); main edge angle: 140°

PRODUCT MODEL	DIMENSION					threaded bottom hole	
	dc	lf	ds	ls	lo	cutting tap	extrusion tap
HW-D033-3D	3.3	20	6	36	62	M4x0.7	—
HW-D034-3D	3.4	20	6	36	62	NO. 8-32UNC	—
HW-D035-3D	3.5	20	6	36	62	M4x0.5 NO. 8-36UNC	—
HW-D036-3D	3.6	20	6	36	62	—	—
HW-D037-3D	3.7	20	6	36	62	—	M4x0.7
HW-D038-3D	3.8	24	6	36	66	—	M4x0.5
HW-D039-3D	3.9	24	6	36	66	NO. 10-24UNC	—
HW-D040-3D	4.0	24	6	36	66	—	—
HW-D041-3D	4.1	24	6	36	66	NO. 10-32UNF	—
HW-D042-3D	4.2	24	6	36	66	M5x0.8	—
HW-D043-3D	4.3	24	6	36	66	—	—
HW-D044-3D	4.4	24	6	36	66	—	—
HW-D045-3D	4.5	24	6	36	66	M5x0.5 NO. 12-24UNC	—
HW-D046-3D	4.6	24	6	36	66	NO. 12-28UNF	M5x0.8
HW-D047-3D	4.7	24	6	36	66	NO. 12-32UNEF	—
HW-D048-3D	4.8	28	6	36	66	—	—
HW-D049-3D	4.9	28	6	36	66	—	—
HW-D050-3D	5.0	28	6	36	66	M6x1	—
HW-D051-3D	5.1	28	6	36	66	1/4-20UNC	—
HW-D052-3D	5.2	28	6	36	66	—	—
HW-D053-3D	5.3	28	6	36	66	M6x0.75	—

©Standard drill without internal coolant

HW...3D



Solid carbide twist drill

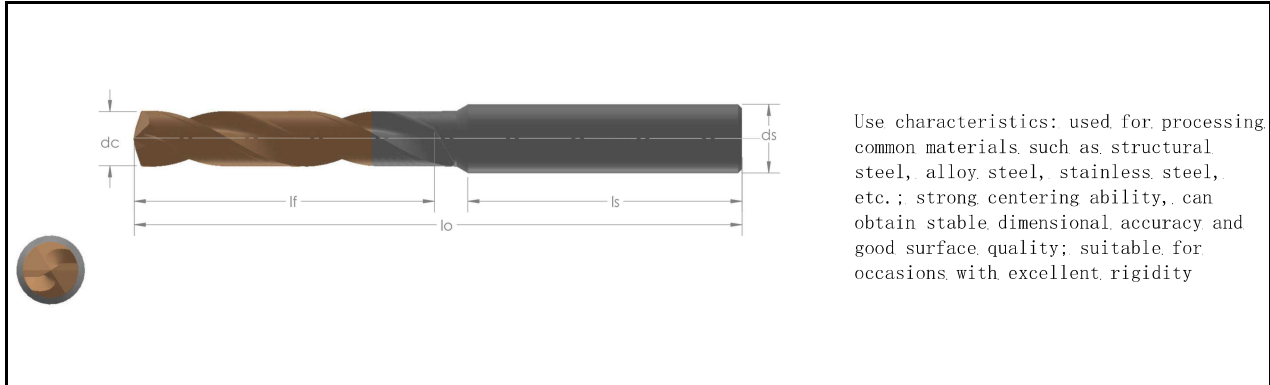

Use characteristics: used for processing common materials such as structural steel, alloy steel, stainless steel, etc.; strong centering ability, can obtain stable dimensional accuracy and good surface quality; suitable for occasions with excellent rigidity

©Solid carbide twist drill: 3xD(DIA); main edge angl

PRODUCT MODEL	DIMENSION					threaded bottom hole	
	dc	lf	ds	ls	lo	cutting tap	extrusion tap
HW-D054-3D	5.4	28	6	36	66	—	—
HW-D055-3D	5.5	28	6	36	66	1/4-28UNF	M6x1
HW-D056-3D	5.6	28	6	36	66	1/4-32UNEF	—
HW-D057-3D	5.7	28	6	36	66	—	—
HW-D058-3D	5.8	28	6	36	66	—	—
HW-D059-3D	5.9	28	6	36	66	—	—
HW-D060-3D	6.0	28	6	36	66	—	—
HW-D061-3D	6.1	34	8	36	79	—	—
HW-D062-3D	6.2	34	8	36	79	—	—
HW-D063-3D	6.3	34	8	36	79	—	—
HW-D064-3D	6.4	34	8	36	79	—	—
HW-D065-3D	6.5	34	8	36	79	—	—
HW-D066-3D	6.6	34	8	36	79	5/16-18UNC	—
HW-D067-3D	6.7	34	8	36	79	—	—
HW-D068-3D	6.8	34	8	36	79	M8x1.25	—
HW-D069-3D	6.9	34	8	36	79	5/16-24UNF	—
HW-D070-3D	7.0	34	8	36	79	M8x1	—
HW-D071-3D	7.1	41	8	36	79	5/16-32UNEF	—
HW-D072-3D	7.2	41	8	36	79	—	—
HW-D073-3D	7.3	41	8	36	79	M8x0.75	—
HW-D074-3D	7.4	41	8	36	79	—	M8x1.25
HW-D075-3D	7.5	41	8	36	79	—	—

©Standard drill without internal coolant

HW...3D



Solid carbide twist drill

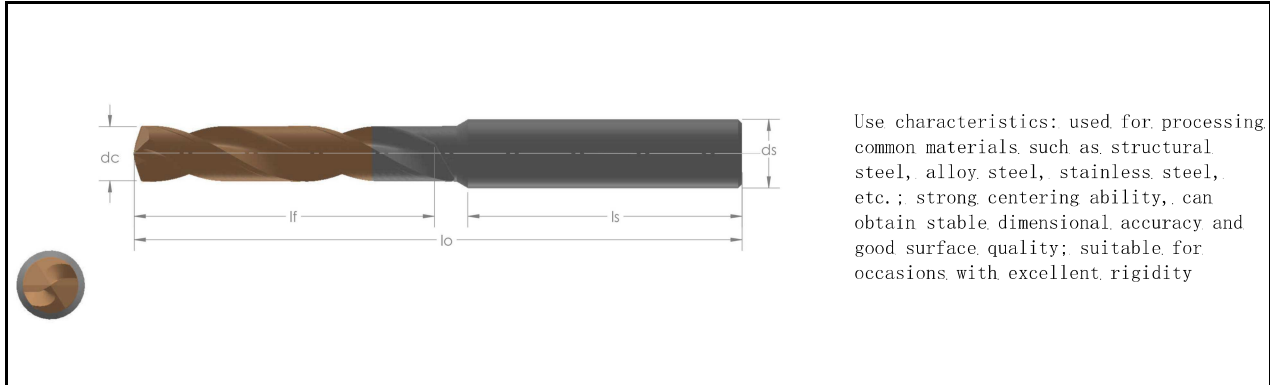

Use characteristics: used for processing common materials such as structural steel, alloy steel, stainless steel, etc.; strong centering ability, can obtain stable dimensional accuracy and good surface quality; suitable for occasions with excellent rigidity

©Solid carbide twist drill: 3xD(DIA); main edge angl

PRODUCT MODEL	DIMENSION					threaded bottom hole	
	dc	lf	ds	ls	lo	cutting tap	extrusion tap
HW-D076-3D	7.6	41	8	36	79	—	—
HW-D077-3D	7.7	41	8	36	79	—	—
HW-D078-3D	7.8	41	8	36	79	—	—
HW-D079-3D	7.9	41	8	36	79	—	—
HW-D080-3D	8.0	41	8	36	79	3/8-16UNC	—
HW-D081-3D	8.1	47	10	40	89	—	—
HW-D082-3D	8.2	47	10	40	89	—	—
HW-D083-3D	8.3	47	10	40	89	—	—
HW-D084-3D	8.4	47	10	40	89	—	—
HW-D085-3D	8.5	47	10	40	89	M10x1.5 3/8-24UNF	—
HW-D086-3D	8.6	47	10	40	89	—	—
HW-D087-3D	8.7	47	10	40	89	3/8-32UNEF	—
HW-D088-3D	8.8	47	10	40	89	M10x1.25	—
HW-D089-3D	8.9	47	10	40	89	—	—
HW-D090-3D	9.0	47	10	40	89	M10x1	—
HW-D091-3D	9.1	47	10	40	89	—	—
HW-D092-3D	9.2	47	10	40	89	—	—
HW-D093-3D	9.3	47	10	40	89	M10x0.75	M10x1.5
HW-D094-3D	9.4	47	10	40	89	7/16-14UNC	—
HW-D095-3D	9.5	47	10	40	89	—	—
HW-D097-3D	9.7	47	10	40	89	—	—
HW-D098-3D	9.8	47	10	40	89	—	—

©Standard drill without internal coolant

HW...3D



Solid carbide twist drill

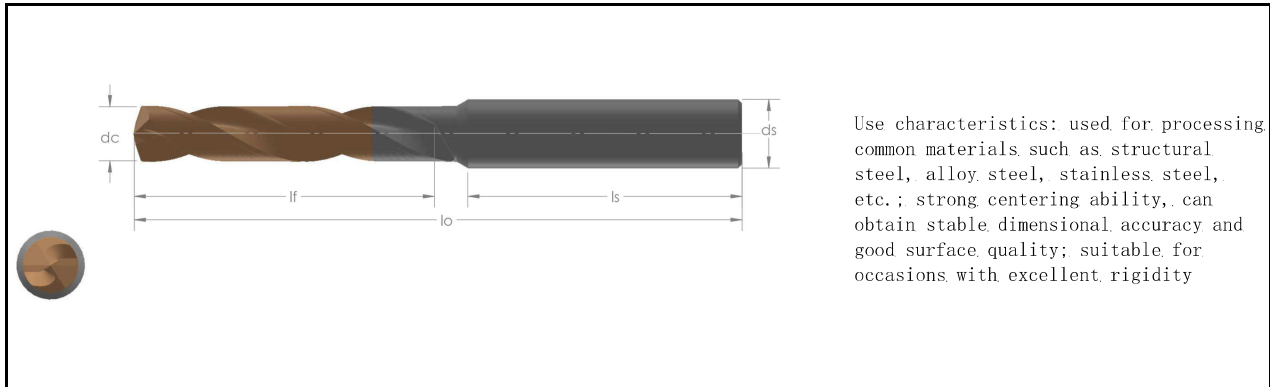

Use characteristics: used for processing common materials such as structural steel, alloy steel, stainless steel, etc.; strong centering ability, can obtain stable dimensional accuracy and good surface quality; suitable for occasions with excellent rigidity

©Solid carbide twist drill: 3xD(DIA); main edge angle

PRODUCT MODEL	DIMENSION					threaded bottom hole	
	dc	lf	ds	ls	lo	cutting tap	extrusion tap
HW-D099-3D	9.9	47	10	40	89	7/16-20UNF	—
HW-D100-3D	10.0	47	10	40	89	—	—
HW-D101-3D	10.1	55	12	45	102	—	—
HW-D102-3D	10.2	55	12	45	102	7/16-28UNEF	—
HW-D103-3D	10.3	55	12	45	102	M12x1.75	—
HW-D104-3D	10.4	55	12	45	102	—	—
HW-D105-3D	10.5	55	12	45	102	—	—
HW-D106-3D	10.6	55	12	45	102	—	—
HW-D107-3D	10.7	55	12	45	102	—	—
HW-D108-3D	10.8	55	12	45	102	—	—
HW-D109-3D	10.9	55	12	45	102	1/2-13UNC	—
HW-D110-3D	11.0	55	12	45	102	M12x1	—
HW-D111-3D	11.1	55	12	45	102	—	—
HW-D112-3D	11.2	55	12	45	102	—	M12x1.75
HW-D113-3D	11.3	55	12	45	102	—	—
HW-D114-3D	11.4	55	12	45	102	—	—
HW-D115-3D	11.5	55	12	45	102	1/2-20UNF	—
HW-D116-3D	11.6	55	12	45	102	—	—
HW-D117-3D	11.7	55	12	45	102	—	—
HW-D118-3D	11.8	55	12	45	102	1/2-28UNEF	—
HW-D119-3D	11.9	55	12	45	102	—	—
HW-D120-3D	12.0	55	12	45	102	M14x2	—

©Standard drill without internal coolant

HW...3D



Solid carbide twist drill

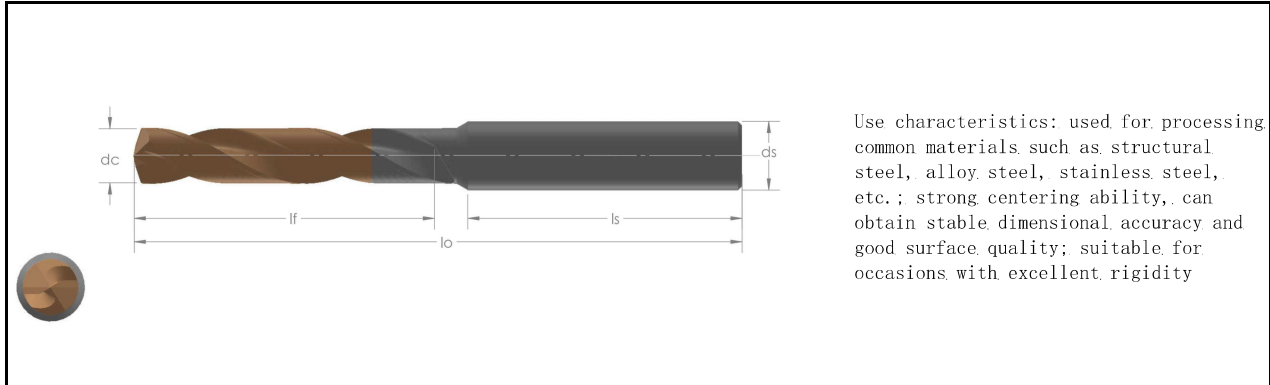

Use characteristics: used for processing common materials such as structural steel, alloy steel, stainless steel, etc.; strong centering ability, can obtain stable dimensional accuracy and good surface quality; suitable for occasions with excellent rigidity

©Solid carbide twist drill: 3xD(DIA); main edge angle

PRODUCT MODEL	DIMENSION					threaded bottom hole	
	dc	lf	ds	ls	lo	cutting tap	extrusion tap
HW-D121-3D	12.1	60	14	45	107	—	—
HW-D122-3D	12.2	60	14	45	107	9/16-12UNC	—
HW-D123-3D	12.3	60	14	45	107	—	—
HW-D124-3D	12.4	60	14	45	107	—	—
HW-D125-3D	12.5	60	14	45	107	M14x1.5	—
HW-D126-3D	12.6	60	14	45	107	—	—
HW-D127-3D	12.7	60	14	45	107	—	—
HW-D128-3D	12.8	60	14	45	107	—	—
HW-D129-3D	12.9	60	14	45	107	9/16-18UNF	—
HW-D130-3D	13.0	60	14	45	107	M14x1	M14x2
HW-D131-3D	13.1	60	14	45	107	—	—
HW-D132-3D	13.2	60	14	45	107	9/16-24UNEF	—
HW-D133-3D	13.3	60	14	45	107	—	—
HW-D134-3D	13.4	60	14	45	107	—	—
HW-D135-3D	13.5	60	14	45	107	—	—
HW-D136-3D	13.6	60	14	45	107	5/8-11UNC	—
HW-D137-3D	13.7	60	14	45	107	—	—
HW-D138-3D	13.8	60	14	45	107	—	—
HW-D139-3D	13.9	60	14	45	107	—	—
HW-D140-3D	14.0	60	14	45	107	M16x2	—
HW-D141-3D	14.1	65	16	48	115	—	—
HW-D142-3D	14.2	65	16	48	115	—	—
HW-D143-3D	14.3	65	16	48	115	—	—

©Standard drill without internal coolant

HW...3D



Solid carbide twist drill

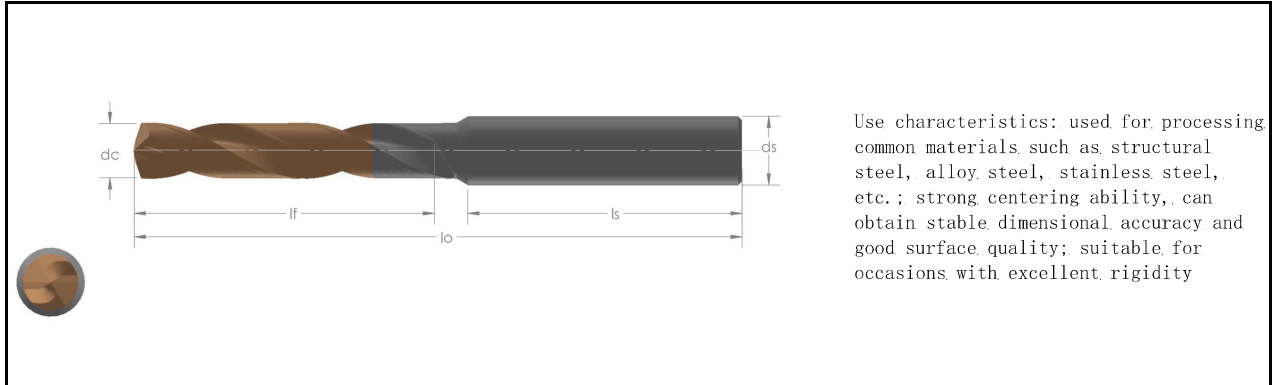

Use characteristics: used for processing common materials such as structural steel, alloy steel, stainless steel, etc.; strong centering ability, can obtain stable dimensional accuracy and good surface quality; suitable for occasions with excellent rigidity

©Solid carbide twist drill: 3xD(DIA); main edge angl

PRODUCT MODEL	DIMENSION					threaded bottom hole	
	dc	lf	ds	ls	lo	cutting tap	extrusion tap
HW-D144-3D	14.4	65	16	48	115	—	—
HW-D145-3D	14.5	65	16	48	115	M16x1.5	—
HW-D145-3D	14.5	65	16	48	115	5/8-18UNF	—
HW-D146-3D	14.6	65	16	48	115	—	—
HW-D147-3D	14.7	65	16	48	115	—	—
HW-D148-3D	14.8	65	16	48	115	5/8-24UNEF	—
HW-D149-3D	14.9	65	16	48	115	—	—
HW-D150-3D	15.0	65	16	48	115	M16x1	M16x2
HW-D151-3D	15.1	65	16	48	115	—	—
HW-D152-3D	15.2	65	16	48	115	—	—
HW-D153-3D	15.3	65	16	48	115	—	—
HW-D154-3D	15.4	65	16	48	115	—	—
HW-D155-3D	15.5	65	16	48	115	M18x2.5	—
HW-D156-3D	15.6	65	16	48	115	—	—
HW-D157-3D	15.7	65	16	48	115	—	—
HW-D158-3D	15.8	65	16	48	115	—	—
HW-D159-3D	15.9	65	16	48	115	—	—
HW-D160-3D	16.0	65	16	48	115	M18x2	—

©Standard drill without internal coolant

HW...5D

Solid carbide twist drill

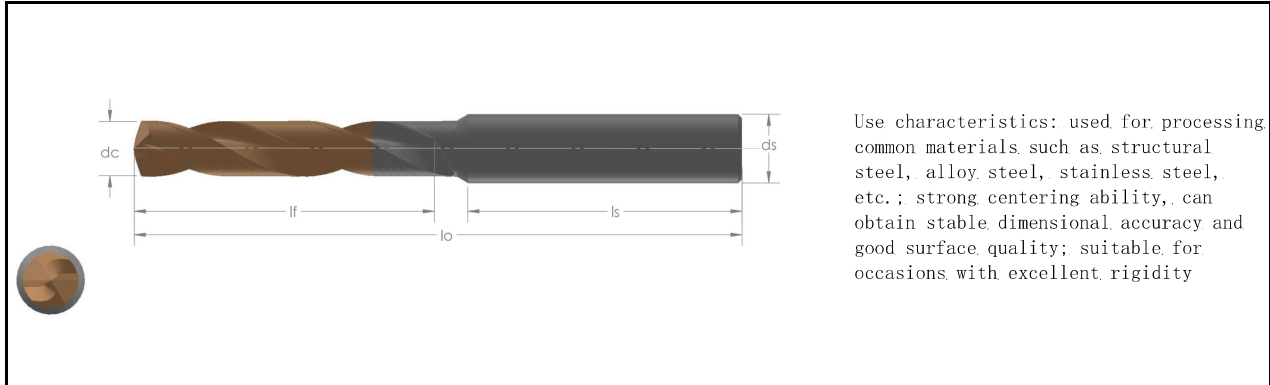

Use characteristics: used for processing common materials such as structural steel, alloy steel, stainless steel, etc.; strong centering ability, can obtain stable dimensional accuracy and good surface quality; suitable for occasions with excellent rigidity

©Solid carbide twist drill: 5xD(DIA); main edge angl

PRODUCT MODEL	DIMENSION					threaded bottom hole	
	dc	lf	ds	ls	lo	cutting tap	extrusion tap
HW-D033-5D	3.3	28	6	36	66	M4×0.7	—
HW-D034-5D	3.4	28	6	36	66	No. 8-32UNC	—
HW-D035-5D	3.5	28	6	36	66	M4×0.5 No. 8-36UNF	—
HW-D036-5D	3.6	28	6	36	66	—	—
HW-D037-5D	3.7	28	6	36	66	—	M4×0.7
HW-D038-5D	3.8	36	6	36	74	—	M4×0.5
HW-D039-5D	3.9	36	6	36	74	No. 10-24UNC	—
HW-D040-5D	4.0	36	6	36	74	—	—
HW-D041-5D	4.1	36	6	36	74	No. 10-32UNF	—
HW-D042-5D	4.2	36	6	36	74	M5×0.8	—
HW-D043-5D	4.3	36	6	36	74	—	—
HW-D044-5D	4.4	36	6	36	74	—	—
HW-D045-5D	4.5	36	6	36	74	M5×0.5 No. 12-24UNC	—
HW-D046-5D	4.6	36	6	36	74	No. 12-28UNF	M5×0.8
HW-D047-5D	4.7	36	6	36	74	No. 12-32UNEF	—
HW-D048-5D	4.8	44	6	36	82	—	—
HW-D049-5D	4.9	44	6	36	82	—	—
HW-D050-5D	5.0	44	6	36	82	M6×1	—
HW-D051-5D	5.1	44	6	36	82	1/4-20UNC	—
HW-D052-5D	5.2	44	6	36	82	—	—
HW-D053-5D	5.3	44	6	36	82	M6×0.75	—

©Standard drill without internal coolant

HW...5D



Solid carbide twist drill

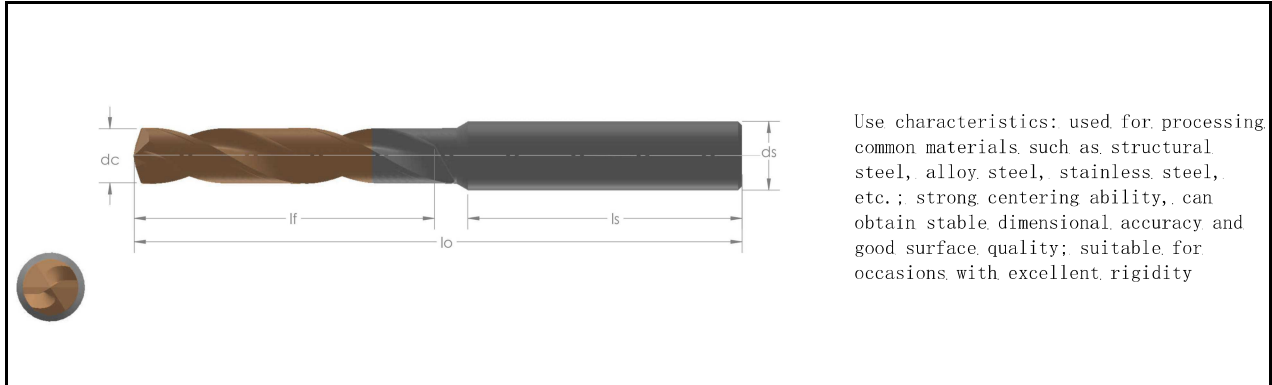

Use characteristics: used for processing common materials such as structural steel, alloy steel, stainless steel, etc.; strong centering ability, can obtain stable dimensional accuracy and good surface quality; suitable for occasions with excellent rigidity

©Solid carbide twist drill: 5xD(DIA); main edge angl

PRODUCT MODEL	DIMENSION					threaded bottom hole	
	dc	lf	ds	ls	lo	cutting tap	extrusion tap
HW-D054-5D	5.4	44	6	36	82	—	—
HW-D055-5D	5.5	44	6	36	82	1/4-28UNF	M6×1
HW-D056-5D	5.6	44	6	36	82	1/4-32UNEF	—
HW-D057-5D	5.7	44	6	36	82	—	—
HW-D058-5D	5.8	44	6	36	82	—	—
HW-D059-5D	5.9	44	6	36	82	—	—
HW-D060-5D	6.0	44	6	36	82	—	—
HW-D061-5D	6.1	53	8	36	91	—	—
HW-D062-5D	6.2	53	8	36	91	—	—
HW-D063-5D	6.3	53	8	36	91	—	—
HW-D064-5D	6.4	53	8	36	91	—	—
HW-D065-5D	6.5	53	8	36	91	—	—
HW-D066-5D	6.6	53	8	36	91	5/16-18UNC	—
HW-D067-5D	6.7	53	8	36	91	—	—
HW-D068-5D	6.8	53	8	36	91	M8×1.25	—
HW-D069-5D	6.9	53	8	36	91	5/16-24UNEF	—
HW-D070-5D	7.0	53	8	36	91	M8×1	—
HW-D071-5D	7.1	53	8	36	91	5/16-32UNEF	—
HW-D072-5D	7.2	53	8	36	91	—	—
HW-D073-5D	7.3	53	8	36	91	M8×0.75	—
HW-D074-5D	7.4	53	8	36	91	—	M8×1.25
HW-D075-5D	7.5	53	8	36	91	—	—
HW-D076-5D	7.6	53	8	36	91	—	—

©Standard drill without internal coolant

HW...5D



Solid carbide twist drill

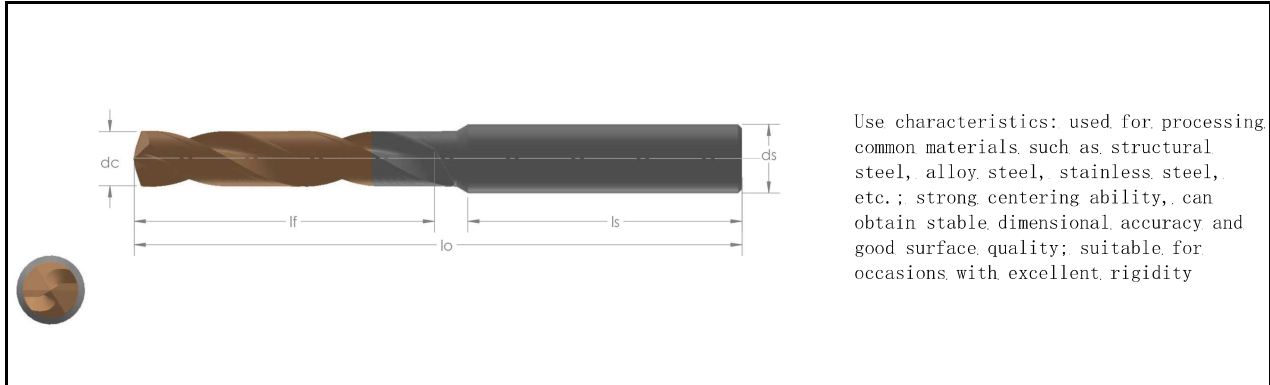

Use characteristics: used for processing common materials such as structural steel, alloy steel, stainless steel, etc.; strong centering ability, can obtain stable dimensional accuracy and good surface quality; suitable for occasions with excellent rigidity

©Solid carbide twist drill: 5xD(DIA); main edge angle

PRODUCT MODEL	DIMENSION					threaded bottom hole	
	dc	lf	ds	ls	lo	cutting tap	extrusion tap
HW-D077-5D	7.7	53	8	36	91	—	—
HW-D078-5D	7.8	53	8	36	91	—	—
HW-D079-5D	7.9	53	8	36	91	—	—
HW-D080-5D	8.0	53	8	36	91	3/8-16UNC	—
HW-D081-5D	8.1	61	10	40	103	—	—
HW-D082-5D	8.2	61	10	40	103	—	—
HW-D083-5D	8.3	61	10	40	103	—	—
HW-D084-5D	8.4	61	10	40	103	—	—
HW-D085-5D	8.5	61	10	40	103	M10×1.5 3/8-24UNF	—
HW-D086-5D	8.6	61	10	40	103	—	—
HW-D087-5D	8.7	61	10	40	103	3/8-32UNEF	—
HW-D088-5D	8.8	61	10	40	103	M10×1.25	—
HW-D089-5D	8.9	61	10	40	103	—	—
HW-D090-5D	9.0	61	10	40	103	M10×1	—
HW-D091-5D	9.1	61	10	40	103	—	—
HW-D092-5D	9.2	61	10	40	103	—	—
HW-D093-5D	9.3	61	10	40	103	M10×0.75	M10×1.5
HW-D094-5D	9.4	61	10	40	103	7/16-14UNC	—
HW-D095-5D	9.5	61	10	40	103	—	—
HW-D096-5D	9.6	61	10	40	103	—	—
HW-D097-5D	9.7	61	10	40	103	—	—
HW-D098-5D	9.8	61	10	40	103	—	—
HW-D099-5D	9.9	61	10	40	103	7/16-20UNF	—

©Standard drill without internal coolant

HW...5D



Solid carbide twist drill

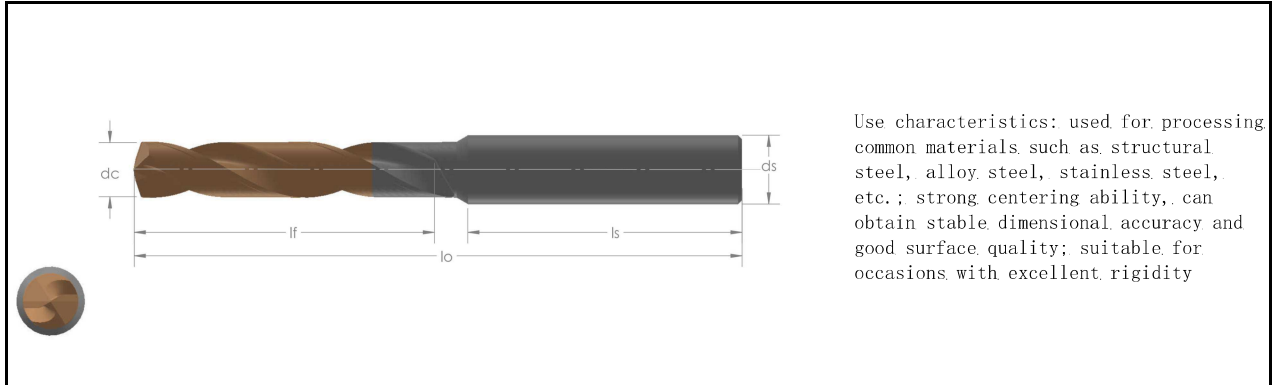

Use characteristics: used for processing common materials such as structural steel, alloy steel, stainless steel, etc.; strong centering ability, can obtain stable dimensional accuracy and good surface quality; suitable for occasions with excellent rigidity

©Solid carbide twist drill: 5xD(DIA); main edge angle

PRODUCT MODEL	DIMENSION					threaded bottom hole	
	dc	lf	ds	ls	lo	cutting tap	extrusion tap
HW-D100-5D	10.0	61	10	40	103	—	—
HW-D101-5D	10.1	71	12	45	118	—	—
HW-D102-5D	10.2	71	12	45	118	7/16-28UNEF	—
HW-D103-5D	10.3	71	12	45	118	M12×1.75	—
HW-D104-5D	10.4	71	12	45	118	—	—
HW-D105-5D	10.5	71	12	45	118	—	—
HW-D106-5D	10.6	71	12	45	118	—	—
HW-D107-5D	10.7	71	12	45	118	—	—
HW-D108-5D	10.8	71	12	45	118	—	—
HW-D109-5D	10.9	71	12	45	118	1/2-13UNC	—
HW-D110-5D	11.0	71	12	45	118	M12×1	—
HW-D111-5D	11.1	71	12	45	118	—	—
HW-D112-5D	11.2	71	12	45	118	—	M12×1.75
HW-D113-5D	11.3	71	12	45	118	—	—
HW-D114-5D	11.4	71	12	45	118	—	—
HW-D115-5D	11.5	71	12	45	118	1/2-20UNF	—
HW-D116-5D	11.6	71	12	45	118	—	—
HW-D117-5D	11.7	71	12	45	118	—	—
HW-D118-5D	11.8	71	12	45	118	1/2-28UNEF	—
HW-D119-5D	11.9	71	12	45	118	—	—
HW-D120-5D	12.0	71	12	45	118	M14×2	—
HW-D121-5D	12.1	77	14	45	124	—	—
HW-D122-5D	12.2	77	14	45	124	9/16-12UNC	—

©Standard drill, without internal coolant

HW...5D



Solid carbide twist drill

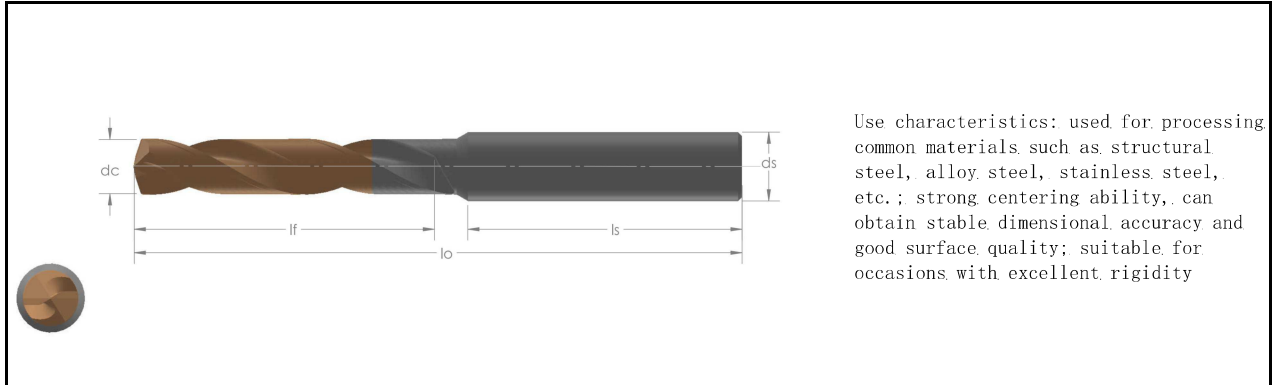

Use characteristics: used for processing common materials such as structural steel, alloy steel, stainless steel, etc.; strong centering ability, can obtain stable dimensional accuracy and good surface quality; suitable for occasions with excellent rigidity

©Solid carbide twist drill: 5xD(DIA); main edge angl

PRODUCT MODEL	DIMENSION					threaded bottom hole	
	dc	lf	ds	ls	lo	cutting tap	extrusion tap
HW-D123-5D	12.3	77	14	45	124	—	—
HW-D124-5D	12.4	77	14	45	124	—	—
HW-D125-5D	12.5	77	14	45	124	M14×1.5	—
HW-D126-5D	12.6	77	14	45	124	—	—
HW-D127-5D	12.7	77	14	45	124	—	—
HW-D128-5D	12.8	77	14	45	124	—	—
HW-D129-5D	12.9	77	14	45	124	9/16-18UNF	—
HW-D130-5D	13.0	77	14	45	124	M14×1	M14×2
HW-D131-5D	13.1	77	14	45	124	—	—
HW-D132-5D	13.2	77	14	45	124	9/16-24UNEF	—
HW-D133-5D	13.3	77	14	45	124	—	—
HW-D134-5D	13.4	77	14	45	124	—	—
HW-D135-5D	13.5	77	14	45	124	—	—
HW-D136-5D	13.6	77	14	45	124	5/8-11UNC	—
HW-D137-5D	13.7	77	14	45	124	—	—
HW-D138-5D	13.8	77	14	45	124	—	—
HW-D139-5D	13.9	77	14	45	124	—	—
HW-D140-5D	14.0	77	14	45	124	M16×2	—
HW-D141-5D	14.1	83	16	48	133	—	—
HW-D142-5D	14.2	83	16	48	133	—	—
HW-D143-5D	14.3	83	16	48	133	—	—
HW-D144-5D	14.4	83	16	48	133	—	—
HW-D145-5D	14.5	83	16	48	133	M16×1.5	—
HW-D145-5D	14.5	83	16	48	133	5/8-18UNF	—

©Standard drill without internal coolant

HW...5D



Solid carbide twist drill

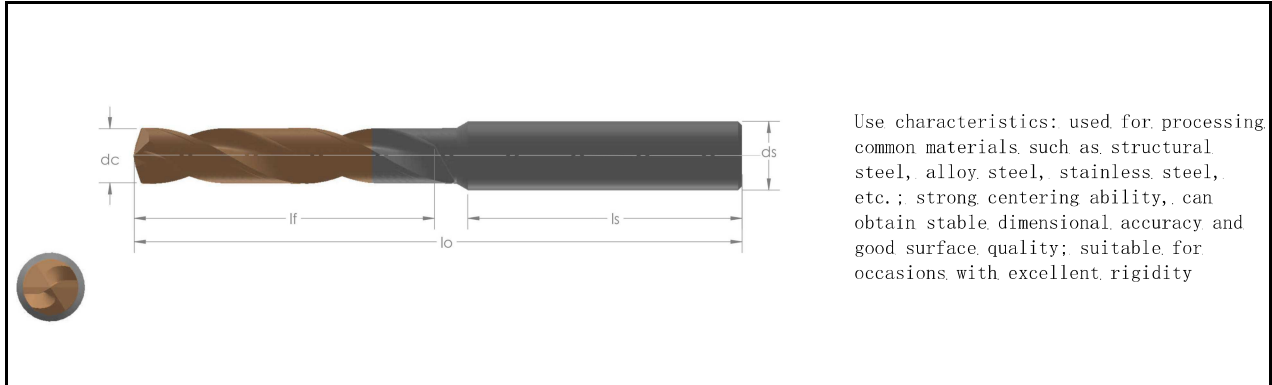

Use characteristics: used for processing common materials such as structural steel, alloy steel, stainless steel, etc.; strong centering ability, can obtain stable dimensional accuracy and good surface quality; suitable for occasions with excellent rigidity

©Solid carbide twist drill: 5xD(DIA); main edge angl

PRODUCT MODEL	DIMENSION					threaded bottom hole	
	dc	lf	ds	ls	lo	cutting tap	extrusion tap
HW-D146-5D	14.6	83	16	48	133	—	—
HW-D147-5D	14.7	83	16	48	133	—	—
HW-D148-5D	14.8	83	16	48	133	5/8-24UNEF	—
HW-D149-5D	14.9	83	16	48	133	—	—
HW-D150-5D	15.0	83	16	48	133	M16×1	M16×2
HW-D151-5D	15.1	83	16	48	133	—	—
HW-D152-5D	15.2	83	16	48	133	—	—
HW-D153-5D	15.3	83	16	48	133	—	—
HW-D154-5D	15.4	83	16	48	133	—	—
HW-D155-5D	15.5	83	16	48	133	M18×2.5	—
HW-D156-5D	15.6	83	16	48	133	—	—
HW-D157-5D	15.7	83	16	48	133	—	—
HW-D158-5D	15.8	83	16	48	133	—	—
HW-D159-5D	15.9	83	16	48	133	—	—
HW-D160-5D	16.0	83	16	48	133	M18×2	—

©Standard drill without internal coolant

HW...3D-C



Solid Carbide Internal Cooling Twist Drill

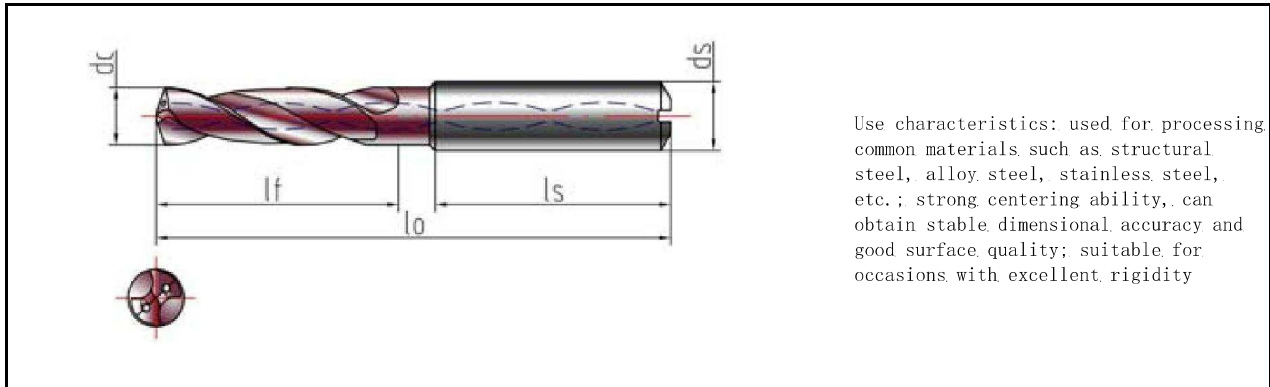

©Solid carbide twist drill: 3xD(DIA); main edge angl

PRODUCT MODEL	DIMENSION					threaded bottom hole	
	dc	lf	ds	ls	lo	cutting tap	extrusion tap
HW-D033-3D-C	3.3	20	4	28	54	M4x0.7	—
HW-D034-3D-C	3.4	20	4	28	54	NO. 8-32UNC	—
HW-D035-3D-C	3.5	20	4	28	54	M4x0.5 NO. 8-36UNC	—
HW-D036-3D-C	3.6	20	4	28	54	—	—
HW-D037-3D-C	3.7	20	4	28	54	—	M4x0.7
HW-D038-3D-C	3.8	24	4	28	58	—	M4x0.5
HW-D039-3D-C	3.9	24	4	28	58	NO. 10-24UNC	—
HW-D040-3D-C	4.0	24	4	28	58	—	—
HW-D041-3D-C	4.1	24	6	36	66	NO. 10-32UNF	—
HW-D042-3D-C	4.2	24	6	36	66	M5x0.8	—
HW-D043-3D-C	4.3	24	6	36	66	—	—
HW-D044-3D-C	4.4	24	6	36	66	—	—
HW-D045-3D-C	4.5	24	6	36	66	M5x0.5 NO. 12-24UNC	—
HW-D046-3D-C	4.6	24	6	36	66	NO. 12-28UNF	M5x0.8
HW-D047-3D-C	4.7	24	6	36	66	NO. 12-32UNEF	—
HW-D048-3D-C	4.8	28	6	36	66	—	—
HW-D049-3D-C	4.9	28	6	36	66	—	—
HW-D050-3D-C	5.0	28	6	36	66	M6x1	—
HW-D051-3D-C	5.1	28	6	36	66	1/4-20UNC	—
HW-D052-3D-C	5.2	28	6	36	66	—	—
HW-D053-3D-C	5.3	28	6	36	66	M6x0.75	—

©Standard drill with internal coolant

HW...3D-C



Solid Carbide Internal Cooling Twist Drill

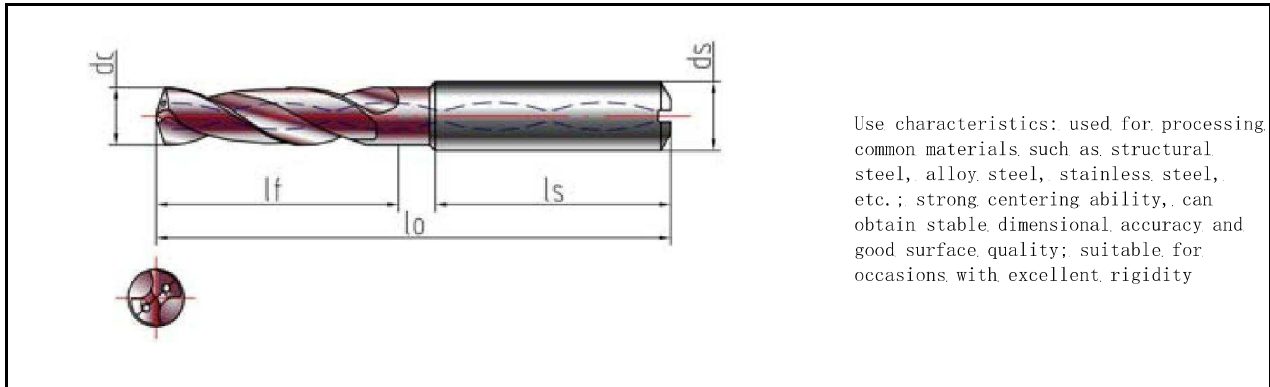

©Solid carbide twist drill: 3xD(DIA); main edge angle

PRODUCT MODEL	DIMENSION					threaded bottom hole	
	dc	lf	ds	ls	lo	cutting tap	extrusion tap
HW-D054-3D-C	5.4	28	6	36	66	—	—
HW-D055-3D-C	5.5	28	6	36	66	1/4-28UNF	M6x1
HW-D056-3D-C	5.6	28	6	36	66	1/4-32UNEF	—
HW-D057-3D-C	5.7	28	6	36	66	—	—
HW-D058-3D-C	5.8	28	6	36	66	—	—
HW-D059-3D-C	5.9	28	6	36	66	—	—
HW-D060-3D-C	6.0	28	6	36	66	—	—
HW-D061-3D-C	6.1	34	8	36	79	—	—
HW-D062-3D-C	6.2	34	8	36	79	—	—
HW-D063-3D-C	6.3	34	8	36	79	—	—
HW-D064-3D-C	6.4	34	8	36	79	—	—
HW-D065-3D-C	6.5	34	8	36	79	—	—
HW-D066-3D-C	6.6	34	8	36	79	5/16-18UNC	—
HW-D067-3D-C	6.7	34	8	36	79	—	—
HW-D068-3D-C	6.8	34	8	36	79	M8x1.25	—
HW-D069-3D-C	6.9	34	8	36	79	5/16-24UNF	—
HW-D070-3D-C	7.0	34	8	36	79	M8x1	—
HW-D071-3D-C	7.1	41	8	36	79	5/16-32UNEF	—
HW-D072-3D-C	7.2	41	8	36	79	—	—
HW-D073-3D-C	7.3	41	8	36	79	M8x0.75	—
HW-D074-3D-C	7.4	41	8	36	79	—	M8x1.25
HW-D075-3D-C	7.5	41	8	36	79	—	—

©Standard drill with internal coolant

HW...3D-C



Solid Carbide Internal Cooling Twist Drill

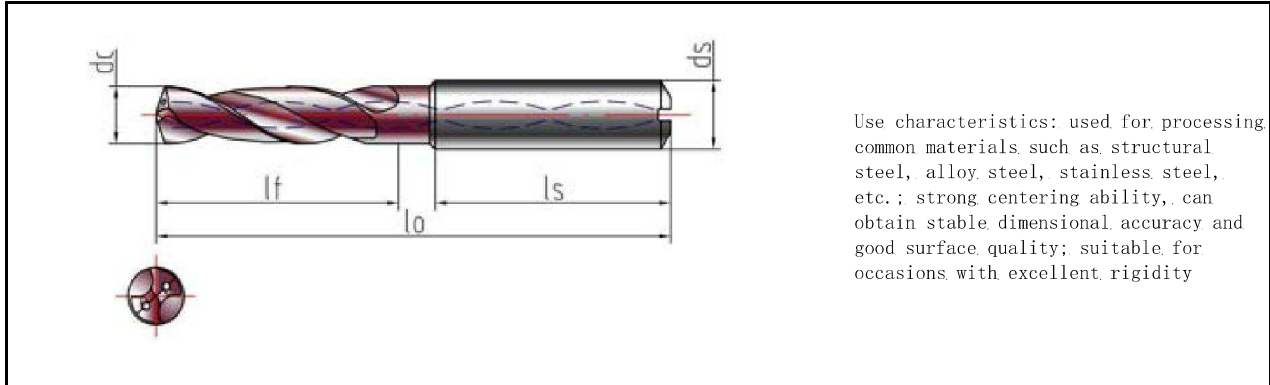

©Solid carbide twist drill: 3xD(DIA); main edge angl

PRODUCT MODEL	DIMENSION					threaded bottom hole	
	dc	lf	ds	ls	lo	cutting tap	extrusion tap
HW-D076-3D-C	7.6	41	8	36	79	—	—
HW-D077-3D-C	7.7	41	8	36	79	—	—
HW-D078-3D-C	7.8	41	8	36	79	—	—
HW-D079-3D-C	7.9	41	8	36	79	—	—
HW-D080-3D-C	8.0	41	8	36	79	3/8-16UNC	—
HW-D081-3D-C	8.1	47	10	40	89	—	—
HW-D082-3D-C	8.2	47	10	40	89	—	—
HW-D083-3D-C	8.3	47	10	40	89	—	—
HW-D084-3D-C	8.4	47	10	40	89	—	—
HW-D085-3D-C	8.5	47	10	40	89	M10x1.5 3/8-24UNF	—
HW-D086-3D-C	8.6	47	10	40	89	—	—
HW-D087-3D-C	8.7	47	10	40	89	3/8-32UNEF	—
HW-D088-3D-C	8.8	47	10	40	89	M10x1.25	—
HW-D089-3D-C	8.9	47	10	40	89	—	—
HW-D090-3D-C	9.0	47	10	40	89	M10x1	—
HW-D091-3D-C	9.1	47	10	40	89	—	—
HW-D092-3D-C	9.2	47	10	40	89	—	—
HW-D093-3D-C	9.3	47	10	40	89	M10x0.75	M10x1.5
HW-D094-3D-C	9.4	47	10	40	89	7/16-14UNC	—
HW-D095-3D-C	9.5	47	10	40	89	—	—
HW-D097-3D-C	9.7	47	10	40	89	—	—
HW-D098-3D-C	9.8	47	10	40	89	—	—

©Standard drill with internal coolant

HW...3D-C



Solid Carbide Internal Cooling Twist Drill

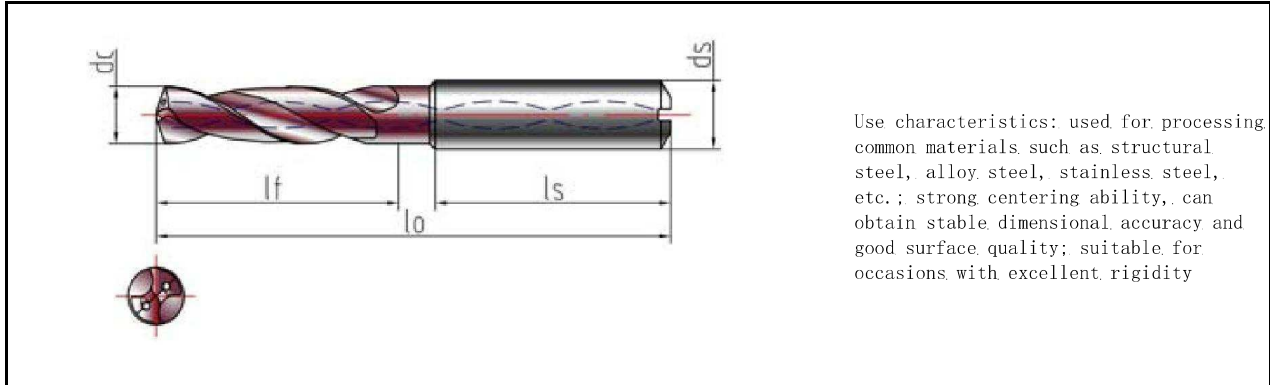

©Solid carbide twist drill: 3xD(DIA); main edge angl

PRODUCT MODEL	DIMENSION					threaded bottom hole	
	dc	lf	ds	ls	lo	cutting tap	extrusion tap
HW-D099-3D-C	9.9	47	10	40	89	7/16-20UNF	—
HW-D100-3D-C	10.0	47	10	40	89	—	—
HW-D101-3D-C	10.1	55	12	45	102	—	—
HW-D102-3D-C	10.2	55	12	45	102	7/16-28UNEF	—
HW-D103-3D-C	10.3	55	12	45	102	M12x1.75	—
HW-D104-3D-C	10.4	55	12	45	102	—	—
HW-D105-3D-C	10.5	55	12	45	102	—	—
HW-D106-3D-C	10.6	55	12	45	102	—	—
HW-D107-3D-C	10.7	55	12	45	102	—	—
HW-D108-3D-C	10.8	55	12	45	102	—	—
HW-D109-3D-C	10.9	55	12	45	102	1/2-13UNC	—
HW-D110-3D-C	11.0	55	12	45	102	M12x1	—
HW-D111-3D-C	11.1	55	12	45	102	—	—
HW-D112-3D-C	11.2	55	12	45	102	—	M12x1.75
HW-D113-3D-C	11.3	55	12	45	102	—	—
HW-D114-3D-C	11.4	55	12	45	102	—	—
HW-D115-3D-C	11.5	55	12	45	102	1/2-20UNF	—
HW-D116-3D-C	11.6	55	12	45	102	—	—
HW-D117-3D-C	11.7	55	12	45	102	—	—
HW-D118-3D-C	11.8	55	12	45	102	1/2-28UNEF	—
HW-D119-3D-C	11.9	55	12	45	102	—	—
HW-D120-3D-C	12.0	55	12	45	102	M14x2	—

©Standard drill with internal coolant

HW...3D-C



Solid Carbide Internal Cooling Twist Drill

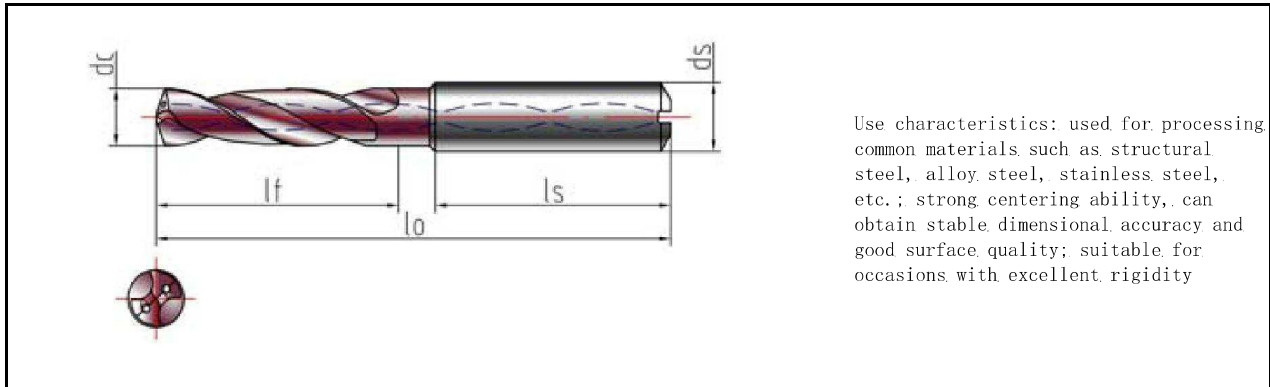

Use characteristics: used for processing common materials such as structural steel, alloy steel, stainless steel, etc.; strong centering ability, can obtain stable dimensional accuracy and good surface quality; suitable for occasions with excellent rigidity

©Solid carbide twist drill: 3xD(DIA); main edge angle

PRODUCT MODEL	DIMENSION					threaded bottom hole	
	dc	lf	ds	ls	lo	cutting tap	extrusion tap
HW-D121-3D-C	12.1	60	14	45	107	—	—
HW-D122-3D-C	12.2	60	14	45	107	9/16-12UNC	—
HW-D123-3D-C	12.3	60	14	45	107	—	—
HW-D124-3D-C	12.4	60	14	45	107	—	—
HW-D125-3D-C	12.5	60	14	45	107	M14x1.5	—
HW-D126-3D-C	12.6	60	14	45	107	—	—
HW-D127-3D-C	12.7	60	14	45	107	—	—
HW-D128-3D-C	12.8	60	14	45	107	—	—
HW-D129-3D-C	12.9	60	14	45	107	9/16-18UNF	—
HW-D130-3D-C	13.0	60	14	45	107	M14x1	M14x2
HW-D131-3D-C	13.1	60	14	45	107	—	—
HW-D132-3D-C	13.2	60	14	45	107	9/16-24UNEF	—
HW-D133-3D-C	13.3	60	14	45	107	—	—
HW-D134-3D-C	13.4	60	14	45	107	—	—
HW-D135-3D-C	13.5	60	14	45	107	—	—
HW-D136-3D-C	13.6	60	14	45	107	5/8-11UNC	—
HW-D137-3D-C	13.7	60	14	45	107	—	—
HW-D138-3D-C	13.8	60	14	45	107	—	—
HW-D139-3D-C	13.9	60	14	45	107	—	—
HW-D140-3D-C	14.0	60	14	45	107	M16x2	—
HW-D141-3D-C	14.1	65	16	48	115	—	—
HW-D142-3D-C	14.2	65	16	48	115	—	—
HW-D143-3D-C	14.3	65	16	48	115	—	—

©Standard drill with internal coolant

HW...3D-C



Solid Carbide Internal Cooling Twist Drill

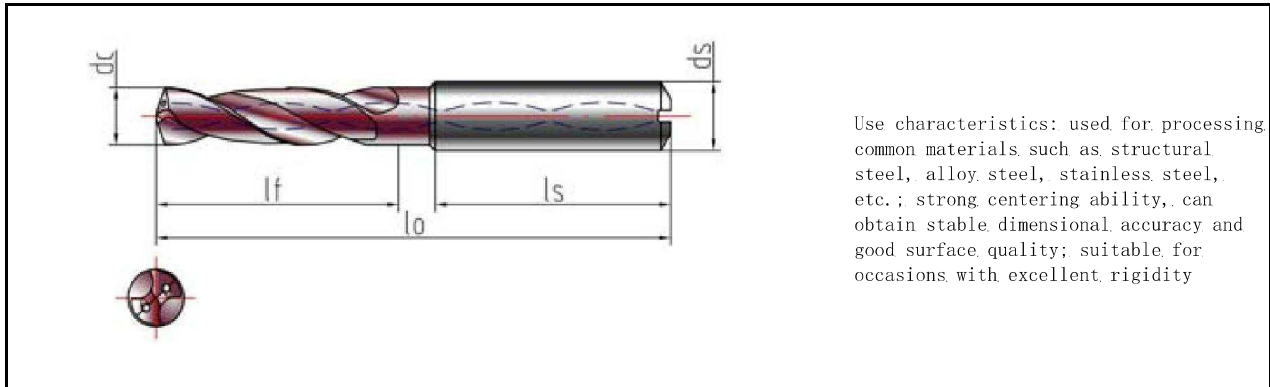

Use characteristics: used for processing common materials such as structural steel, alloy steel, stainless steel, etc.; strong centering ability, can obtain stable dimensional accuracy and good surface quality; suitable for occasions with excellent rigidity

©Solid carbide twist drill: 3xD(DIA); main edge angl

PRODUCT MODEL	DIMENSION					threaded bottom hole	
	dc	lf	ds	ls	lo	cutting tap	extrusion tap
HW-D144-3D-C	14.4	65	16	48	115	—	—
HW-D145-3D-C	14.5	65	16	48	115	M16x1.5	—
HW-D145-3D-C	14.5	65	16	48	115	5/8-18UNF	—
HW-D146-3D-C	14.6	65	16	48	115	—	—
HW-D147-3D-C	14.7	65	16	48	115	—	—
HW-D148-3D-C	14.8	65	16	48	115	5/8-24UNEF	—
HW-D149-3D-C	14.9	65	16	48	115	—	—
HW-D150-3D-C	15.0	65	16	48	115	M16x1	M16x2
HW-D151-3D-C	15.1	65	16	48	115	—	—
HW-D152-3D-C	15.2	65	16	48	115	—	—
HW-D153-3D-C	15.3	65	16	48	115	—	—
HW-D154-3D-C	15.4	65	16	48	115	—	—
HW-D155-3D-C	15.5	65	16	48	115	M18x2.5	—
HW-D156-3D-C	15.6	65	16	48	115	—	—
HW-D157-3D-C	15.7	65	16	48	115	—	—
HW-D158-3D-C	15.8	65	16	48	115	—	—
HW-D159-3D-C	15.9	65	16	48	115	—	—
HW-D160-3D-C	16.0	65	16	48	115	M18x2	—

©Standard drill with internal coolant

HW...5D-C



Solid Carbide Internal Cooling Twist Drill

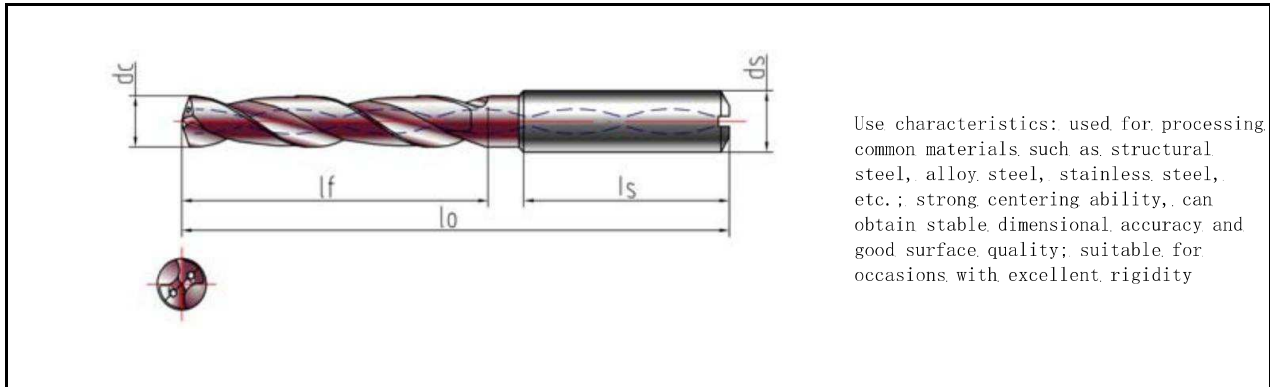

©Solid carbide twist drill: 5xD(DIA); main edge angl

PRODUCT MODEL	DIMENSION					threaded bottom hole	
	dc	lf	ds	ls	lo	cutting tap	extrusion tap
HW-D033-5D-C	3.3	28	4	28	58	M4×0.7	—
HW-D034-5D-C	3.4	28	4	28	58	No. 8-32UNC	—
HW-D035-5D-C	3.5	28	4	28	58	M4×0.5 No. 8-36UNF	—
HW-D036-5D-C	3.6	28	4	28	58	—	—
HW-D037-5D-C	3.7	28	4	28	58	—	M4×0.7
HW-D038-5D-C	3.8	36	4	28	66	—	M4×0.5
HW-D039-5D-C	3.9	36	4	28	66	No. 10-24UNC	—
HW-D040-5D-C	4.0	36	4	28	66	—	—
HW-D041-5D-C	4.1	36	6	36	74	No. 10-32UNF	—
HW-D042-5D-C	4.2	36	6	36	74	M5×0.8	—
HW-D043-5D-C	4.3	36	6	36	74	—	—
HW-D044-5D-C	4.4	36	6	36	74	—	—
HW-D045-5D-C	4.5	36	6	36	74	M5×0.5 No. 12-24UNC	—
HW-D046-5D-C	4.6	36	6	36	74	No. 12-28UNF	M5×0.8
HW-D047-5D-C	4.7	36	6	36	74	No. 12-32UNEF	—
HW-D048-5D-C	4.8	44	6	36	82	—	—
HW-D049-5D-C	4.9	44	6	36	82	—	—
HW-D050-5D-C	5.0	44	6	36	82	M6×1	—
HW-D051-5D-C	5.1	44	6	36	82	1/4-20UNC	—
HW-D052-5D-C	5.2	44	6	36	82	—	—
HW-D053-5D-C	5.3	44	6	36	82	M6×0.75	—

©Standard drill with internal coolant

HW...5D-C



Solid Carbide Internal Cooling Twist Drill

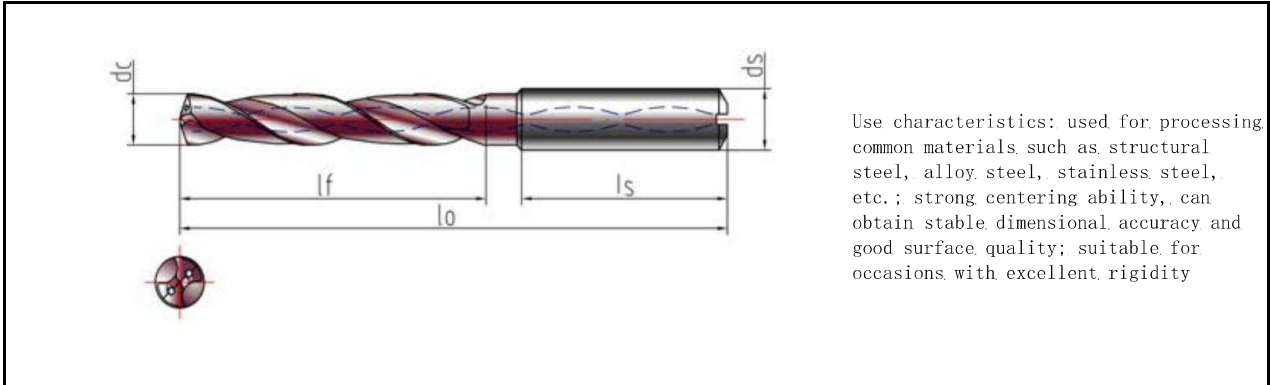

©Solid carbide twist drill: 5xD(DIA); main edge angl

PRODUCT MODEL	DIMENSION					threaded bottom hole	
	dc	lf	ds	ls	lo	cutting tap	extrusion tap
HW-D054-5D-C	5.4	44	6	36	82	—	—
HW-D055-5D-C	5.5	44	6	36	82	1/4-28UNF	M6×1
HW-D056-5D-C	5.6	44	6	36	82	1/4-32UNEF	—
HW-D057-5D-C	5.7	44	6	36	82	—	—
HW-D058-5D-C	5.8	44	6	36	82	—	—
HW-D059-5D-C	5.9	44	6	36	82	—	—
HW-D060-5D-C	6.0	44	6	36	82	—	—
HW-D061-5D-C	6.1	53	8	36	91	—	—
HW-D062-5D-C	6.2	53	8	36	91	—	—
HW-D063-5D-C	6.3	53	8	36	91	—	—
HW-D064-5D-C	6.4	53	8	36	91	—	—
HW-D065-5D-C	6.5	53	8	36	91	—	—
HW-D066-5D-C	6.6	53	8	36	91	5/16-18UNC	—
HW-D067-5D-C	6.7	53	8	36	91	—	—
HW-D068-5D-C	6.8	53	8	36	91	M8×1.25	—
HW-D069-5D-C	6.9	53	8	36	91	5/16-24UNEF	—
HW-D070-5D-C	7.0	53	8	36	91	M8×1	—
HW-D071-5D-C	7.1	53	8	36	91	5/16-32UNEF	—
HW-D072-5D-C	7.2	53	8	36	91	—	—
HW-D073-5D-C	7.3	53	8	36	91	M8×0.75	—
HW-D074-5D-C	7.4	53	8	36	91	—	M8×1.25
HW-D075-5D-C	7.5	53	8	36	91	—	—
HW-D076-5D-C	7.6	53	8	36	91	—	—

©Standard drill with internal coolant

HW...5D-C



Solid Carbide Internal Cooling Twist Drill

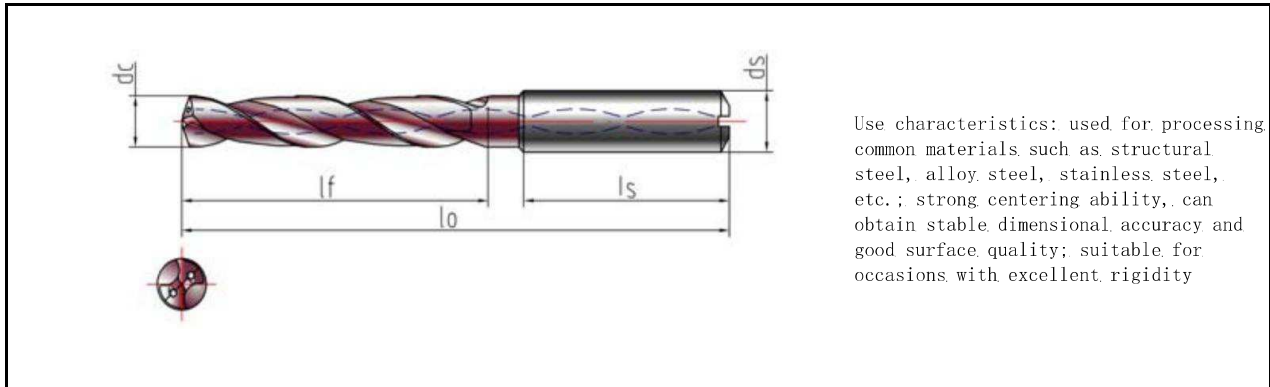

©Solid carbide twist drill: 5xD(DIA); main edge angle

PRODUCT MODEL	DIMENSION					threaded bottom hole	
	dc	lf	ds	ls	lo	cutting tap	extrusion tap
HW-D077-5D-C	7.7	53	8	36	91	—	—
HW-D078-5D-C	7.8	53	8	36	91	—	—
HW-D079-5D-C	7.9	53	8	36	91	—	—
HW-D080-5D-C	8.0	53	8	36	91	3/8-16UNC	—
HW-D081-5D-C	8.1	61	10	40	103	—	—
HW-D082-5D-C	8.2	61	10	40	103	—	—
HW-D083-5D-C	8.3	61	10	40	103	—	—
HW-D084-5D-C	8.4	61	10	40	103	—	—
HW-D085-5D-C	8.5	61	10	40	103	M10×1.5 3/8-24UNF	—
HW-D086-5D-C	8.6	61	10	40	103	—	—
HW-D087-5D-C	8.7	61	10	40	103	3/8-32UNEF	—
HW-D088-5D-C	8.8	61	10	40	103	M10×1.25	—
HW-D089-5D-C	8.9	61	10	40	103	—	—
HW-D090-5D-C	9.0	61	10	40	103	M10×1	—
HW-D091-5D-C	9.1	61	10	40	103	—	—
HW-D092-5D-C	9.2	61	10	40	103	—	—
HW-D093-5D-C	9.3	61	10	40	103	M10×0.75	M10×1.5
HW-D094-5D-C	9.4	61	10	40	103	7/16-14UNC	—
HW-D095-5D-C	9.5	61	10	40	103	—	—
HW-D096-5D-C	9.6	61	10	40	103	—	—
HW-D097-5D-C	9.7	61	10	40	103	—	—
HW-D098-5D-C	9.8	61	10	40	103	—	—
HW-D099-5D-C	9.9	61	10	40	103	7/16-20UNF	—

©Standard drill with internal coolant

HW...5D-C



Solid Carbide Internal Cooling Twist Drill

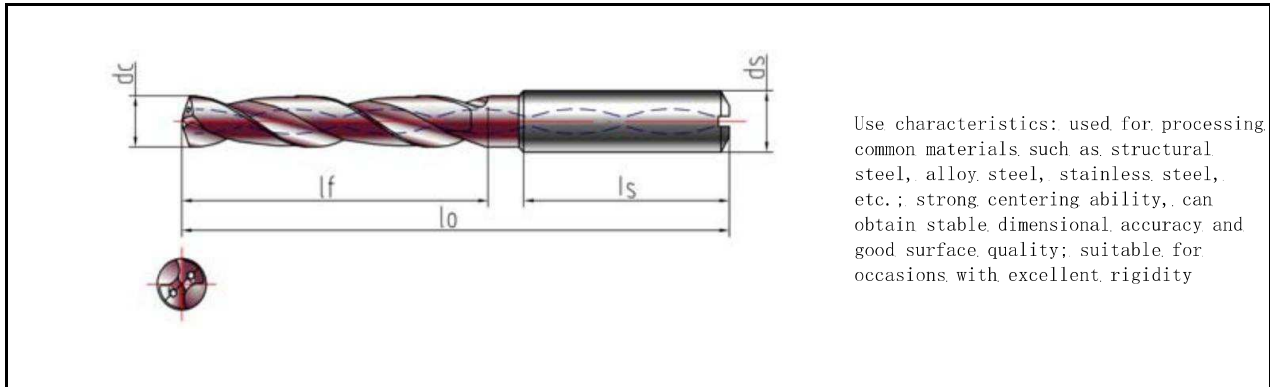

©Solid carbide twist drill: 5xD(DIA); main edge angl

PRODUCT MODEL	DIMENSION					threaded bottom hole	
	dc	lf	ds	ls	lo	cutting tap	extrusion tap
HW-D100-5D-C	10.0	61	10	40	103	—	—
HW-D101-5D-C	10.1	71	12	45	118	—	—
HW-D102-5D-C	10.2	71	12	45	118	7/16-28UNEF	—
HW-D103-5D-C	10.3	71	12	45	118	M12×1.75	—
HW-D104-5D-C	10.4	71	12	45	118	—	—
HW-D105-5D-C	10.5	71	12	45	118	—	—
HW-D106-5D-C	10.6	71	12	45	118	—	—
HW-D107-5D-C	10.7	71	12	45	118	—	—
HW-D108-5D-C	10.8	71	12	45	118	—	—
HW-D109-5D-C	10.9	71	12	45	118	1/2-13UNC	—
HW-D110-5D-C	11.0	71	12	45	118	M12×1	—
HW-D111-5D-C	11.1	71	12	45	118	—	—
HW-D112-5D-C	11.2	71	12	45	118	—	M12×1.75
HW-D113-5D-C	11.3	71	12	45	118	—	—
HW-D114-5D-C	11.4	71	12	45	118	—	—
HW-D115-5D-C	11.5	71	12	45	118	1/2-20UNF	—
HW-D116-5D-C	11.6	71	12	45	118	—	—
HW-D117-5D-C	11.7	71	12	45	118	—	—
HW-D118-5D-C	11.8	71	12	45	118	1/2-28UNEF	—
HW-D119-5D-C	11.9	71	12	45	118	—	—
HW-D120-5D-C	12.0	71	12	45	118	M14×2	—
HW-D121-5D-C	12.1	77	14	45	124	—	—
HW-D122-5D-C	12.2	77	14	45	124	9/16-12UNC	—

©Standard drill with internal coolant

HW...5D-C



Solid Carbide Internal Cooling Twist Drill

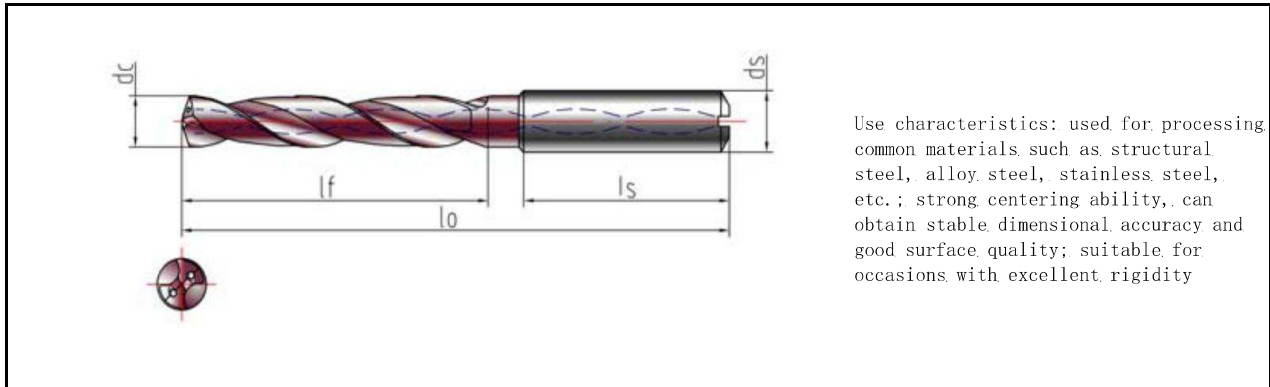

©Solid carbide twist drill: 5xD(DIA); main edge angl

PRODUCT MODEL	DIMENSION					threaded bottom hole	
	dc	lf	ds	ls	lo	cutting tap	extrusion tap
HW-D123-5D-C	12.3	77	14	45	124	—	—
HW-D124-5D-C	12.4	77	14	45	124	—	—
HW-D125-5D-C	12.5	77	14	45	124	M14×1.5	—
HW-D126-5D-C	12.6	77	14	45	124	—	—
HW-D127-5D-C	12.7	77	14	45	124	—	—
HW-D128-5D-C	12.8	77	14	45	124	—	—
HW-D129-5D-C	12.9	77	14	45	124	9/16-18UNF	—
HW-D130-5D-C	13.0	77	14	45	124	M14×1	M14×2
HW-D131-5D-C	13.1	77	14	45	124	—	—
HW-D132-5D-C	13.2	77	14	45	124	9/16-24UNEF	—
HW-D133-5D-C	13.3	77	14	45	124	—	—
HW-D134-5D-C	13.4	77	14	45	124	—	—
HW-D135-5D-C	13.5	77	14	45	124	—	—
HW-D136-5D-C	13.6	77	14	45	124	5/8-11UNC	—
HW-D137-5D-C	13.7	77	14	45	124	—	—
HW-D138-5D-C	13.8	77	14	45	124	—	—
HW-D139-5D-C	13.9	77	14	45	124	—	—
HW-D140-5D-C	14.0	77	14	45	124	M16×2	—
HW-D141-5D-C	14.1	83	16	48	133	—	—
HW-D142-5D-C	14.2	83	16	48	133	—	—
HW-D143-5D-C	14.3	83	16	48	133	—	—
HW-D144-5D-C	14.4	83	16	48	133	—	—
HW-D145-5D-C	14.5	83	16	48	133	M16×1.5	—
HW-D145-5D-C	14.5	83	16	48	133	5/8-18UNF	—

©Standard drill with internal coolant

HW...5D-C



Solid Carbide Internal Cooling Twist Drill

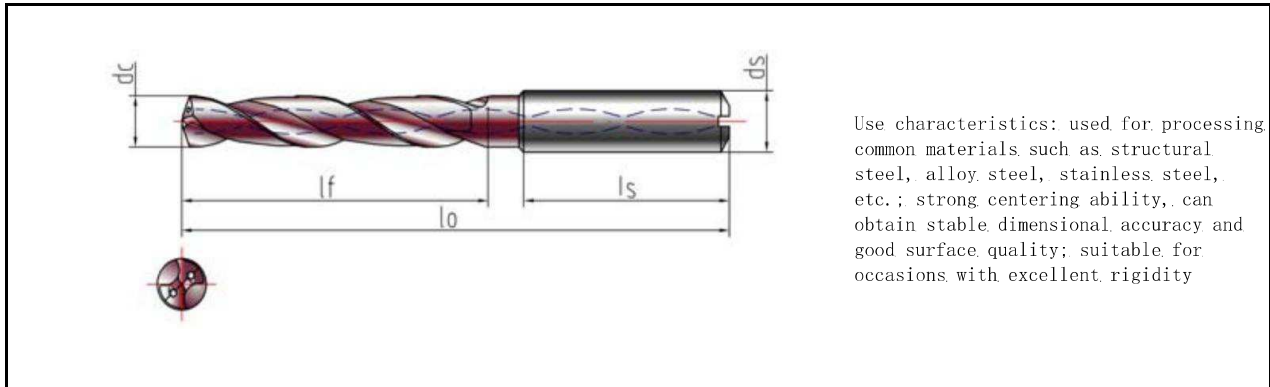

©Solid carbide twist drill: 5xD(DIA); main edge angl

PRODUCT MODEL	DIMENSION					threaded bottom hole	
	dc	lf	ds	ls	lo	cutting tap	extrusion tap
HW-D146-5D-C	14.6	83	16	48	133	—	—
HW-D147-5D-C	14.7	83	16	48	133	—	—
HW-D148-5D-C	14.8	83	16	48	133	5/8-24UNEF	—
HW-D149-5D-C	14.9	83	16	48	133	—	—
HW-D150-5D-C	15.0	83	16	48	133	M16×1	M16×2
HW-D151-5D-C	15.1	83	16	48	133	—	—
HW-D152-5D-C	15.2	83	16	48	133	—	—
HW-D153-5D-C	15.3	83	16	48	133	—	—
HW-D154-5D-C	15.4	83	16	48	133	—	—
HW-D155-5D-C	15.5	83	16	48	133	M18×2.5	—
HW-D156-5D-C	15.6	83	16	48	133	—	—
HW-D157-5D-C	15.7	83	16	48	133	—	—
HW-D158-5D-C	15.8	83	16	48	133	—	—
HW-D159-5D-C	15.9	83	16	48	133	—	—
HW-D160-5D-C	16.0	83	16	48	133	M18×2	—



©Standard drill with internal coolant



HEAD CHANGEABLE DRILL

HEAD CHANGABLE DRILL INSERTS

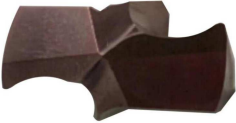
Groove TYPE introduction

Groove code	SHAPE	INTRODUCTION
RC		<p>RC TYPE: Low cutting force, good centering performance. Reinforced cutting edge, high chipping resistance, excellent chip control ability, effectively prolong tool life.</p>
SE		<p>SE TYPE: The cutter head has a self-centering and strong SE-type chisel edge, which avoids hardening of the core and increases the feed rate. The rounded sickle-shaped cutting edge provides excellent chip control and long tool life, even in long-chipping materials. Suitable for processing steel, stainless steel and cast iron.</p>

GRADE INTRODUCTION

GRADE CODE	INTRODUCTION
HW0620	<p>It is made of a fine-grained cemented carbide with a PVD composite coating of TiAlN matrix. It has high wear resistance and can use very high cutting speed parameters under stable conditions</p>
HW8420	<p>Cutting edge particularly suitable for drilling in alloy and high alloy steels</p>
HW0622	<p>Cutting edge as an alternative for machining cast iron materials</p>

HWD-RC



HEAD CHANGABLE DRILL INSERTS

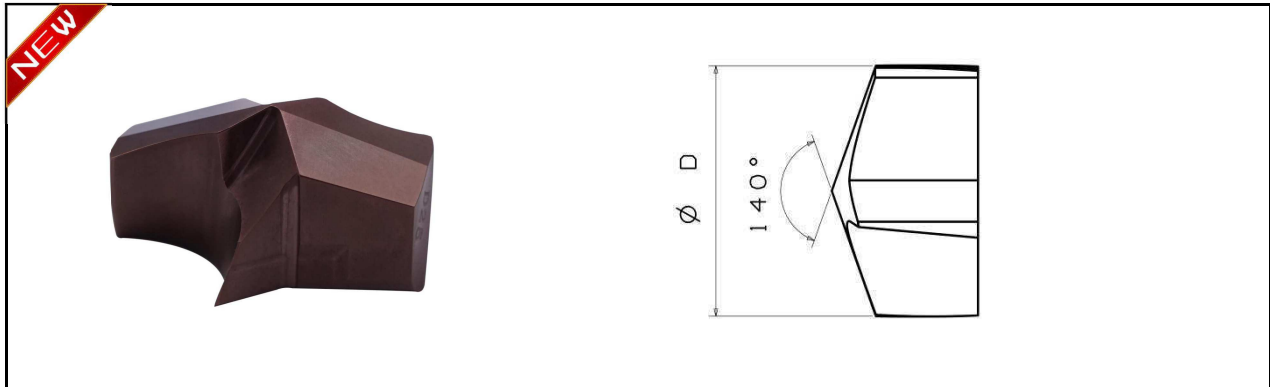

PRODUCT MODEL	DIMENSION			toleranceK7 (METRIC)
	D		HOLDER SIZE	
	mm	In		
HWD1250RC	12.50	0.4921	C	+0.001 /+0.019
HWD1300RC	13.00	0.5118	C	
HWD1350RC	13.50	0.531	C	
HWD1351RC	13.51	0.5319	B	
HWD1400RC	14.00	0.5512	B	
HWD1450RC	14.50	0.5709	B	
HWD1451RC	14.51	0.5713	A	
HWD1500RC	15.00	0.5906	A	
HWD1550RC	15.50	0.6102	A	
HWD1600RC	16.00	0.6299	1	
HWD1650RC	16.50	0.6496	1	
HWD1700RC	17.00	0.6693	1	
HWD1750RC	17.50	0.689	1	
HWD1800RC	18.00	0.7087	1	
HWD1801RC	18.01	0.7087	2	
HWD1850RC	18.50	0.7283	2	
HWD1900RC	19.00	0.748	2	
HWD1950RC	19.50	0.7677	2	
HWD2000RC	20.00	0.7874	3	
HWD2050RC	20.50	0.8071	3	
HWD2100RC	21.00	0.8268	3	
HWD2150RC	21.50	0.8460	3	
HWD2200RC	22.00	0.8661	3	
HWD2201RC	22.01	0.8665	4	

HWD-RC



HEAD CHANGABLE DRILL INSERTS

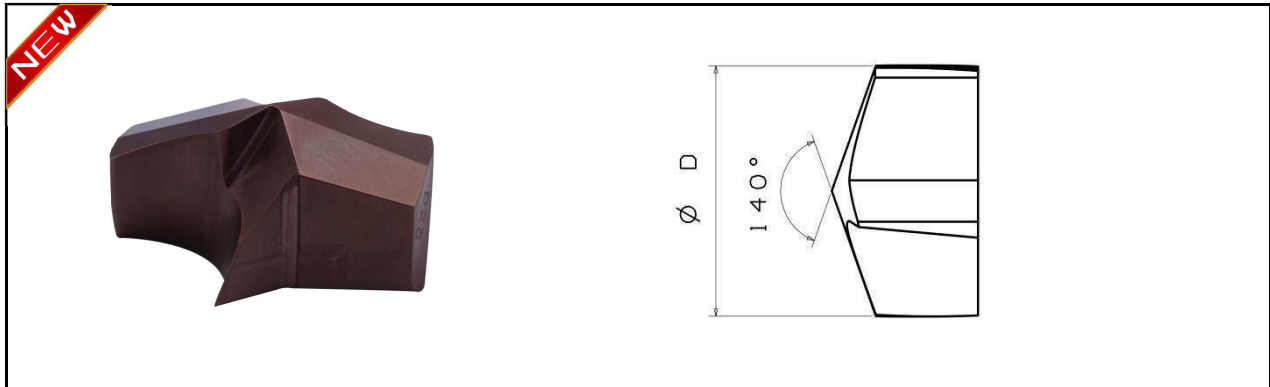

PRODUCT MODEL	DIMENSION			toleranceK7 (METRIC)
	D		HOLDER SIZE	
	mm	In		
HWD2250RC	22.50	0.8858	4	+0.002 /+0.023
HWD2300RC	23.00	0.9055	4	
HWD2350RC	23.50	0.9252	4	
HWD2400RC	24.00	0.9449	4	
HWD2401RC	24.01	0.9453	5	
HWD2450RC	24.50	0.9646	5	
HWD2500RC	25.00	0.9843	5	
HWD2550RC	25.50	1.0039	5	
HWD2600RC	26.00	1.0236	5	
HWD2601RC	26.01	1.0240	6	
HWD2650RC	26.50	1.0433	6	
HWD2700RC	27.00	1.0630	6	
HWD2750RC	27.50	1.0827	6	
HWD2800RC	28.00	1.1024	6	
HWD2801RC	28.016	1.1030	7	
HWD2850RC	28.50	1.1220	7	
HWD2900RC	29.00	1.1417	7	
HWD2950RC	29.50	1.1614	7	
HWD3000RC	30.00	1.1811	7	+0.002 /+0.027
HWD3001RC	30.01	1.1815	8	
HWD3050RC	30.50	1.2008	8	
HWD3100RC	31.00	1.2205	8	
HWD3150RC	31.50	1.2402	8	
HWD3200RC	32.00	1.2598	8	

HWD-SE



HEAD CHANGABLE DRILL INSERTS

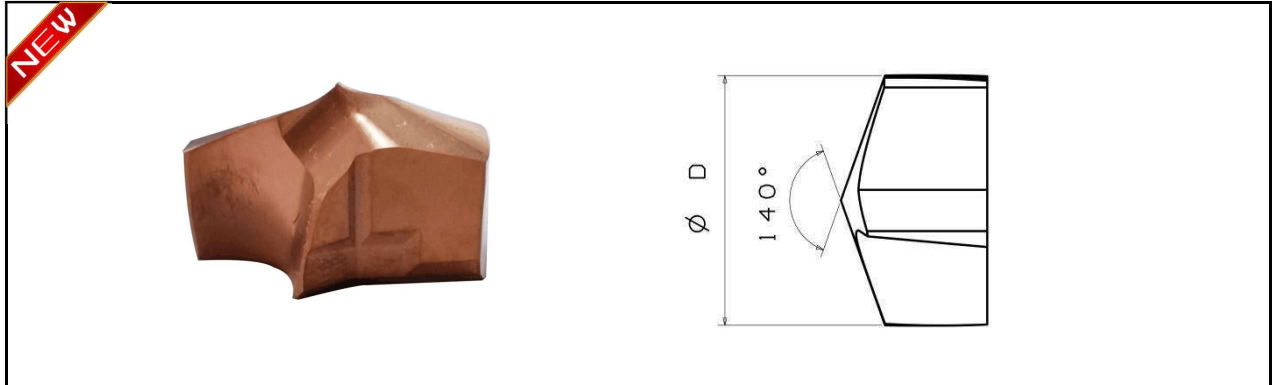

PRODUCT MODEL	DIMENSION			toleranceK7 (METRIC)
	D		HOLDER SIZE	
	mm	In		
HWD1250SE	12.50	0.4921	C	+0.001 /+0.019
HWD1300SE	13.00	0.5118	C	
HWD1350SE	13.50	0.531	C	
HWD1351SE	13.51	0.5319	B	
HWD1400SE	14.00	0.5512	B	
HWD1450SE	14.50	0.5709	B	
HWD1451SE	14.51	0.5713	A	
HWD1500SE	15.00	0.5906	A	
HWD1550SE	15.50	0.6102	A	
HWD1600SE	16.00	0.6299	1	
HWD1650SE	16.50	0.6496	1	
HWD1700SE	17.00	0.6693	1	
HWD1750SE	17.50	0.689	1	
HWD1800SE	18.00	0.7087	1	
HWD1801SE	18.01	0.7087	2	
HWD1850SE	18.50	0.7283	2	
HWD1900SE	19.00	0.748	2	
HWD1950SE	19.50	0.7677	2	
HWD2000SE	20.00	0.7874	3	
HWD2050SE	20.50	0.8071	3	
HWD2100SE	21.00	0.8268	3	
HWD2150SE	21.50	0.8460	3	
HWD2200SE	22.00	0.8661	3	
HWD2201SE	22.01	0.8665	4	

HW-SE



HEAD CHANGABLE DRILL INSERTS

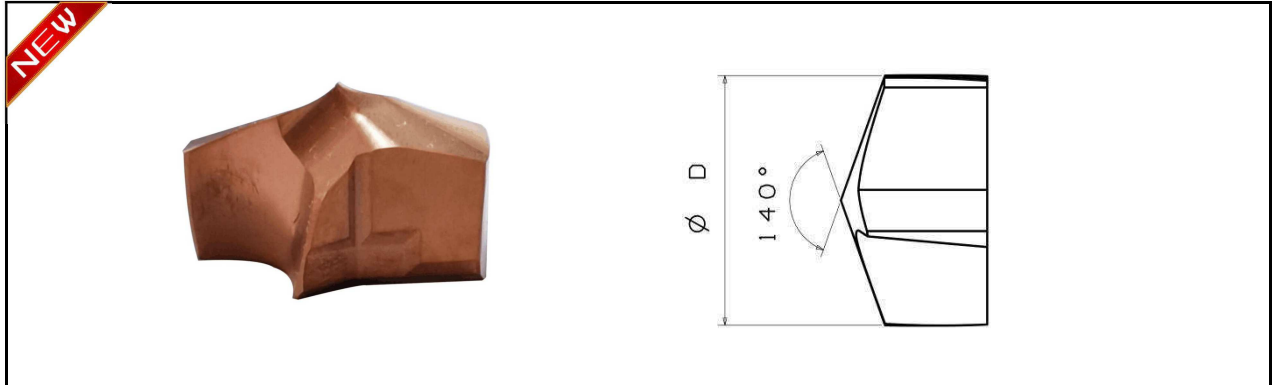

PRODUCT MODEL	DIMENSION			toleranceK7 (METRIC)
	D		HOLDER SIZE	
	mm	In		
HWD2250SE	22.50	0.8858	4	+0.002 /+0.023
HWD2300SE	23.00	0.9055	4	
HWD2350SE	23.50	0.9252	4	
HWD2400SE	24.00	0.9449	4	
HWD2401SE	24.01	0.9453	5	
HWD2450SE	24.50	0.9646	5	
HWD2500SE	25.00	0.9843	5	
HWD2550SE	25.50	1.0039	5	
HWD2600SE	26.00	1.0236	5	
HWD2601SE	26.01	1.0240	6	
HWD2650SE	26.50	1.0433	6	
HWD2700SE	27.00	1.0630	6	
HWD2750SE	27.50	1.0827	6	
HWD2800SE	28.00	1.1024	6	
HWD2801SE	28.016	1.1030	7	
HWD2850SE	28.50	1.1220	7	
HWD2900SE	29.00	1.1417	7	
HWD2950SE	29.50	1.1614	7	
HWD3000SE	30.00	1.1811	7	
HWD3001SE	30.01	1.1815	8	
HWD3050SE	30.50	1.2008	8	
HWD3100SE	31.00	1.2205	8	
HWD3150SE	31.50	1.2402	8	
HWD3200SE	32.00	1.2598	8	

HWD-R1



HEAD CHANGABLE DRILL HOLDER

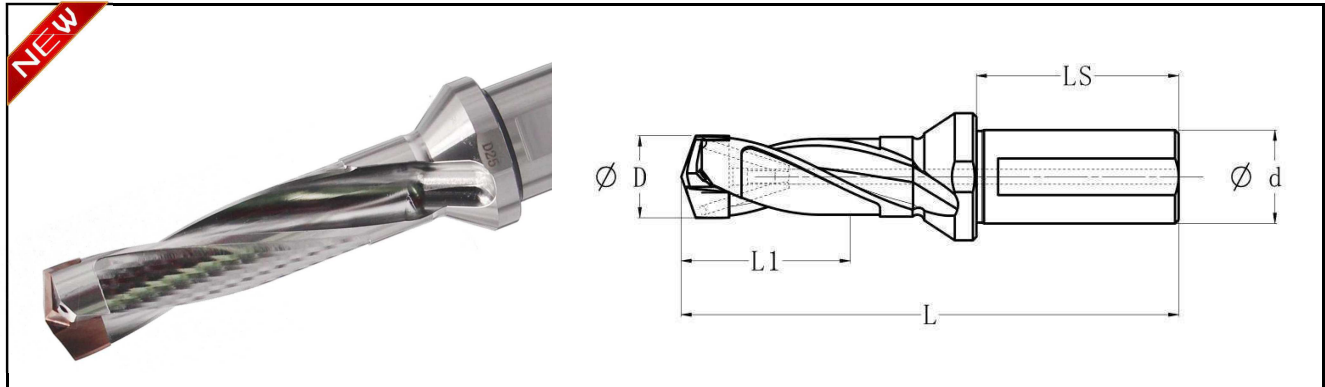

• HWD • 1 x D • METRIC

PRODUCT MODEL	DIMENSION								
	D		Dmax		L1	LS	d	L	HOLDER SIZE
	mm	in	mm	in					
1 x D									
HWD125R1WD16M	12.500	0.4921	13.500	0.5314	14	48	16	78	c
HWD136R1WD16M	13.510	0.5319	14.500	0.5708	15	48	16	81	B
HWD146R1WD20M	14.510	0.5713	15.874	0.6249	16	50	20	85	A
HWD160R1WD20M	16.000	0.6299	18.000	0.7086	18	50	20	88	1
HWD181R1WD25M	18.010	0.7091	19.999	0.7873	20	56	25	99	2
HWD200R1WD25M	20.000	0.7874	22.000	0.8661	22	56	25	102	3
HWD221R1WD25M	22.010	0.8665	24.000	0.9448	24	56	25	107	4
HWD241R1WD32M	24.010	0.9453	26.000	1.0236	26	60	32	115	5
HWD261R1WD32M	26.010	1.0240	28.000	1.1023	28	60	32	119	6
HWD281R1WD32M	28.016	1.1030	30.000	1.1811	30	60	32	123	7
HWD301R1WD32M	30.010	1.1815	32.000	1.2598	32	60	32	127	8

- This tool holder has internal coolant
- holder should use correct inerts
- Inserts to be ordered separately
- For information on adapting screw wrenches, see page C61; for usage, see page C62

HWD-R3/R5



HEAD CHANGABLE DRILL HOLDER

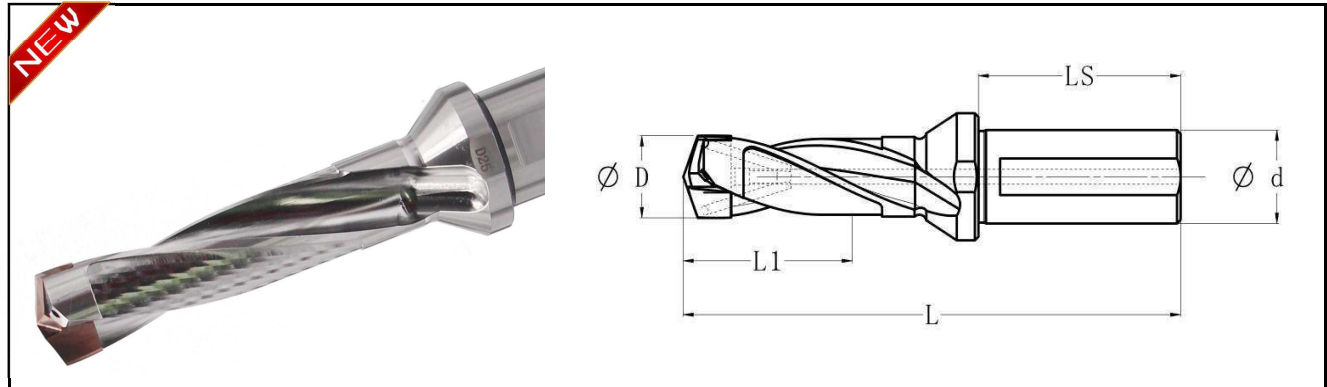

• HWD • 3 x D / 5 x D • METRIC

PRODUCT MODEL	PRODUCT MODEL	DIMENSION								
		D		Dmax		L1		LS	d	SIZE
3 x D	5 x D	mm	in	mm	in	3XD	5XD			
HWD125R3WD16M	HWD125R5WD16M	12.500	0.4921	13.000	0.5118	42	70	48	16	C
HWD130R3WD16M	HWD130R5WD16M	13.000	0.5118	13.500	0.5314	42	70	48	16	C
HWD135R3WD16M	HWD135R5WD16M	13.500	0.5315	13.500	0.5314	42	70	48	16	C
HWD136R3WD16M	HWD136R5WD16M	13.510	0.5319	14.000	0.5512	42	70	48	16	B
HWD140R3WD16M	HWD140R5WD16M	14.000	0.5512	14.500	0.5708	42	70	48	16	B
HWD145R3WD20M	HWD145R5WD20M	14.500	0.5709	14.500	0.5708	48	80	50	20	B
HWD146R3WD20M	HWD146R5WD20M	14.510	0.5713	15.000	0.5906	48	80	50	20	A
HWD150R3WD20M	HWD150R5WD20M	15.000	0.5906	15.500	0.6102	48	80	50	20	A
HWD155R3WD20M	HWD155R5WD20M	15.500	0.6102	15.874	0.6249	48	80	50	20	A
HWD160R3WD20M	HWD160R5WD20M	16.000	0.6299	16.500	0.6496	48	80	50	20	1
HWD165R3WD20M	HWD165R5WD20M	16.500	0.6496	17.000	0.6693	54	90	50	20	1
HWD170R3WD20M	HWD170R5WD20M	17.000	0.6693	17.500	0.6890	54	90	50	20	1
HWD175R3WD20M	HWD175R5WD20M	17.500	0.6890	18.000	0.7086	54	90	50	20	1
HWD180R3WD20M	HWD180R5WD20M	18.000	0.7087	18.000	0.7086	54	90	50	20	1
—	HWD181R5WD25M	18.010	0.7091	18.500	0.7283	—	100	56	25	2
HWD185R3WD25M	HWD185R5WD25M	18.500	0.7283	19.000	0.7480	60	100	56	25	2
HWD190R3WD25M	HWD190R5WD25M	19.000	0.7480	19.500	0.7677	60	100	56	25	2
HWD195R3WD25M	HWD195R5WD25M	19.500	0.7677	19.999	0.7873	60	100	56	25	2
HWD200R3WD25M	HWD200R5WD25M	20.000	0.7874	20.500	0.8071	60	100	56	25	3
HWD205R3WD25M	HWD205R5WD25M	20.500	0.8071	21.000	0.8268	66	110	56	25	3
HWD210R3WD25M	HWD210R5WD25M	21.000	0.8268	21.500	0.8465	66	110	56	25	3
HWD215R3WD25M	HWD215R5WD25M	21.500	0.8465	22.000	0.8661	66	110	56	25	3
HWD220R3WD25M	HWD220R5WD25M	22.000	0.8661	22.000	0.8661	66	110	56	25	3
—	HWD221R5WD25M	22.010	0.8665	22.500	0.8858	—	120	56	25	4

• This tool holder has internal coolant

• holder should use correct inserts, Inserts to be ordered separa

• For information on adapting screw wrenches, see page C61; for usage, see page C62

HWD-R3/R5



HEAD CHANGABLE DRILL HOLDER

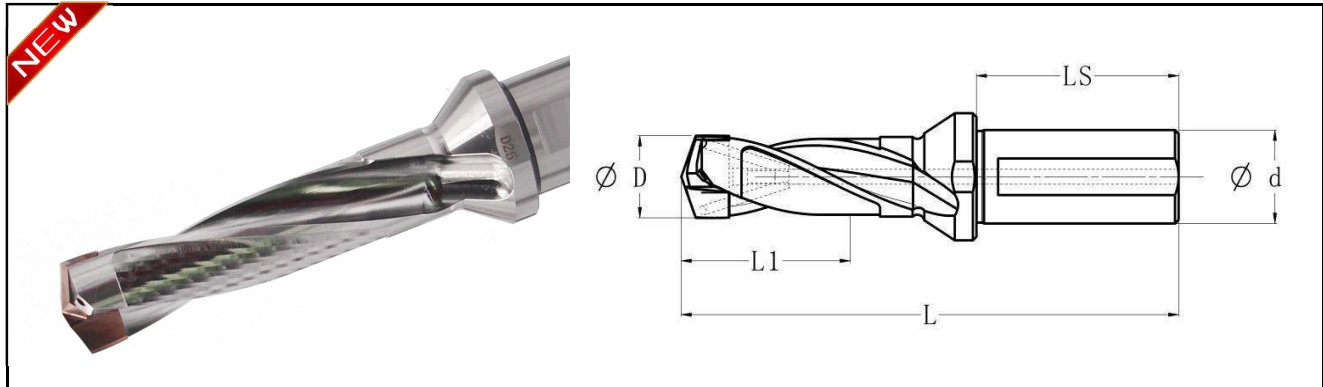

• HWD • 3 x D / 5 x D • METRIC

PRODUCT MODEL	PRODUCT MODEL	DIMENSION								
		D		Dmax		L1		LS	d	SIZE
3 x D	5 x D	mm	in	mm	in	3XD	5XD			
HWD225R3WD25M	HWD225R5WD25M	22.500	0.8858	23.000	0.9055	72	120	56	25	4
HWD230R3WD25M	HWD230R5WD25M	23.000	0.9055	23.500	0.9252	72	120	56	25	4
HWD235R3WD25M	HWD235R5WD25M	23.500	0.9252	24.000	0.9448	72	120	56	25	4
HWD240R3WD25M	HWD240R5WD25M	24.000	0.9449	24.000	0.9448	72	120	56	25	4
—	HWD241R5WD32M	24.010	0.9453	24.500	0.9646	—	130	60	32	5
HWD245R3WD32M	HWD245R5WD32M	24.500	0.9646	25.000	0.9843	78	130	60	32	5
HWD250R3WD32M	HWD250R5WD32M	25.000	0.9843	25.500	1.0039	78	130	60	32	5
HWD255R3WD32M	HWD255R5WD32M	25.500	1.0039	26.000	1.0236	78	130	60	32	5
HWD260R3WD32M	HWD260R5WD32M	26.000	1.0236	26.000	1.0236	78	130	60	32	5
—	HWD261R5WD32M	26.010	1.0240	26.500	1.0433	—	140	60	32	6
HWD265R3WD32M	HWD265R5WD32M	26.500	1.0433	27.000	1.0630	84	140	60	32	6
HWD270R3WD32M	HWD270R5WD32M	27.000	1.0630	27.500	1.0827	84	140	60	32	6
HWD275R3WD32M	HWD275R5WD32M	27.500	1.0827	28.000	1.1023	84	140	60	32	6
HWD280R3WD32M	HWD280R5WD32M	28.000	1.1024	28.000	1.1023	84	140	60	32	6
—	HWD281R5WD32M	28.016	1.1030	28.500	1.1220	—	150	60	32	7
HWD285R3WD32M	HWD285R5WD32M	28.500	1.1220	29.000	1.1417	90	150	60	32	7
HWD290R3WD32M	HWD290R5WD32M	29.000	1.1417	29.500	1.1614	90	150	60	32	7
HWD295R3WD32M	HWD295R5WD32M	29.500	1.1614	30.000	1.1811	90	150	60	32	7
HWD300R3WD32M	HWD300R5WD32M	30.000	1.1811	30.000	1.1811	90	150	60	32	7
—	HWD301R5WD32M	30.010	1.1815	30.500	1.2008	—	160	60	32	8
HWD305R3WD32M	HWD305R5WD32M	30.500	1.2008	31.000	1.2205	96	160	60	32	8
HWD310R3WD32M	HWD310R5WD32M	31.000	1.2205	31.500	1.2402	96	160	60	32	8
HWD315R3WD32M	HWD315R5WD32M	31.500	1.2402	32.000	1.2598	96	160	60	32	8
HWD320R3WD32M	HWD320R5WD32M	32.000	1.2598	32.000	1.2598	96	160	60	32	8

• This tool holder has internal coolant

• holder should use correct inserts, Inserts to be ordered separately

• For information on adapting screw wrenches, see page C61; usage C62

HWD-R7/R10



HEAD CHANGABLE DRILL HOLDER

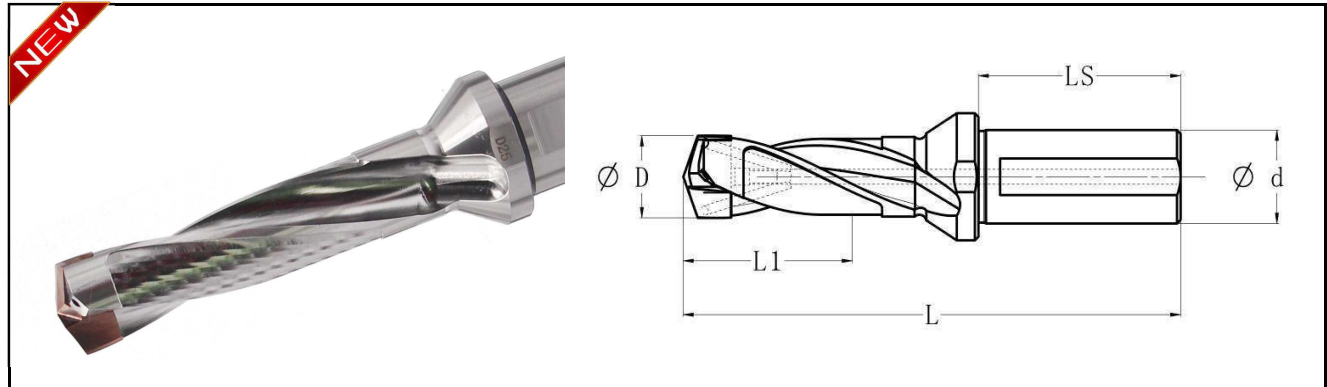

• HWD • 7 x D / 10 x D • METRIC

PRODUCT MODEL	PRODUCT MODEL	DIMENSION								
		D		Dmax		L1		LS	d	SIZE
7 x D	10 x D	mm	in	mm	in	7XD	10XD			
HWD125R7WD16M	HWD125R10WD16M	12.500	0.4921	13.000	0.5118	98	125	48	16	C
HWD130R7WD16M	HWD130R10WD16M	13.000	0.5118	13.500	0.5314	98	130	48	16	C
HWD135R7WD16M	HWD135R10WD16M	13.500	0.5315	13.500	0.5314	98	135	48	16	C
HWD136R7WD16M	HWD136R10WD16M	13.510	0.5319	14.000	0.5512	98	135	48	16	B
HWD140R7WD16M	HWD140R10WD16M	14.000	0.5512	14.500	0.5708	98	140	48	16	B
HWD145R7WD20M	HWD145R10WD20M	14.500	0.5709	14.500	0.5708	112	145	50	20	B
HWD146R7WD20M	HWD146R10WD20M	14.510	0.5713	15.000	0.5906	112	145	50	20	A
HWD150R7WD20M	HWD150R10WD20M	15.000	0.5906	15.500	0.6102	112	150	50	20	A
HWD155R7WD20M	HWD155R10WD20M	15.500	0.6102	15.874	0.6249	112	155	50	20	A
HWD160R7WD20M	HWD160R10WD20M	16.000	0.6299	16.500	0.6496	112	160	50	20	1
HWD165R7WD20M	HWD165R10WD20M	16.500	0.6496	17.000	0.6693	126	165	50	20	1
HWD170R7WD20M	HWD170R10WD20M	17.000	0.6693	17.500	0.6890	126	170	50	20	1
HWD175R7WD20M	HWD175R10WD20M	17.500	0.6890	18.000	0.7086	126	175	50	20	1
HWD180R7WD20M	HWD180R10WD20M	18.000	0.7087	18.000	0.7086	126	180	50	20	1
—	HWD181R10WD25M	18.010	0.7091	18.500	0.7283	—	185	56	25	2
HWD185R7WD25M	HWD185R10WD25M	18.500	0.7283	19.000	0.7480	140	185	56	25	2
HWD190R7WD25M	HWD190R10WD25M	19.000	0.7480	19.500	0.7677	140	190	56	25	2
HWD195R7WD25M	HWD195R10WD25M	19.500	0.7677	19.999	0.7873	140	195	56	25	2
HWD200R7WD25M	HWD200R10WD25M	20.000	0.7874	20.500	0.8071	140	200	56	25	3
HWD205R7WD25M	HWD205R10WD25M	20.500	0.8071	21.000	0.8268	154	205	56	25	3
HWD210R7WD25M	HWD210R10WD25M	21.000	0.8268	21.500	0.8465	154	210	56	25	3
HWD215R7WD25M	HWD215R10WD25M	21.500	0.8465	22.000	0.8661	154	215	56	25	3
HWD220R7WD25M	HWD220R10WD25M	22.000	0.8661	22.000	0.8661	154	220	56	25	3
—	HWD221R10WD25M	22.010	0.8665	22.500	0.8858	—	225	56	25	4

• This tool holder has internal coolant

• holder should use correct inserts, Inserts to be ordered separate

• For information on adapting screw wrenches, see page C61; for usage, see page C62

HWD-R7/R10



HEAD CHANGABLE DRILL HOLDER

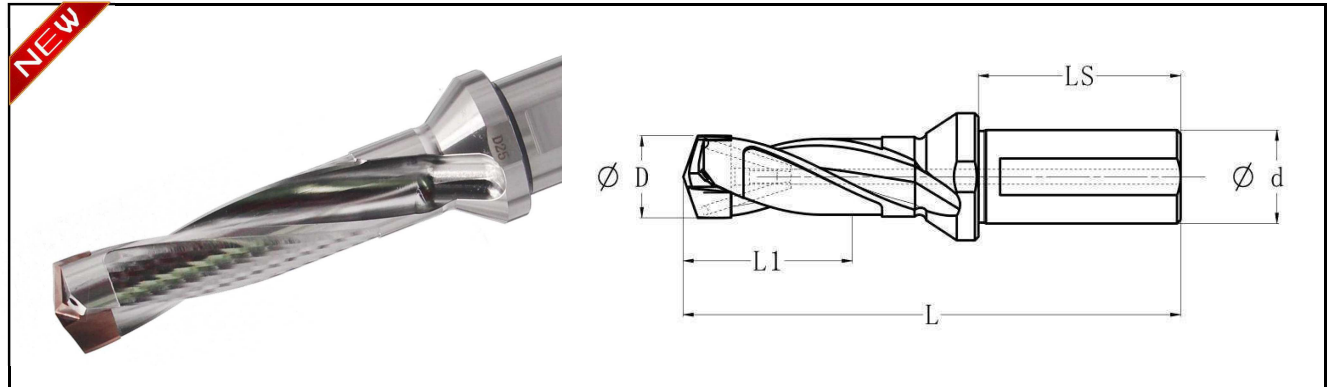

• CDH • 7 x D / 10 x D • METRIC

PRODUCT MODEL	PRODUCT MODEL	DIMENSION								
		D		Dmax		L1		LS	d	刀座尺寸
7 x D	10 x D	mm	in	mm	in	7XD	10XD			
HWD225R7WD25M	HWD225R10WD25M	22.500	0.8858	23.000	0.9055	168	225	56	25	4
HWD230R7WD25M	HWD230R10WD25M	23.000	0.9055	23.500	0.9252	168	230	56	25	4
HWD235R7WD25M	HWD235R10WD25M	23.500	0.9252	24.000	0.9448	168	235	56	25	4
HWD240R7WD25M	HWD240R10WD25M	24.000	0.9449	24.000	0.9448	168	240	56	25	4
—	HWD241R10WD32M	24.010	0.9453	24.500	0.9646	—	245	60	32	5
HWD245R7WD32M	HWD245R10WD32M	24.500	0.9646	25.000	0.9843	182	245	60	32	5
HWD250R7WD32M	HWD250R10WD32M	25.000	0.9843	25.500	1.0039	182	250	60	32	5
HWD255R7WD32M	HWD255R10WD32M	25.500	1.0039	26.000	1.0236	182	255	60	32	5
HWD260R7WD32M	HWD260R10WD32M	26.000	1.0236	26.000	1.0236	182	260	60	32	5
—	HWD261R10WD32M	26.010	1.0240	26.500	1.0433	—	265	60	32	6
HWD265R7WD32M	HWD265R10WD32M	26.500	1.0433	27.000	1.0630	196	265	60	32	6
HWD270R7WD32M	HWD270R10WD32M	27.000	1.0630	27.500	1.0827	196	270	60	32	6
HWD275R7WD32M	HWD275R10WD32M	27.500	1.0827	28.000	1.1023	196	275	60	32	6
HWD280R7WD32M	HWD280R10WD32M	28.000	1.1024	28.000	1.1023	196	280	60	32	6
—	HWD281R10WD32M	28.016	1.1030	28.500	1.1220	—	285	60	32	7
HWD285R7WD32M	HWD285R10WD32M	28.500	1.1220	29.000	1.1417	210	285	60	32	7
HWD290R7WD32M	HWD290R10WD32M	29.000	1.1417	29.500	1.1614	211	290	60	32	7
HWD295R7WD32M	HWD295R10WD32M	29.500	1.1614	30.000	1.1811	212	295	60	32	7
HWD300R7WD32M	HWD300R10WD32M	30.000	1.1811	30.000	1.8110	213	300	60	32	7
—	HWD301R10WD32M	30.010	1.1815	30.500	1.2008	—	305	60	32	8
HWD305R7WD32M	—	30.500	1.2008	31.000	1.2205	224	—	60	32	8
HWD310R7WD32M	HWD310R10WD32M	31.000	1.2205	31.500	1.2402	224	310	60	32	8
HWD315R7WD32M	—	31.500	1.2402	32.000	1.2598	224	—	60	32	8
HWD320R7WD32M	HWD320R10WD32M	32.000	1.2598	32.000	1.2598	224	320	60	32	8

•This tool holder has internal coolant

•holder should use correct inserts, Inserts to be ordered separa

•For information on adapting screw wrenches, see page C61; f

HEAD CHANGABLE DRILL HOLDER ACCESSORY

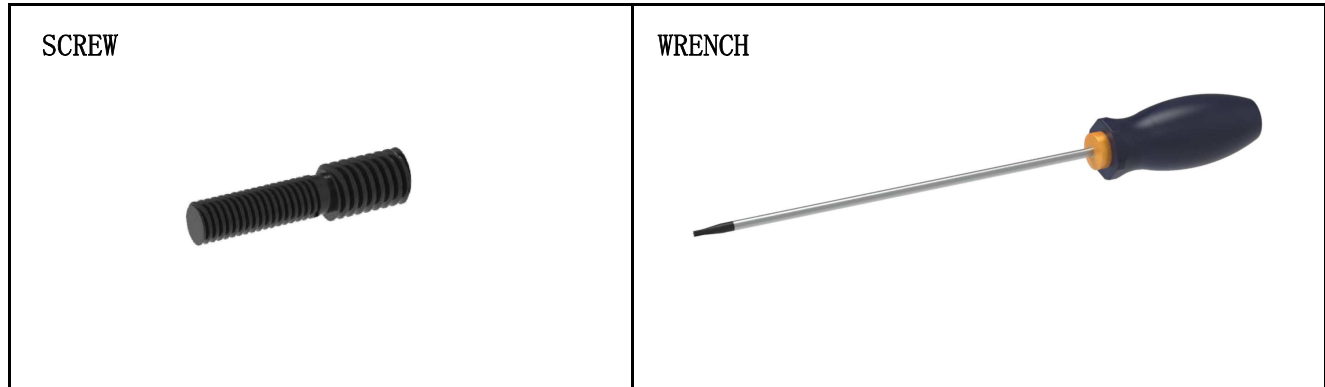

PRODUCT DIA	HOLDER SIZE	SCREW	WRENCH (x DIA)				
			1XD	3XD	5XD	7XD	10XD
12.50 - 13.50	C	CLD02502513	CBLT5156	CBLT5156	CBLT5156	CBLT5188	CBLT5290
13.51 - 14.50	B	CLD0250316	CBLT6156	CBLT6156	CBLT6156	CBLT6188	CBLT6290
14.51 - 15.87	A	CLD0250316	CBLT6156	CBLT6156	CBLT6156	CBLT6188	CBLT6290
15.88 - 18.00	1	CLD02503516	CBL015185	CBL015185	CBL015185	CBL015225	CBL015297
18.01 - 19.99	2	CLD02503516	CBL015185	CBL015185	CBL015185	CBL015225	CBL015297
20.00 - 22.00	3	CLD030419	CBL020210	CBL020210	CBL020210	CBL020260	CBL020260
22.01 - 24.00	4	CLD030419	CBL020210	CBL020210	CBL020210	CBL020260	CBL020260
24.01 - 26.00	5	CLD040523	CBL025240	CBL025240	CBL025240	CBL025240	CBL025295
26.01 - 28.00	6	CLD040523	CBL025240	CBL025240	CBL025240	CBL025240	CBL025295
28.01 - 30.00	7	CLD050628	CBL030265	CBL030265	CBL030265	CBL030265	CBL030265
30.01 - 32.00	8	CLD050628	CBL030265	CBL030265	CBL030265	CBL030265	CBL030265



Fine boring unit



Application example of fine boring unit

1: High Precision Compound Holes

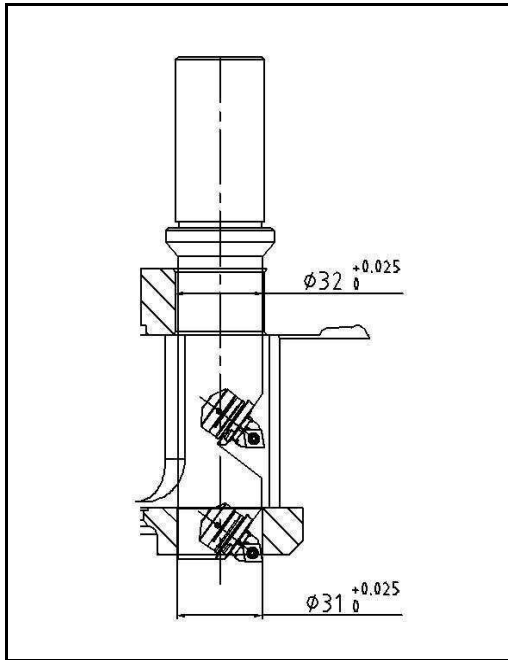

2: Through hole back boring hole

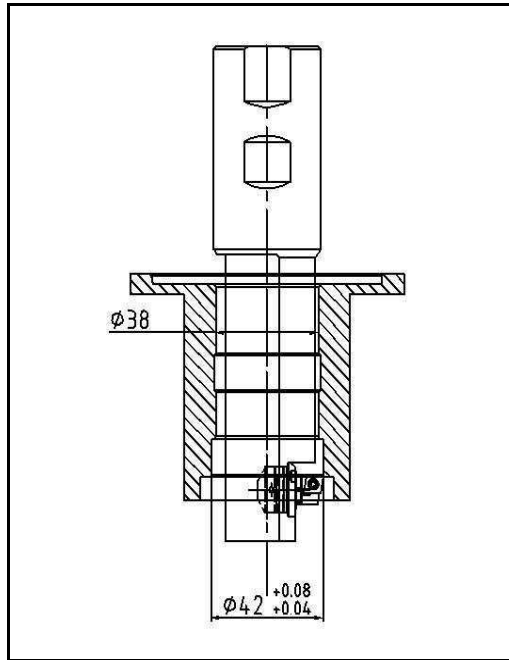

3: Sleeve boring outer surface

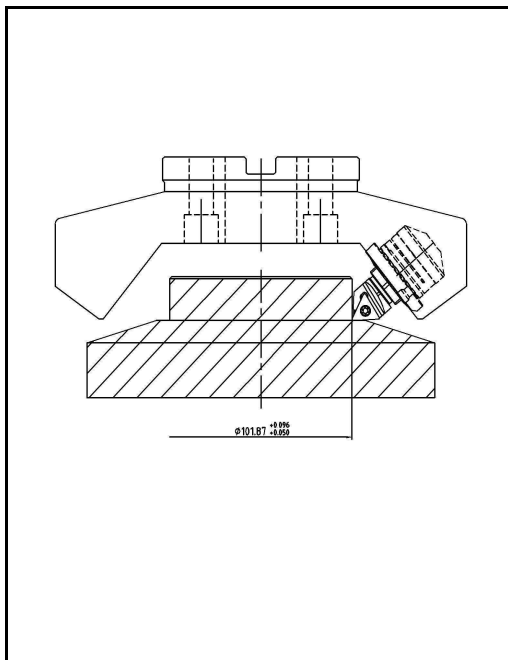

4: Rough&fine composite tool

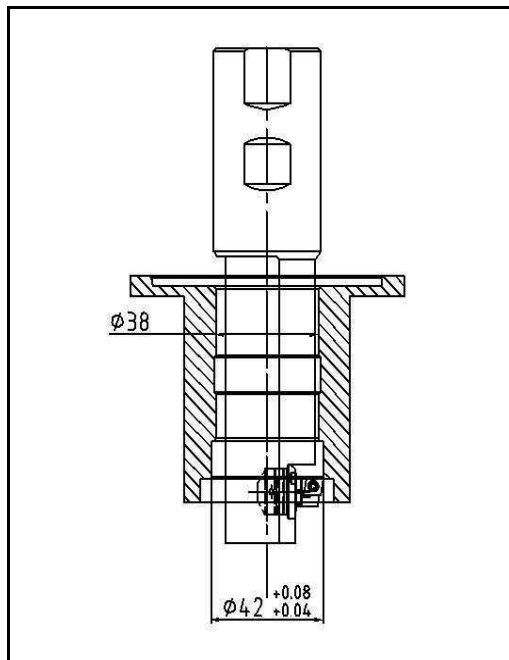

HWB-WRH



ROUGH BORING CUTTER MODULE

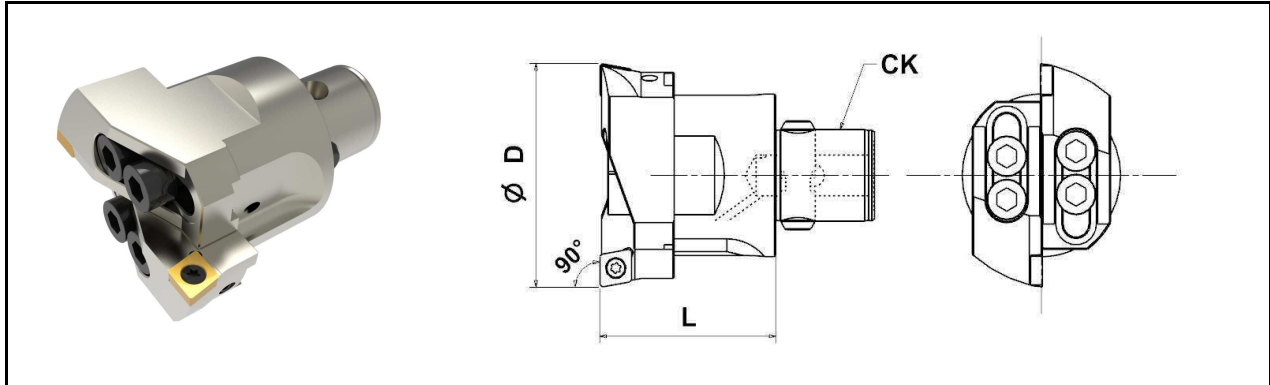

MODEL	BORING φ D (mm)	Insert holder model	CONNE CTOR	L	Kg	INSERTS
HWB-WRH2026-CKB1	20~26	WRH-2026-CC06	CK1	32.5	0.1	CC...06
HWB-WRH2533-CKB2	25~33	WRH-2533-CC06	CK2	35.5	0.2	
HWB-WRH3242-CKB3	32~42	WRH-3242-CC09	CK3	40	0.3	
HWB-WRH4154-CKB4	41~54	WRH-4154-CC09	CK4	47	0.5	CC...09
HWB-WRH5370-CKB5	53~70	WRH-5370-CC12	CK5	57	0.8	
HWB-WRH6890-CKB6	68~90	WRH-6890-CC12	CK6	71	1.6	CC...12
HWB-WRH88110-CKB6	88~110	WRH-88110-CC12			1.8	
HWB-WRH98126-CKB6	98~126	WRH-98126-CC12			2.8	
HWB-WRH125153-CKB6	125~153	WRH-125153-CC12			3.0	
HWB-WRH98126-CKB7	98~126	WRH-98126-CC12			CK7	
HWB-WRH125153-CKB7	125~153	WRH-125153-CC12	4.1			
HWB-WRH148176-CKB6	148~176	WRH-148176-CC12	CK6	71	3.6	
HWB-WRH175203-CKB6	175~203	WRH-175203-CC12			3.8	
HWB-WRH148176-CKB7	148~176	WRH-148176-CC12	CK7	117	6.4	
HWB-WRH175203-CKB7	175~203	WRH-175203-CC12			6.6	

©Standard cutter head

©With corresponding blade holder

©INSERT to be ordered separately

WRH



Rough boring cartridge

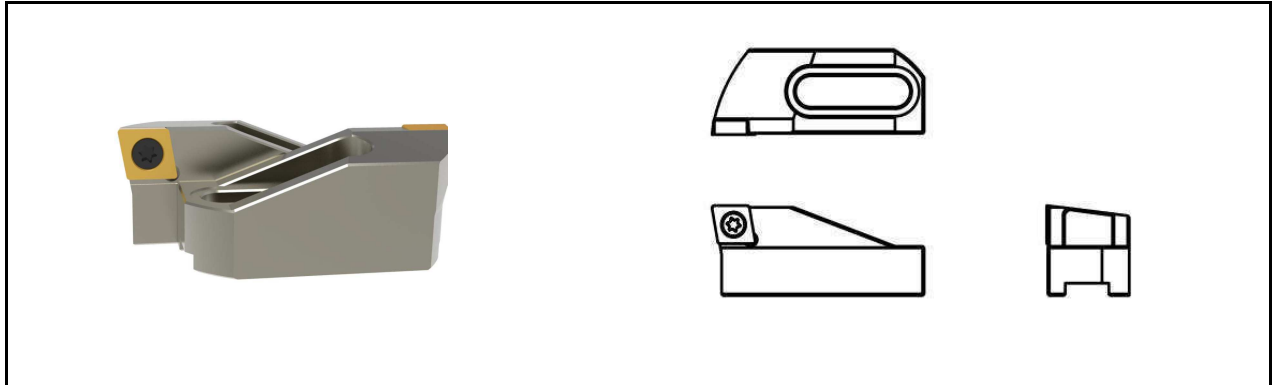

Insert holder model	RANGE ϕD (mm)	Kr	INSERT	INSERT SCREW	WRENCH
WRH-2026-CC06	20~26	90°	CC06	CSG2565-P	CTS08W-P
WRH-2533-CC06	25~33				
WRH-3242-CC09	32~42		CC09	CSG4011-P	CTS15W-P
WRH-4154-CC09	41~54				
WRH-5370-CC12	53~70		CC12	CSG5012-P	CTS20W-P
WRH-6890-CC12	68~90				
WRH-88110-CC12	88~110				
WRH-98126-CC12	98~126				
WRH-125153-CC12	125~153				
WRH-148176-CC12	148~176				
WRH-175203-CC12	175~203				

©INSERT to be ordered separately



SCFCR/L



CLAMP

SCFCR/L, 90°

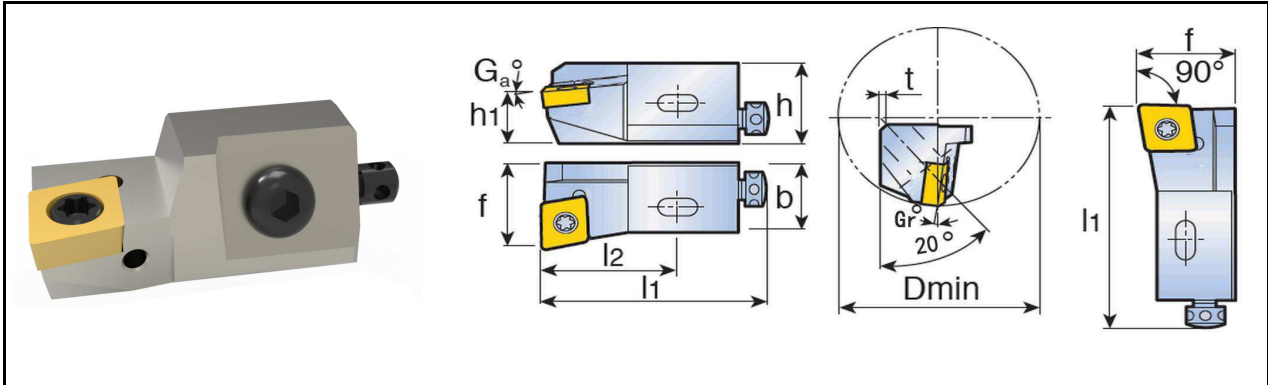

MODEL	L/R	DIMENSIONS									INSERTS
		h	h1	b	l1	l2	f	Gr	t	Dmin	
SCFCR 08CA-06	RIGHT	11	8	8	32	15	10	—	—	25	CC...0602
SCFCR 10CA-09		15	10	11	50	30	14	—	—	40	CC...09T3
SCFCR 12CA-09		20	12	16	55	35	20	—	—	50	CC...09T3
SCFCR 12CA-12		20	12	16	55	47	20	-3	6	50	CC...1204
SCFCL 08CA-06	LEFT	11	8	8	32	15	10	—	—	25	CC...0602
SCFCL 10CA-09		15	10	11	50	30	14	—	—	40	CC...09T3
SCFCL 12CA-09		20	12	16	55	35	20	—	—	50	CC...09T3
SCFCL 12CA-12		20	12	16	55	47	20	-3	6	50	CC...1204

©INSERT to be ordered separately

©For accessories and installation dimensions, see page D18

SSKCR/L, 75°

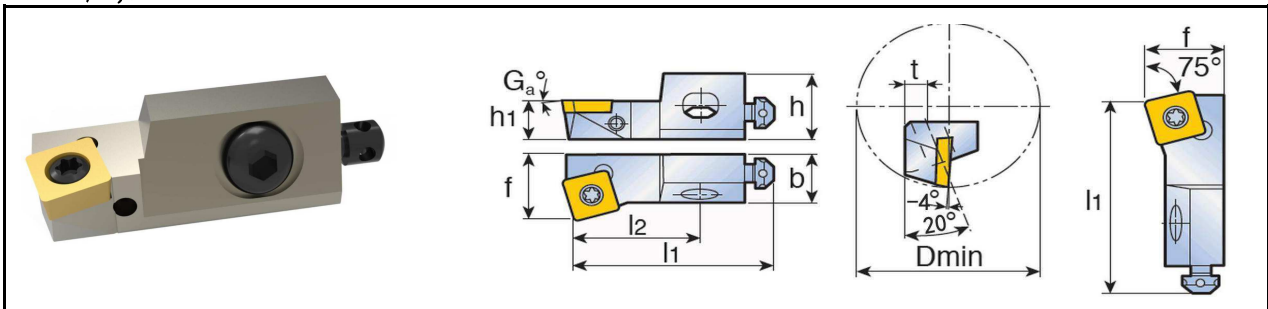

MODEL	L/R	DIMENSIONS									INSERTS
		h	h1	b	l1	l2	f	Ga	t	Dmin	
SSKCR 10CA-09	RIGHT	15	10	11	50	30	14	-1	5	40	SC...09T3
SSKCR 12CA-12		20	12	15	55	35	20	-1	6	50	SC...1204
SSKCL 10CA-09	LEFT	15	10	11	50	30	14	-1	5	40	SC...09T3
SSKCL 12CA-12		20	12	15	55	35	20	-1	6	50	SC...1204

©INSERT to be ordered separately; For accessories and installation dimensions, see page D18

SSKCR/L、SSSCR/L



CLAMP

SSSCR/L, 45°

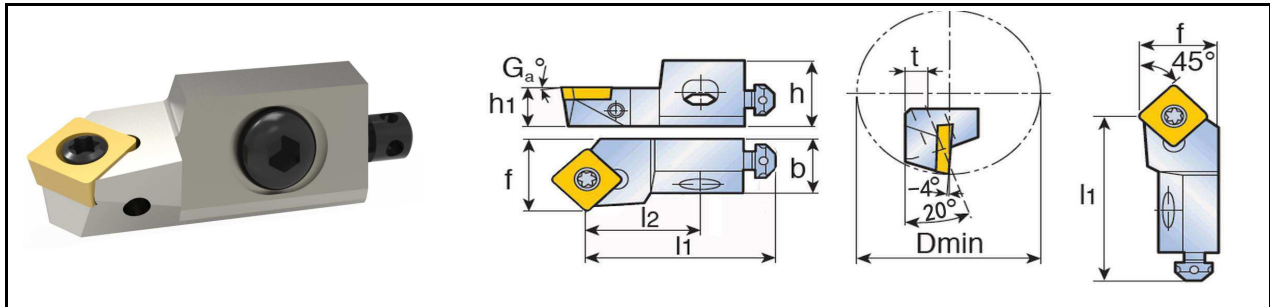

MODEL	L/R	DIMENSIONS									INSERTS
		h	h1	b	l1	l2	f	Ga	t	Dmin	
SSSCR 10CA-09	RIGHT	15	10	11	44	24	14	-4	5	40	SC...09T3
SSSCR 12CA-12		20	12	15	47	27	20	-4	6	50	SC...1204
SSSCL 10CA-09	LEFT	15	10	11	44	24	14	-4	5	40	SC...09T3
SSSCL 12CA-12		20	12	15	47	27	20	-4	6	50	SC...1204

©INSERT to be ordered separately; . For acce

STFCR/L, 90°

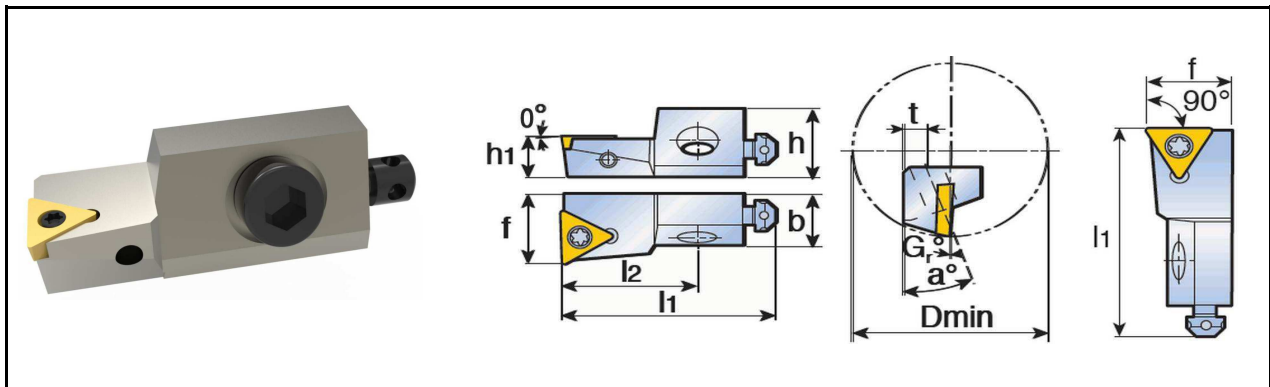

MODEL	L/R	DIMENSIONS									INSERTS
		h	h1	b	l1	l2	f	Gr	t	Dmin	
STFCR 10CA 09	RIGHT	15	10	10	50	30	14	-3	5		TC...0902
STFCR 10CA 11		15	10	11	50	30	14	-3	5	40	TC...1102
STFCR 12CA 16		20	12	15	55	35	20	-3	6	50	TC...16T3
STFCR 16CA 16		21	16	20	63	38	25	-6	—	50	
STFCL 10CA 09	LEFT	15	10	10	50	30	14	-3	5		TC...0902
STFCL 10CA 11		15	10	11	50	30	14	-3	5	40	TC...1102
STFCL 12CA 16		20	12	15	55	35	20	-3	6	50	TC...16T3
STFCL 16CA 16		21	16	20	63	38	25	-6	—	50	

©INSERT to be ordered separately; . For acce

NOTE: 10CA , $\alpha = 20^\circ$

... 12CA , $\alpha = 20^\circ$

... 16CA , $\alpha = 45^\circ$

STFCR/L



CLAMP

INSERTS SCREW

INSERTS MODEL	SCREW	WRENCH	INSERTS MODEL	SCREW	WRENCH
CC...0602	CSC2560	CTS08W	SC...1204	CSC5012	CTS20W
CC...09T3	CSC4090	CTS15W	TC...0902	CSC2250	CTS07W
CC...1204	CSC5012	CTS20W	TC...1102	CSC2560	CTS08W
SC...09T3	CSC4090	CTS15W	TC...16T3	CSC4090	CTS15W

Tool holder accessories and installation dimensions

	CLAMP. MODEL	① SCREW	② WRENCH	③ RADI. SCREW	④ AXIAL SCREW	⑤ WRENCH
	06CA	CLB0350806	CBL23	CLZ390	CLC0300605	CBL15
	08CA	CLB0401607	CBL25	CLZ470	CLC0300605	CBL15
	10CA	CLB0602010	CBL40	CLZ470	CLC0400807	CBL20
	12CA	CLB0602510	CBL40	CLZ580	CLC0401207	CBL20
	16CA	CLB08030125	CBL50	CLZ618	CLC0401207	CBL20

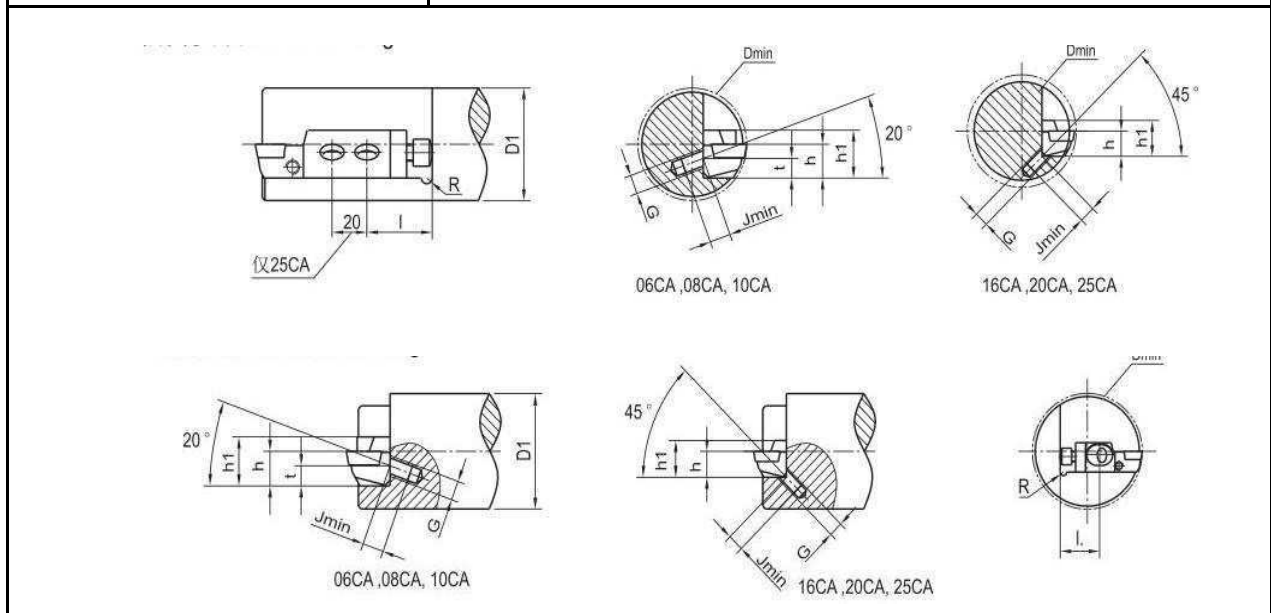

CLAMP. MODEL	h	l	G	Jmin	t	h1	Rmax	Dmin	D1
06CA	6	12	M3. 5X0. 6	10	3. 5	8. 5	2. 0	20	The maximum diameter of the shank is less than the diameter of the boring hole. by 3mm
08CA	8	17	M4X0. 7	10	4. 5	10	2. 5	25	
10CA	10	20	M6X1	14	5. 0	15	4. 0	40	
12CA	12	20	M6X1	14	6. 0	20	5. 0	50	
16CA	16	25	M8X1. 25	15	—	21	5. 0	55	
16CA	20	30	M8X1. 25	15	—	25	5. 0	70	

Steel Small Diameter Fine Boring

RANGE $\phi 6 - \phi 50$

Shank model	L	Kg
BT40-CK6-55	55	1.22
BT50-CK6-85	85	4.28
SK40-CK6-90	90	1.22
SK50-CK6-85	85	4.28
HSK A63-CK6-100	100	2.20
HSK A100-CK6-85	85	4.20

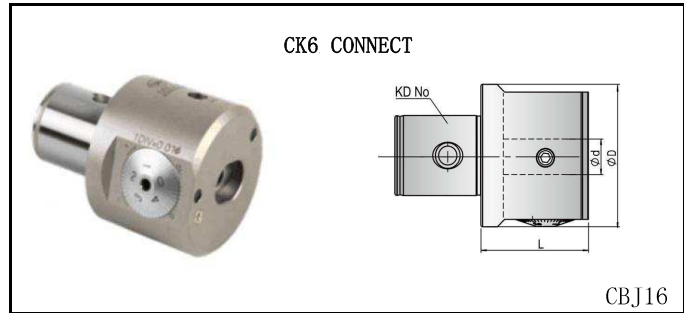

BORING MODEL	CK NO.	D	d	L	JOURNEY	W. kg
HBJ16	6	64	16	50	6	1.25

©Note that the tool holder, fine boring mechanism, and steel boring bars must be ordered separately

steel boring SHANK

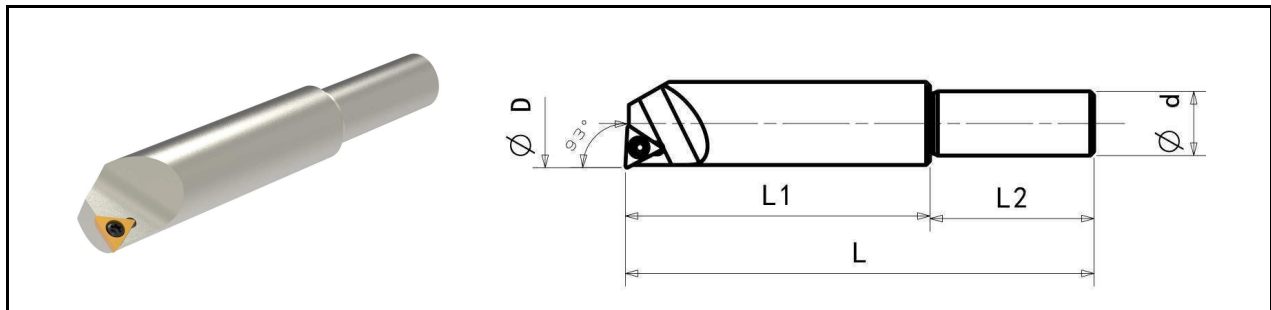

MODEL	RANGE	D	d	L1	L2	L	INSERT	SCREW/ WRENCH	W. kg	
HBJ1606-24	6-8	6	16	24	42	66	WBGT 0601	CSS2005 CTS06W	0.07	
HBJ1608-32	8-11	8		32	42	76	TBGT 0601		CSC2560 CTS08W	0.08
HBJ1610-40	10-13	10		40	42	77				TPGH 0902
HBJ1612-53	12-17	12		53	42	90	TPGH 1103	CSC3080 CTS10W		
HBJ1616-68	16-21	16		68	42	102			TPGH 1103	CSC3080 CTS10W
HBJ1620-83	20-26	20		83	42	120	TPGH 1103			
HBJ1620-90	25-32	25		90	38	124		TPGH 1103	CSC3080 CTS10W	
HBJ1630-90	30-42	30		90	38	124	TPGH 1103			CSC3080 CTS10W
HBJ1640-90	40-50	40		90	38	124		TPGH 1103		

©Standard shank without internal coolant

©INSERTS to be ordered separately

HWM



Super hard solid tungsten carbide boring bars

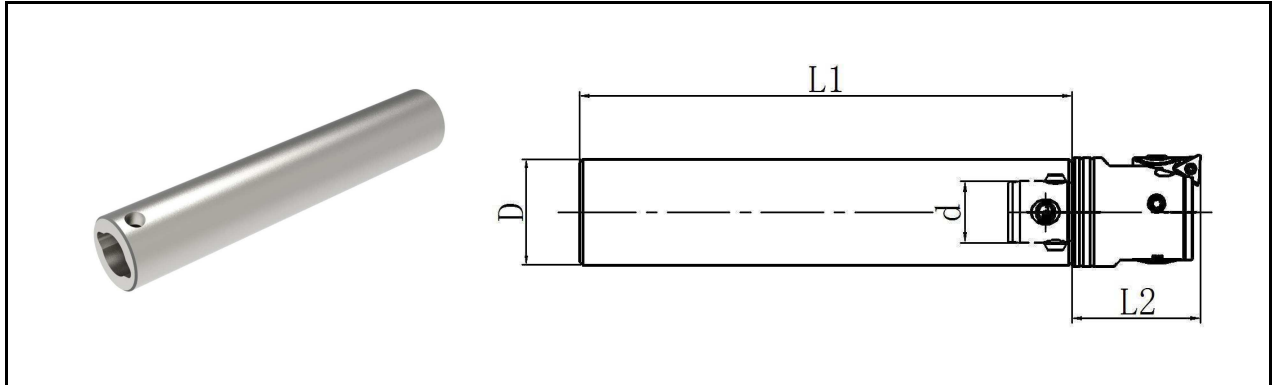

PRODUCT MODEL	SHANK	CONNE CT	DIMENSION (mm)				Kg
			D	d	L1	L2	
HWM-C19-CKB1-150 SCB		CK1	19	11	150	32.5	0.50
HWM-C19-CKB1-200	SCB	CK1	19	11	200	32.5	0.70
HWM-C19-CKB1-250	SCB	CK1	19	11	250	32.5	0.90
HWM-C24-CKB2-200	SCB	CK2	24	14	200	35.5	1.00
HWM-C24-CKB2-250	SCB	CK2	24	14	250	35.5	1.20
HWM-C24-CKB2-300	SCB	CK2	24	14	300	35.5	1.50
HWM-C32-CKB3-250	SCB	CK3	32	18	250	40	1.80
HWM-C32-CKB3-300	SCB	CK3	32	18	300	40	2.20
HWM-C32-CKB3-350	SCB	CK3	32	18	350	40	3.00

©high toughness, toughness and durability, high hardness, high rigidity, high shock resistance, can be used for deep hole machining (8D)

©Various specifications have water holes, and the chip removal and cooling effect are good in deep hole machining

©Straight shank results, the processing depth can be adjusted according to the processing needs

PPL



Steel CK CONNECT Boring Bars

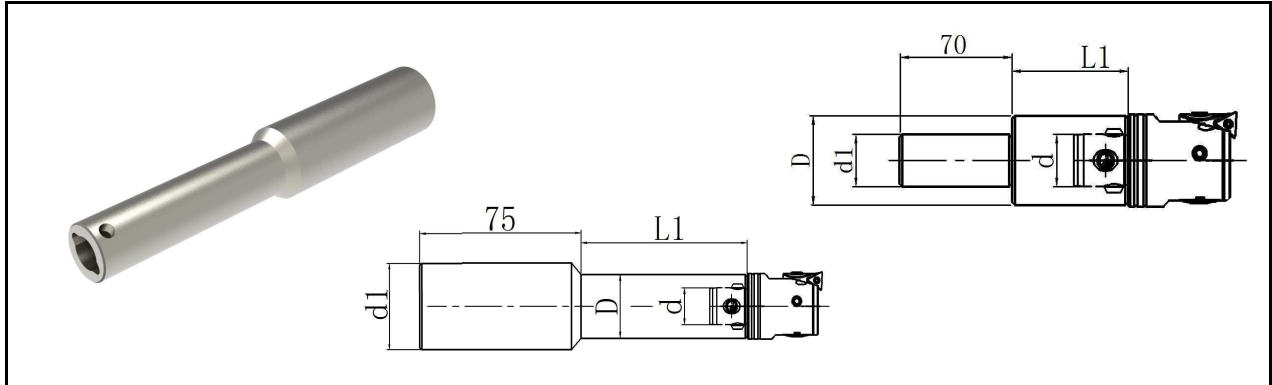

PRODUCT MODEL	hand type	CONNE CT	DIMENSION				Kg
			D	d	d1	L	
PPL-C32-CKB1-75	SSB	CK1	19	11	32	75	0.52
PPL-C32-CKB2-70	SSB	CK2	24	14	32	70	0.59
PPL-C32-CKB2-120	SSB	CK2	24	14	32	120	0.85
PPL-C32-CKB3-70	SSB	CK3	31	18	32	70	0.73
PPL-C32-CKB3-120	SSB	CK3	31	18	32	120	1.01
PPL-C32-CKB4-60	SSB	CK4	39	22	32	60	0.77
PPL-C32-CKB4-110	SSB	CK4	39	22	32	110	1.19
PPL-C32-CKB5-60	SSB	CK5	50	28	32	60	1.02
PPL-C32-CKB5-120	SSB	CK5	50	28	32	120	1.89
PPL-C32-CKB6-60	SSB	CK6	64	36	32	60	1.42
PPL-C32-CKB6-120	SSB	CK6	64	36	32	120	2.20

BT - CK



Boring tool holder series

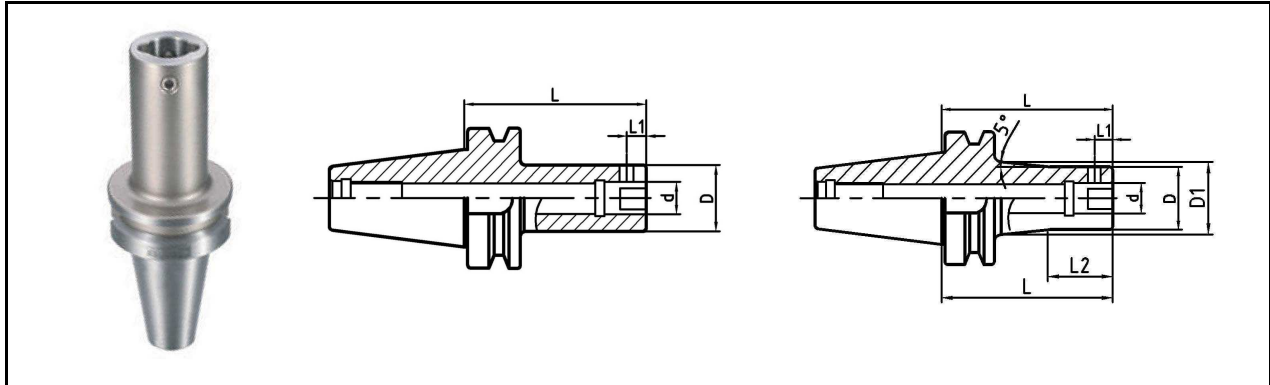

PRODUCT SERIES	TYPE	DIMENSION				PIC B DIM.		CKCK side screw	WRENC H	Kg
		D	d	L1	L	d1	L2			
BT40-CK1-70	CK1	19	11	5.05	70	—	—	M050Z050-30P-D	L025	1.03
BT40-CK1-100	CK1	19	11	5.05	100	20.7	60	M050Z050-30P-D	L025	1.10
BT40-CK2-75	CK2	24	14	6.62	75	—	—	M050Z060-30P-D	L025	1.10
BT40-CK2-100	CK2	24	14	6.62	100	—	—	M050Z060-30P-D	L025	1.18
BT40-CK2-130	CK2	24	14	6.62	130	30	65	M050Z060-30P-D	L025	1.33
BT40-CK3-80	CK3	31	18	8	80	—	—	M060Z090-30P-D	L03	1.22
BT40-CK3-100	CK3	31	18	8	100	—	—	M060Z090-30P-D	L03	1.32
BT40-CK3-135	CK3	31	18	8	135	34.5	75	M060Z090-30P-D	L03	1.54
BT40-CK3-165	CK3	31	18	8	165	39.7	85	M060Z090-30P-D	L03	1.76
BT40-CK4-70	CK4	39	22	10	70	—	—	M080Z120-30P-D	L04	1.21
BT40-CK4-100	CK4	39	22	10	100	—	—	M080Z120-30P-D	L04	1.46
BT40-CK4-150	CK4	39	22	10	150	43.4	85	M080Z120-30P-D	L04	1.90
BT40-CK4-170	CK4	39	22	10	170	46.9	95	M080Z120-30P-D	L04	2.16
BT40-CK5-60	CK5	50	28	13	60	—	—	M100Z160-30P-D	L05	1.22
BT40-CK5-80	CK5	50	28	13	80	—	—	M100Z160-30P-D	L05	1.52
BT40-CK5-100	CK5	50	28	13	100	—	—	M100Z160-30P-D	L05	1.80
BT40-CK5-150	CK5	50	28	13	150	—	—	M100Z160-30P-D	L05	2.52
BT40-CK5-180	CK5	50	28	13	180	—	—	M100Z160-30P-D	L05	2.90
BT40-CK6-55	CK6	64	36	16	55	—	—	M120Z200-30P-D	L06	1.22
BT40-CK6-100	CK6	64	36	16	100	—	—	M120Z200-30P-D	L06	2.29
BT40-CK6-150	CK6	64	36	16	150	—	—	M120Z200-30P-D	L06	3.50
BT40-CK6-180	CK6	64	36	16	180	—	—	M120Z200-30P-D	L06	4.22
BT40-CK7-100	CK7	90	46	19.15	100	—	—	M200Z290-30P-D	L10	3.50
BT40-CK7-150	CK7	90	46	19.15	150	—	—	M200Z290-30P-D	L10	5.50

BT - CK



Boring tool holder

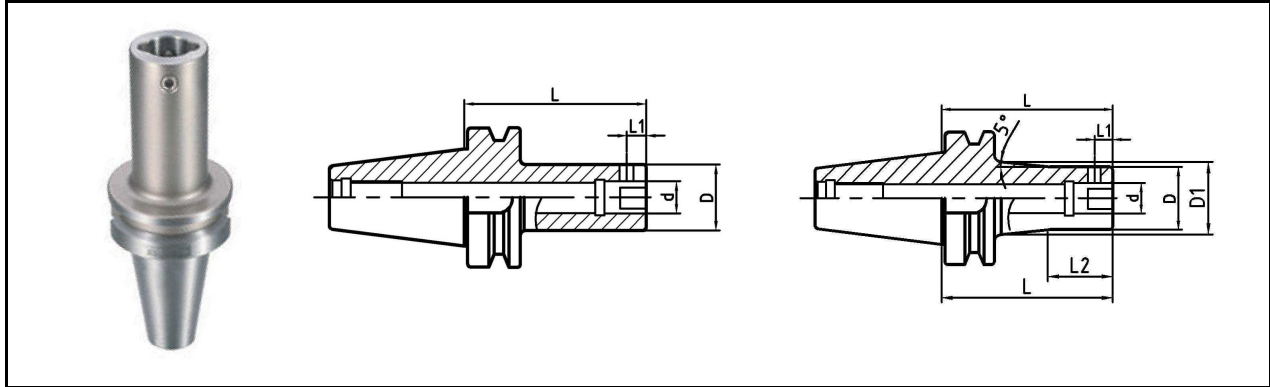

PRODUCT SERIES	TYPE	DIMENSION				PIC B DIM.		CKCK side screw	WRENC H	Kg
		D	d	L1	L	d1	L2			
BT50-CK1-80	CK1	19	11	5.05	80	—	—	M050Z050-30P-D	L025	3.20
BT50-CK1-115	CK1	19	11	5.05	115	20.7	50	M050Z050-30P-D	L025	3.73
BT50-CK2-80	CK2	24	14	6.62	80	—	—	M050Z060-30P-D	L025	3.68
BT50-CK2-105	CK2	24	14	6.62	105	—	—	M050Z060-30P-D	L025	3.78
BT50-CK2-135	CK2	24	14	6.62	135	26.6	65	M050Z060-30P-D	L025	3.89
BT50-CK3-85	CK3	31	18	8	85	—	—	M060Z090-30P-D	L03	3.80
BT50-CK3-110	CK3	31	18	8	110	—	—	M060Z090-30P-D	L03	3.95
BT50-CK3-140	CK3	31	18	8	140	32.7	75	M060Z090-30P-D	L03	4.09
BT50-CK3-170	CK3	31	18	8	170	38	85	M060Z090-30P-D	L03	4.31
BT50-CK4-100	CK4	39	22	10	100	—	—	M080Z120-30P-D	L04	3.98
BT50-CK4-160	CK4	39	22	10	160	42.5	85	M080Z120-30P-D	L04	4.50
BT50-CK4-205	CK4	39	22	10	205	50	95	M080Z120-30P-D	L04	5.13
BT50-CK5-90	CK5	50	28	13	90	—	—	M100Z160-30P-D	L05	4.30
BT50-CK5-165	CK5	50	28	13	165	—	—	M100Z160-30P-D	L05	5.20
BT50-CK5-210	CK5	50	28	13	210	57.8	120	M100Z160-30P-D	L05	5.92
BT50-CK5-270	CK5	50	28	13	270	68.4	120	M100Z160-30P-D	L05	7.23
BT50-CK6-85	CK6	64	36	16	85	—	—	M120Z200-30P-D	L06	4.28
BT50-CK6-155	CK6	64	36	16	155	—	—	M120Z200-30P-D	L06	5.97
BT50-CK6-215	CK6	64	36	16	215	—	—	M120Z200-30P-D	L06	7.43
BT50-CK6-250	CK6	64	36	16	250	—	—	M120Z200-30P-D	L06	8.27
BT50-CK6-300	CK6	64	36	16	300	80.5	160	M120Z200-30P-D	L06	10.21
BT50-CK6-350	CK6	64	36	16	350	90	160	M120Z200-30P-D	L06	12.90
BT50-CK7-85	CK7	90	36	19.15	85	—	—	M200Z290-30P-D	L10	4.96
BT50-CK7-150	CK7	90	36	19.15	150	—	—	M200Z290-30P-D	L10	6.52
BT50-CK7-210	CK7	90	36	19.15	210	—	—	M200Z290-30P-D	L10	8.55
BT50-CK7-250	CK7	90	36	19.15	250	—	—	M200Z290-30P-D	L10	10.35
BT50-CK7-300	CK7	90	36	19.15	300	—	—	M200Z290-30P-D	L10	12.55
BT50-CK7-350	CK7	90	36	19.15	350	—	—	M200Z290-30P-D	L10	13.25

SK-CK



Boring head holder

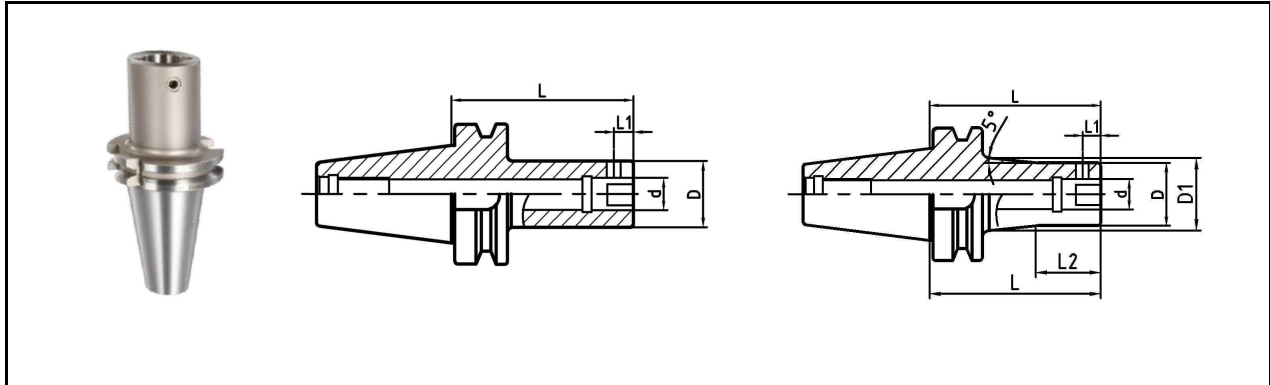

PRODUCT SERIES	TYPE	DIMENSION				PIC B DIM.		CKCK side screw	WRENC H	Kg
		D	d	L1	L	d1	L2			
SK40-CK1-70	CK1	19	11	5.05	70	—	—	M050Z050-30P-D	L025	1.03
SK40-CK1-100L	CK1	19	11	5.05	100	20.7	60	M050Z050-30P-D	L025	1.10
SK40-CK2-75	CK2	24	14	6.62	75	—	—	M050Z060-30P-D	L025	1.10
SK40-CK2-100	CK2	24	14	6.62	100	—	—	M050Z060-30P-D	L025	1.18
SK40-CK2-130L	CK2	24	14	6.62	130	28.3	75	M050Z060-30P-D	L025	1.33
SK40-CK3-80	CK3	31	18	8	80	—	—	M060Z090-30P-D	L03	1.22
SK40-CK3-100	CK3	31	18	8	100	—	—	M060Z090-30P-D	L03	1.32
SK40-CK3-135L	CK3	31	18	8	135	34.5	85	M060Z090-30P-D	L03	1.54
SK40-CK3-165L	CK3	31	18	8	165	39.7	85	M060Z090-30P-D	L03	1.76
SK40-CK4-70	CK4	39	22	10	70	—	—	M080Z120-30P-D	L04	1.21
SK40-CK4-100	CK4	39	22	10	100	—	—	M080Z120-30P-D	L04	1.46
SK40-CK4-150L	CK4	39	22	10	150	43.4	95	M080Z120-30P-D	L04	1.90
SK40-CK4-170L	CK4	39	22	10	170	46.9	95	M080Z120-30P-D	L04	2.16
SK40-CK5-80	CK5	50	28	13	80	—	—	M100Z160-30P-D	L05	1.52
SK40-CK5-100	CK5	50	28	13	100	—	—	M100Z160-30P-D	L05	1.80
SK40-CK5-150	CK5	50	28	13	150	—	—	M100Z160-30P-D	L05	2.52
SK40-CK5-180	CK5	50	28	13	180	—	—	M100Z160-30P-D	L05	2.90
SK40-CK6-90	CK6	64	36	16	90	—	—	M120Z200-30P-D	L06	1.22
SK40-CK6-150	CK6	64	36	16	150	—	—	M120Z200-30P-D	L06	3.50
SK40-CK6-180	CK6	64	36	16	180	—	—	M120Z200-30P-D	L06	4.22
SK40-CK7-100	CK7	90	46	19.15	100	—	—	M200Z290-30P-D	L10	3.50
SK40-CK7-150	CK7	90	46	19.15	150	—	—	M200Z290-30P-D	L10	5.50

SK-CK



Boring head holder

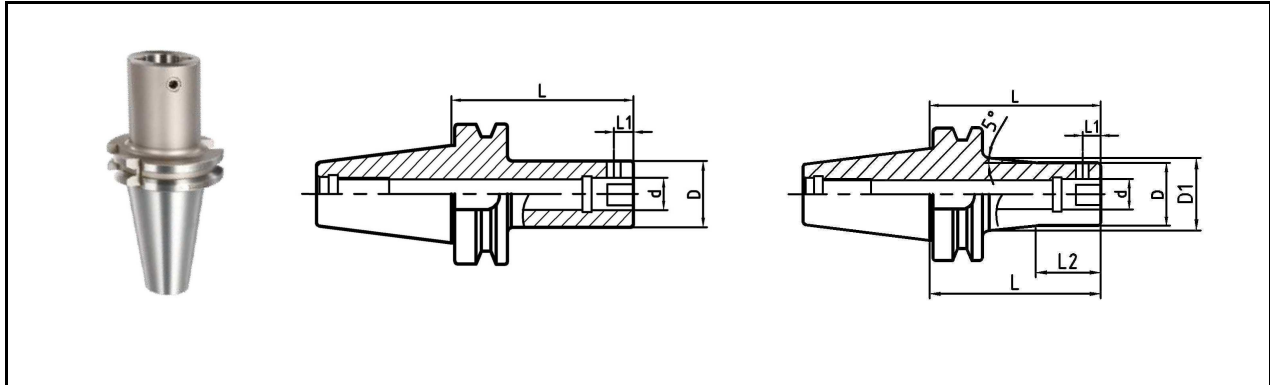

PRODUCT SERIES	TYPE	DIMENSION				PIC B DIM.		CKCK side screw	WRENC H	Kg
		D	d	L1	L	d1	L2			
SK50-CK1-80	CK1	19	11	5.05	80	—	—	M050Z050-30P-D	L025	3.60
SK50-CK1-115L	CK1	19	11	5.05	115	20.7	60	M050Z050-30P-D	L025	3.73
SK50-CK2-80	CK2	24	14	6.62	80	—	—	M050Z060-30P-D	L025	3.60
SK50-CK2-105	CK2	24	14	6.62	105	—	—	M050Z060-30P-D	L025	3.78
SK50-CK2-135L	CK2	24	14	6.62	135	26.6	75	M050Z060-30P-D	L025	3.89
SK50-CK3-85	CK3	31	18	8	85	—	—	M060Z090-30P-D	L03	3.80
SK50-CK3-110	CK3	31	18	8	110	—	—	M060Z090-30P-D	L03	3.95
SK50-CK3-140L	CK3	31	18	8	140	32.7	85	M060Z090-30P-D	L03	4.09
SK50-CK3-170L	CK3	31	18	8	170	38	85	M060Z090-30P-D	L03	4.31
SK50-CK4-100	CK4	39	22	10	100	—	—	M080Z120-30P-D	L04	3.98
SK50-CK4-160L	CK4	39	22	10	160	42.5	95	M080Z120-30P-D	L04	4.50
SK50-CK4-205L	CK4	39	22	10	205	50	95	M080Z120-30P-D	L04	5.13
SK50-CK5-90	CK5	50	28	13	90	—	—	M100Z160-30P-D	L05	4.30
SK50-CK5-165	CK5	50	28	13	165	—	—	M100Z160-30P-D	L05	5.20
SK50-CK5-210L	CK5	50	28	13	210	57.8	120	M100Z160-30P-D	L05	5.92
SK50-CK5-270L	CK5	50	28	13	270	68.4	120	M100Z160-30P-D	L05	7.23
SK50-CK6-85	CK6	64	36	16	85	—	—	M120Z200-30P-D	L06	4.28
SK50-CK6-155	CK6	64	36	16	155	—	—	M120Z200-30P-D	L06	5.97
SK50-CK6-215	CK6	64	36	16	215	—	—	M120Z200-30P-D	L06	7.43
SK50-CK6-250	CK6	64	36	16	250	—	—	M120Z200-30P-D	L06	8.27
SK50-CK6-300L	CK6	64	36	16	300	80.5	160	M120Z200-30P-D	L06	10.21
SK50-CK7-85	CK7	90	36	19.15	85	—	—	M200Z290-30P-D	L10	4.96
SK50-CK7-150	CK7	90	36	19.15	150	—	—	M200Z290-30P-D	L10	6.52
SK50-CK7-210	CK7	90	36	19.15	210	—	—	M200Z290-30P-D	L10	8.55
SK50-CK7-250	CK7	90	36	19.15	250	—	—	M200Z290-30P-D	L10	10.35
SK50-CK7-300	CK7	90	36	19.15	300	—	—	M200Z290-30P-D	L10	12.55
SK50-CK7-350	CK7	90	36	19.15	350	—	—	M200Z290-30P-D	L10	13.25

HSK A -CK



Boring tool holder

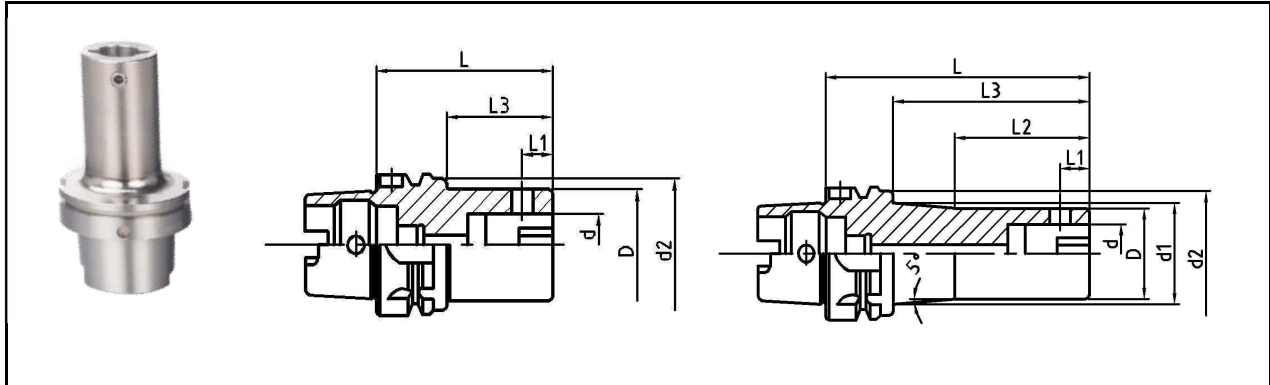

PRODUCT SERIES	TYPE	DIMENSION				PIC B DIM.		CKCK side screw	WRENC H	Kg
		D	d	L1	L	d1	L2			
HSKA63-CK1-70	CK1	19	11	5.05	70	—	—	M050Z050-30P-D	L025	0.80
HSKA63-CK1-100L	CK1	19	11	5.05	100	23.5	50	M050Z050-30P-D	L025	0.90
HSKA63-CK2-75	CK2	24	14	6.62	75	—	—	M050Z060-30P-D	L025	0.90
HSKA63-CK2-100	CK2	24	14	6.62	100	—	—	M050Z060-30P-D	L025	1.00
HSKA63-CK2-130L	CK2	24	14	6.62	130	31	65	M050Z060-30P-D	L025	1.10
HSKA63-CK3-80	CK3	31	18	8	80	—	—	M060Z090-30P-D	L03	1.00
HSKA63-CK3-100	CK3	31	18	8	100	—	—	M060Z090-30P-D	L03	1.10
HSKA63-CK3-135L	CK3	31	18	8	135	37	75	M060Z090-30P-D	L03	1.30
HSKA63-CK3-165L	CK3	31	18	8	165	41	85	M060Z090-30P-D	L03	1.40
HSKA63-CK4-70	CK4	39	22	10	70	—	—	M080Z120-30P-D	L04	1.00
HSKA63-CK4-100	CK4	39	22	10	100	—	—	M080Z120-30P-D	L04	1.30
HSKA63-CK4-150L	CK4	39	22	10	150	44	95	M080Z120-30P-D	L04	1.70
HSKA63-CK4-170L	CK4	39	22	10	170	47.5	95	M080Z120-30P-D	L04	1.90
HSKA63-CK5-80	CK5	50	28	13	80	—	—	M100Z160-30P-D	L05	1.40
HSKA63-CK5-100	CK5	50	28	13	100	—	—	M100Z160-30P-D	L05	1.80
HSKA63-CK5-150	CK5	50	28	13	150	—	—	M100Z160-30P-D	L05	2.20
HSKA63-CK5-180	CK5	50	28	13	180	—	—	M100Z160-30P-D	L05	2.70
HSKA63-CK6-100	CK6	64	36	16	100	—	—	M120Z200-30P-D	L06	2.20
HSKA63-CK6-150	CK6	64	36	16	150	—	—	M120Z200-30P-D	L06	2.80
HSKA63-CK6-180	CK6	64	36	16	180	—	—	M120Z200-30P-D	L06	3.30
HSKA63-CK7-110	CK7	90	46	19.15	110	—	—	M200Z290-30P-D	L10	3.50
HSKA63-CK7-150	CK7	90	46	19.15	150	—	—	M200Z290-30P-D	L10	5.20

HSK A -CK



Boring tool holder

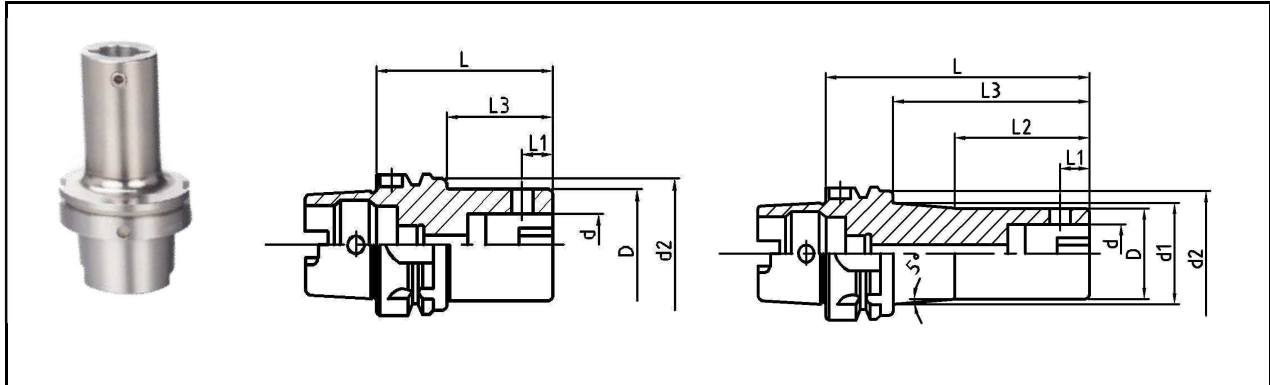

PRODUCT SERIES	TYPE	DIMENSION				PIC B DIM.		CKCK side screw	WRENC H	Kg
		D	d	L1	L	d1	L2			
HSKA100-CK1-80	CK1	19	11	5.05	80	—	—	M050Z050-30P-D	L025	2.40
HSKA100-CK1-115L	CK1	19	11	5.05	115	24	50	M050Z050-30P-D	L025	2.50
HSKA100-CK2-80	CK2	24	14	6.62	80	—	—	M050Z060-30P-D	L025	2.45
HSKA100-CK2-105	CK2	24	14	6.62	105	—	—	M050Z060-30P-D	L025	2.50
HSKA100-CK2-135L	CK2	24	14	6.62	135	30	65	M050Z060-30P-D	L025	2.60
HSKA100-CK3-85	CK3	31	18	8	85	—	—	M060Z090-30P-D	L03	2.60
HSKA100-CK3-110	CK3	31	18	8	110	—	—	M060Z090-30P-D	L03	2.70
HSKA100-CK3-140L	CK3	31	18	8	140	35.5	75	M060Z090-30P-D	L03	2.80
HSKA100-CK3-170L	CK3	31	18	8	170	41	85	M060Z090-30P-D	L03	2.90
HSKA100-CK4-100	CK4	39	22	10	100	—	—	M080Z120-30P-D	L04	2.80
HSKA100-CK4-160L	CK4	39	22	10	160	47	85	M080Z120-30P-D	L04	3.50
HSKA100-CK4-205L	CK4	39	22	10	205	50.5	110	M080Z120-30P-D	L04	4.00
HSKA100-CK5-90	CK5	50	28	13	90	—	—	M100Z160-30P-D	L05	3.50
HSKA100-CK5-165	CK5	50	28	13	165	—	—	M100Z160-30P-D	L05	4.20
HSKA100-CK5-210L	CK5	50	28	13	210	61	120	M100Z160-30P-D	L05	4.80
HSKA100-CK5-270L	CK5	50	28	13	270	69.5	130	M100Z160-30P-D	L05	5.60
HSKA100-CK6-85	CK6	64	36	16	85	—	—	M120Z200-30P-D	L06	4.20
HSKA100-CK6-155	CK6	64	36	16	155	—	—	M120Z200-30P-D	L06	5.00
HSKA100-CK6-215	CK6	64	36	16	215	—	—	M120Z200-30P-D	L06	5.80
HSKA100-CK6-250	CK6	64	36	16	250	—	—	M120Z200-30P-D	L06	6.20
HSKA100-CK6-300L	CK6	64	36	16	300	80	180	M120Z200-30P-D	L06	7.10
HSKA100-CK7-125	CK7	90	36	19.15	125	—	—	M200Z290-30P-D	L10	5.22
HSKA100-CK7-200	CK7	90	36	19.15	200	—	—	M200Z290-30P-D	L10	6.88
HSKA100-CK7-275	CK7	90	36	19.15	275	—	—	M200Z290-30P-D	L10	8.26

CK



Equal Diameter Extension Adapter

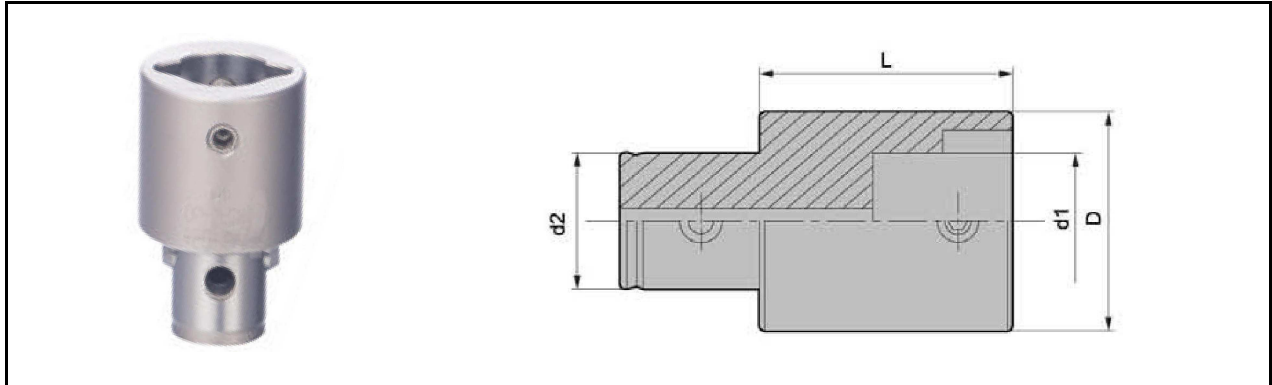

PRODUCT SERIES	TYPE	DIMENSION				CKCK side screw	WRENCH	Kg
		D	d1	d2	L			
CK1-1-30	CK1	19	11	11	30	M050Z050-30P-D	L025	0.06
CK2-2-30	CK2	24	14	14	30	M050Z060-30P-D	L025	0.09
CK3-3-30	CK3	31	18	18	30	M060Z090-30P-D	L03	0.14
CK4-4-45	CK4	39	22	22	45	M080Z120-30P-D	L04	0.29
CK4-4-60	CK4	39	22	22	60	M080Z120-30P-D	L04	0.47
CK5-5-60	CK5	50	28	28	60	M100Z160-30P-D	L05	0.75
CK5-5-90	CK5	50	28	28	90	M100Z160-30P-D	L05	1.18
CK6-6-60	CK6	64	36	36	60	M120Z200-30P-D	L06	1.46
CK6-6-100	CK6	64	36	36	100	M120Z200-30P-D	L06	2.35
CK7-7-105	CK7	80	36	36	105	M200Z300-30P-D	L10	5.28

CK

Unequal Diameter Extension Adapter

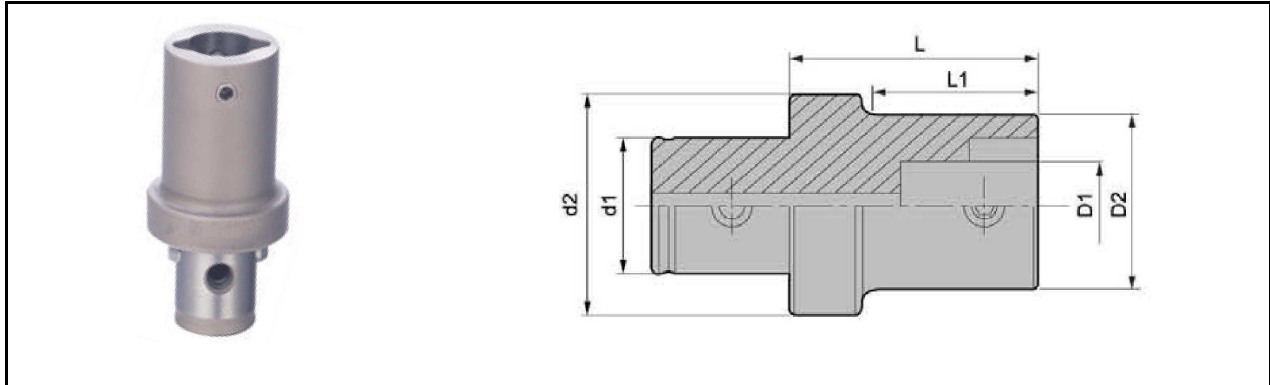

PRODUCT SERIES	DIMENSION						CKCK side screw	WRENC H	Kg
	D1	D2	d1	d2	L1	L			
CK2-1-36	11	19	14	24	30	36	M050Z050-30P-D	L025	0.08
CK3-1-41	11	19	18	31	30	41	M050Z050-30P-D	L025	0.12
CK3-2-37	14	24	18	31	25	37	M050Z060-30P-D	L025	0.13
CK4-1-58	11	19	22	39	40	58	M050Z050-30P-D	L025	0.24
CK4-2-50	14	24	22	39	36	50	M050Z060-30P-D	L025	0.22
CK4-3-50	18	31	22	39	37	50	M060Z090-30P-D	L03	0.30
CK5-1-60	11	19	28	50	40	60	M050Z050-30P-D	L025	0.38
CK5-2-54	14	24	28	50	35	54	M050Z060-30P-D	L025	0.38
CK5-2-74	14	24	28	50	55	74	M050Z060-30P-D	L025	0.45
CK5-3-47	18	31	28	50	29	47	M060Z090-30P-D	L03	0.46
CK5-3-72	18	31	28	50	54	72	M060Z120-30P-D	L03	0.54
CK5-4-42	22	39	28	50	25	42	M080Z120-30P-D	L04	0.43
CK5-4-67	22	39	28	50	50	67	M080Z050-30P-D	L04	0.62
CK6-1-70	11	19	36	64	40	70	M050Z060-30P-D	L025	0.90
CK6-2-63	14	24	36	64	45	63	M050Z060-30P-D	L025	0.66
CK6-2-93	14	24	36	64	75	93	M050Z090-30P-D	L025	0.71
CK6-3-56	18	31	36	64	39	56	M060Z090-30P-D	L03	0.70
CK6-3-96	18	31	36	64	79	96	M060Z120-30P-D	L03	0.91
CK6-4-51	22	39	36	64	35	51	M080Z120-30P-D	L04	0.76
CK6-4-101	22	39	36	64	85	101	M080Z160-30P-D	L04	1.19
CK6-5-41	28	50	36	64	25	41	M100Z160-30P-D	L05	0.72
CK6-5-91	28	50	36	64	75	91	M100Z050-30P-D	L05	1.46
CK7-6-106	28	50	36	64	75	91	M100Z050-30P-D	L05	3.12

CT

Bridge boring tool holder

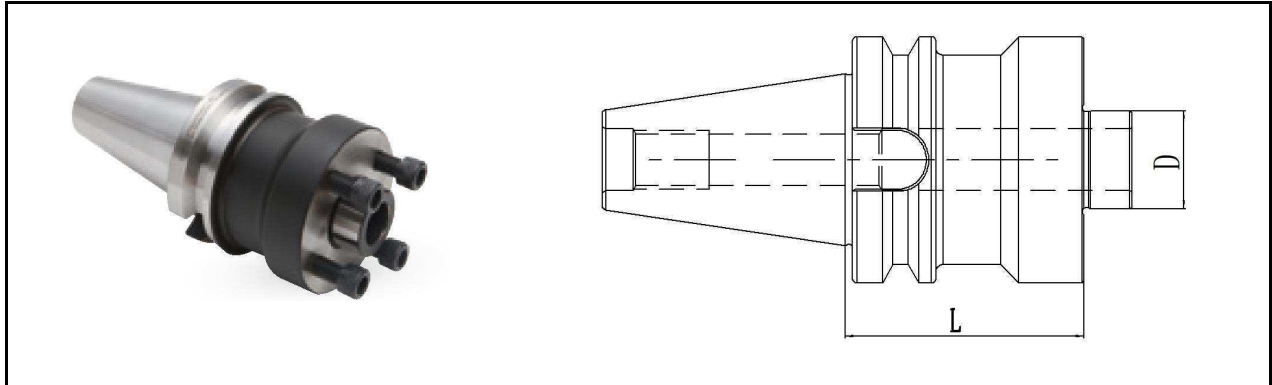

PRODUCT SERIES	ΦD	L	Fastening screws	handle type	weight kg
BT40-CT-100	40	100	E120U400-D	BT40	2.90
BT40-CT-150	40	150	E120U400-D		4.24
BT50-CT-100	40	100	E120U400-D	BT50	5.50
BT50-CT-150	40	150	E120U400-D		6.38
BT50-CT-200	40	200	E120U400-D		7.61
BT50-CT-250	40	250	E120U400-D		10.44
BT50-CT-300	40	300	E120U400-D		12.37
BT50-CT-350	40	350	E120U400-D		14.33
BT50-CT-400	40	400	E120U400-D		15.0
SK50-CT-100	40	100	E120U400-D	SK50	5.50
SK50-CT-150	40	150	E120U400-D		6.38
SK50-CT-200	40	200	E120U400-D		7.61
HSKA100-CT-100	40	100	E120U400-D	HSKA100	3.96
HSKA100-CT-150	40	150	E120U400-D		4.59
HSKA100-CT-200	40	200	E120U400-D		5.48
HSKA100-CT-250	40	250	E120U400-D		7.52
HSKA100-CT-300	40	300	E120U400-D		10.32

HSK-CP



Inner cooling tube

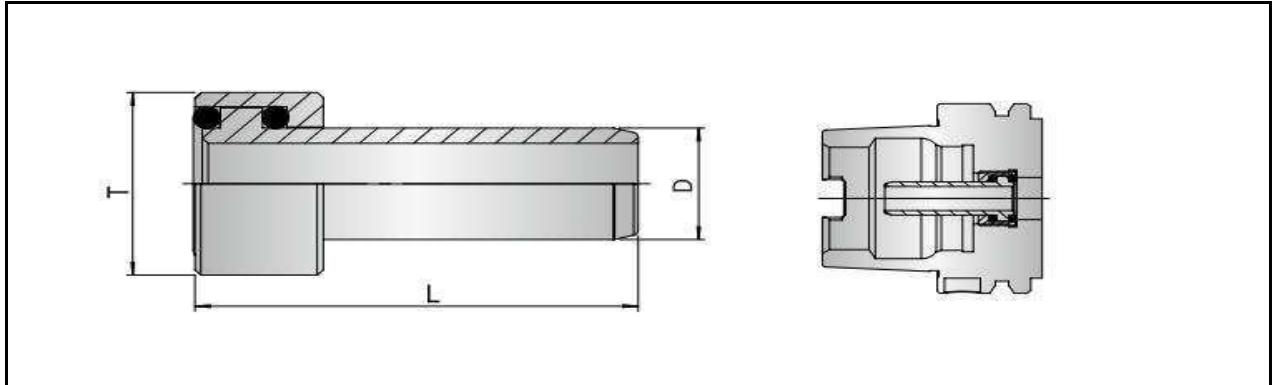

PRODUCT SERIES	L	11	D	T	weight kg
HSK63-CP	36.6	11.5	12	M18x1.0	0.02
HSK100-CP	44	15.5	16	M24x1.0	0.06

Inner cooling tube special WRENCH

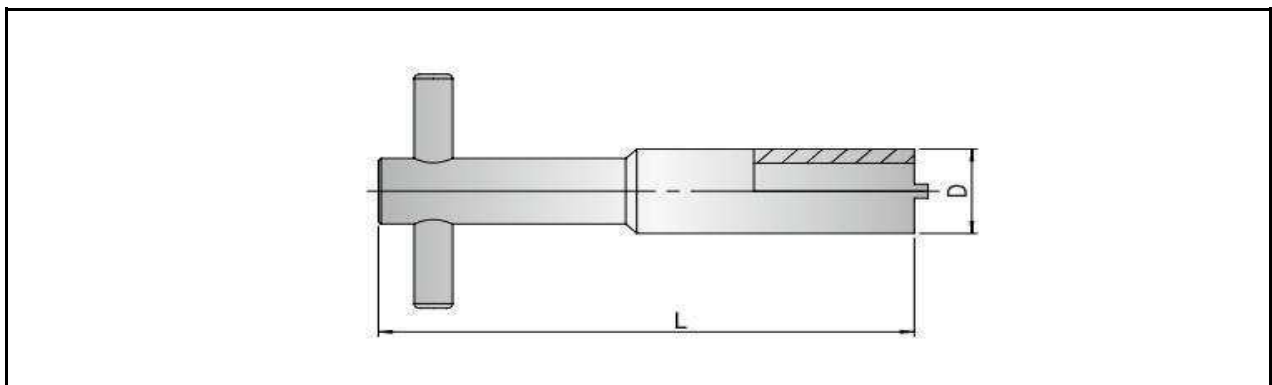

PRODUCT SERIES	L	D	weight kg
HSK63-CPW	100	18	0.14
HSK100-CPW	125	24	0.32

